

Viking

USE AND CARE MANUAL



Built-In Convection Microwave Hoods

SERVICE INFORMATION

If service is required:

1. Call your dealer or authorized service agency. The name of the authorized service agency can be obtained from the dealer or distributor in your area.
2. Have the following information readily available:
 - a. Model number
 - b. Serial number
 - c. Date purchased
 - d. Name of dealer from whom purchased
3. Clearly describe the problem that you are having.

If you are unable to obtain the name of an authorized service agency, or if you continue to have a service problem, contact Viking Range Corporation at (888) 845-4641 or write to:

VIKING RANGE CORPORATION
PREFERRED SERVICE
111 Front Street
Greenwood, Mississippi (MS) 38930 USA

Record the information indicated below. You will need it if service is ever required. The model and serial number for your microwave oven are located on the left side of the microwave oven cavity on an identification label.

Model Number _____ Serial Number _____

Date of Purchase _____ Date Installed _____

Dealer's Name _____

Address _____

If service requires installation of parts, use only authorized parts to ensure protection under the warranty.

PLEASE RETAIN THIS MANUAL FOR FUTURE REFERENCE

TABLE OF CONTENTS

2 SERVICE INFORMATION	28 Preheat and Cook with Convection
3 TABLE OF CONTENTS	28-29 Broil
4-5 IMPORTANT SAFETY INSTRUCTIONS	29 Slow Cook
5 PRECAUTIONS TO AVOID POSSIBLE EXPOSURE TO EXCESSIVE MICROWAVE ENERGY	29-30 Automatic Mix Cooking
6 UNPACKING AND EXAMINING YOUR MICROWAVE OVEN	29-30 Low Mix/Bake
7 GROUNDING INSTRUCTIONS	29 High Mix/Roast
8-14 INFORMATION YOU NEED TO KNOW	30 Cook with Automatic Mix
8 About Your Microwave Oven	30 Preheat and Cook with Automatic Mix
8-9 About Children and the Microwave	30-34 CONVECTION AUTOMATIC OPERATION
9 About Food	30-31 Convec Broil
10-12 About Utensils and Coverings	31 Convec Broil Chart
13 About Microwave Cooking	32 Convec Roast
14 About Safety	32 Convec Roast Chart
15-17 PART NAMES	33 Convec Bake
15-16 Microwave Oven Parts	33-34 Convec Bake Chart
16 Accessories	35-37 OTHER CONVENIENT FEATURES
17 Control Panel	35-36 Help (Control pad)
18 BEFORE OPERATING	36 Multiple Sequence Cooking
18 To Set the Clock	36 Timer
18 Stop/Clear	37 More or Less Time Adjustment
19-21 MANUAL MICROWAVE OPERATION	37 Add-A-Minute
19 Time cooking microwave	37 Touch On
19 To set power level	37 Help (Display indicator)
20 Keep Warm	38 Demonstration Mode
20 Hood Light/Hood Fan	38-41 CLEANING AND CARE
20-21 Turntable On/Off	38 Exterior
21-27 MICROWAVE FEATURES	38 Door
21 Defrost	38 Touch Control Panel
22 Defrost Chart	38 Interior - After microwave cooking
22 Manual Defrost	39 Interior - After convection, mix or broil cooking
23-24 Sensor Cooking	39 Waveguide Cover
24 Reheat	39 Odor Removal
24 Popcorn	39 Turntable/Turntable Support
25 Sensor Chart	39 Microwave Oven Racks
26 Sensor Cook	39-40 Grease Filters
26-27 Sensor Cook Chart	40 Fan
27-30 MANUAL CONVECTION AND AUTOMATIC MIX COOKING	40 Light
27-28 Convection Cooking	41 Charcoal Filter
27-28 Cook with Convection	41 Microwave Oven Light
	42 SPECIFICATIONS
	43 SERVICE CALL CHECK
	44 MICROWAVE OVEN WARRANTY

IMPORTANT SAFETY INSTRUCTIONS

When using electrical appliances basic safety precautions should be followed, including the following:

WARNING - To reduce the risk of burns, electric shock, fire, injury to persons or exposure to excessive microwave energy:

1. READ ALL INSTRUCTIONS BEFORE USING THE APPLIANCE.
2. Read and follow the specific "PRECAUTIONS TO AVOID POSSIBLE EXPOSURE TO EXCESSIVE MICROWAVE ENERGY" on page 5.
3. This appliance must be grounded. Connect only to properly grounded outlet. See "GROUNDING INSTRUCTIONS" on page 7.
4. Install or locate this appliance only in accordance with the provided installation instructions.
5. Some products such as whole eggs and sealed containers—for example, closed glass jars—are able to explode and should not be heated in this microwave oven.
6. Use this appliance only for its intended use as described in this manual. Do not use corrosive chemicals or vapors in this appliance. This type of microwave oven is specifically designed to heat, cook or dry food. It is not designed for industrial or laboratory use.
7. As with any appliance, close supervision is necessary when used by children.
8. Do not operate this appliance if it has a damaged cord or plug, if it is not working properly or if it has been damaged or dropped.
9. This appliance should be serviced only by qualified service personnel. Contact nearest Viking Authorized Servicer for examination, repair or adjustment.
10. Do not cover or block any openings on the appliance.
11. Do not store or use this appliance outdoors. Do not use this product near water—for example, near a kitchen sink, in a wet basement or near a swimming pool, or similar locations.
12. Do not immerse cord or plug in water.
13. Keep cord away from heated surfaces.
14. Do not let cord hang over edge of table or counter.
15. See door surface cleaning instructions on page 38.
16. To reduce the risk of fire in the microwave oven cavity:
 - a. Do not overcook food. Carefully attend appliance when paper, plastic or other combustible materials are placed inside the microwave oven to facilitate cooking.
 - b. Remove wire twist-ties from paper or plastic bags before placing bag in microwave oven.
 - c. **If materials inside the microwave oven should ignite, keep microwave oven door closed, turn microwave oven off and disconnect the power cord or shut off power at the fuse or circuit breaker panel.**
 - d. Do not use the cavity for storage purposes. Do not leave paper products, cooking utensils or food in the cavity when not in use.

17. Liquids, such as water, coffee or tea are able to be overheated beyond the boiling point without appearing to be boiling. Visible bubbling or boiling when the container is removed from the microwave oven is not always present. THIS COULD RESULT IN VERY HOT LIQUIDS SUDDENLY BOILING OVER WHEN A SPOON OR OTHER UTENSIL IS INSERTED INTO THE LIQUID.
To reduce the risk of injury to persons:
 - a. Do not overheat the liquid.
 - b. Stir the liquid both before and halfway through heating it.
 - c. Do not use straight-sided containers with narrow necks. Use a wide-mouthed container.
 - d. After heating, allow the container to stand in the microwave oven at least for 20 seconds before removing the container.
 - e. Use extreme care when inserting a spoon or other utensil into the container.
18. Clean ventilation openings and grease filters frequently—Grease should not be allowed to accumulate on ventilation openings, hood (louver) or grease filters.
19. Use care when cleaning the louver and the grease filters. Corrosive cleaning agents, such as lye-based oven cleaners, may damage the louver and the grease filters.
20. When flaming food under the hood, turn the fan on.
21. This appliance is suitable for use above both gas and electric cooking equipment 36" wide or less.

SAVE THESE INSTRUCTIONS

PRECAUTIONS TO AVOID POSSIBLE EXPOSURE TO EXCESSIVE MICROWAVE ENERGY

- (a) Do not attempt to operate this microwave oven with the door open since open-door operation can result in harmful exposure to microwave energy. It is important not to defeat or tamper with the safety interlocks.
- (b) Do not place any object between the microwave oven front face and the door or allow soil or cleaner residue to accumulate on sealing surfaces.
- (c) Do not operate the microwave oven if it is damaged. It is particularly important that the microwave oven door close properly and that there is no damage to the: (1) door (bent), (2) hinges and latches (broken or loosened), (3) door seals and sealing surfaces.
- (d) The microwave oven should not be adjusted or repaired by anyone except properly qualified service personnel.

UNPACKING AND EXAMINING YOUR MICROWAVE OVEN

Remove all packing materials from inside the microwave oven cavity; however, **DO NOT REMOVE THE WAVEGUIDE COVER**, which is located on the top cavity wall. Read enclosures and **SAVE** the Use and Care Manual.

Remove the feature sticker from the outside of the door, if there is one.

Check the microwave oven for any damage, such as misaligned or bent door, damaged door seals and sealing surfaces, broken or loose door hinges and latches and dents inside the cavity or on the door. If there is any damage, do not operate the microwave oven and contact your dealer or **VIKING AUTHORIZED SERVICER**.

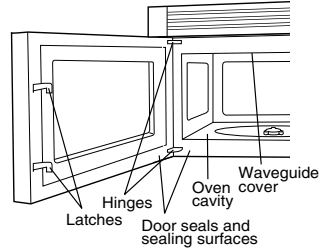

GROUNDING INSTRUCTIONS

This appliance must be grounded. This microwave oven is equipped with a cord having a grounding wire with a grounding plug. It must be plugged into a wall receptacle that is properly installed and grounded in accordance with the National Electrical Code and local codes and ordinances. In the event of an electrical short circuit, grounding reduces risk of electric shock by providing an escape wire for the electric current.

WARNING – Improper use of the grounding plug can result in a risk of electric shock.

ELECTRICAL REQUIREMENTS

Check Installation Instructions for proper location for the power supply.

The electrical requirements are a 120 volt 60 Hz, AC only, 15 amp. or more protected electrical supply. It is recommended that a separate circuit serving only this appliance be provided.

The microwave oven is equipped with a 3-prong grounding plug. It must be plugged into a wall receptacle that is properly installed and grounded. **DO NOT UNDER ANY CIRCUMSTANCES CUT OR REMOVE THE GROUNDING PIN FROM THE PLUG.**

Note:

1. If you have any questions about the grounding or electrical instructions, consult a qualified electrician or service person.
2. Neither Viking nor the dealer can accept any liability for damage to the microwave oven or personal injury resulting from failure to observe the correct electrical connection procedures.

RADIO OR TV INTERFERENCE

Should there be any interference caused by the microwave oven to your radio or TV, check that the microwave oven is on a different electrical circuit, relocate the radio or TV as far away from the microwave oven as feasible or check the position and signal of the receiving antenna.

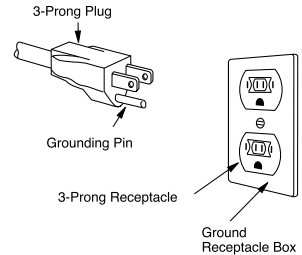

INFORMATION YOU NEED TO KNOW

ABOUT YOUR MICROWAVE OVEN

This Use and Care Manual is valuable: read it carefully and always save it for reference.

A good microwave cookbook is a valuable asset. Check it for microwave cooking principles, techniques, hints and recipes.

NEVER use the microwave oven without the turntable and support nor turn the turntable over so that a large dish could be placed in the microwave oven. The turntable will turn both clockwise and counterclockwise.

ALWAYS have food in the microwave oven when it is on to absorb the microwave energy.

When using the oven at power levels below 100%, you may hear the magnetron cycling on and off.

Condensation is a normal part of microwave cooking. Room humidity and the moisture in food will influence the amount of moisture that condenses in the microwave oven. Generally, covered foods will not cause as much condensation as uncovered ones. Vents on the microwave oven back must not be blocked.

After using convection, automatic mix or broil, you will hear the sound of the cooling fan. The fan may continue to operate as long as 5 minutes, depending on the oven temperature.

Be aware that, unlike microwave-only ovens, convection microwave ovens have a tendency to become hot during convection, automatic mix and broil cooking.

The microwave oven is for food preparation only. It should not be used to dry clothes or newspapers.

Your microwave output is rated 850 watts using the IEC Test Procedure. In using recipes or package directions, check food at the minimum time and add time accordingly.

ABOUT CHILDREN AND THE MICROWAVE

Children below the age of 7 should use the microwave oven with a supervising person very near to them. Between the ages of 7 and 12, the supervising person should be in the same room.

The child must be able to reach the microwave oven comfortably; if not, he/she should stand on a sturdy stool.

At no time should anyone be allowed to lean or swing on the microwave oven door.

Children should be taught all safety precautions: use potholders, remove coverings carefully, pay special attention to packages that crisp food because they may be extra hot.

Don't assume that because a child has mastered one cooking skill, he/she can cook everything.

Children need to learn that the microwave oven is not a toy. See page 35 for Child Lock feature.

ABOUT FOOD

FOOD	DO	DON'T
Eggs, sausages, nuts, seeds, fruits & vegetables	<ul style="list-style-type: none">• Puncture egg yolks before cooking to prevent "explosion".• Pierce skins of potatoes, apples, squash, hot dogs and sausages so that steam escapes.	<ul style="list-style-type: none">• Cook eggs in shells.• Reheat whole eggs.• Dry nuts or seeds in shells.
Popcorn (See page 24 for specific cooking instructions)	<ul style="list-style-type: none">• Use specially bagged popcorn for the microwave oven.• Listen while popping corn for the popping to slow to 1 or 2 seconds or use special Popcorn pad.	<ul style="list-style-type: none">• Pop popcorn in regular brown bags or glass bowls.• Exceed maximum time on popcorn package.
Baby food	<ul style="list-style-type: none">• Transfer baby food to small dish and heat carefully, stirring often. Check temperature before serving.• Put nipples on bottles after heating and shake thoroughly. "Wrist" test before feeding.	<ul style="list-style-type: none">• Heat disposable bottles.• Heat bottles with nipples on.• Heat baby food in original jars.
General	<ul style="list-style-type: none">• Cut baked goods with filling after heating to release steam and avoid burns.• Stir liquids briskly before, during and after heating to avoid "eruption".• Use deep bowl, when cooking liquids or cereals, to prevent boilovers.	<ul style="list-style-type: none">• Heat or cook in closed glass jars or air tight containers.• Can in the microwave as harmful bacteria may not be destroyed.• Deep fat fry.• Dry wood, gourds, herbs or wet papers.

ABOUT UTENSILS AND COVERINGS

It is not necessary to buy all new cookware. Many pieces, already in your kitchen, can be used successfully in your new convection microwave oven. The chart below will help you decide what utensils and coverings should be used in each mode.

UTENSILS AND COVERINGS	MICROWAVE ONLY	CONVEC BROIL, SLOW COOK	HIGH MIX/ ROAST LOW MIX/BAKE
Aluminum foil	YES. Small flat pieces of aluminum foil placed smoothly on food can be used to shield areas from cooking or defrosting too quickly. Keep foil at least 1 inch from walls of oven.	YES. For shielding	YES. For shielding
Aluminum containers	YES. Can be used if 3/4 filled with food. Keep 1 inch away from walls and do not cover with foil.	YES. Broil- No cover	YES. Can be used if 3/4 filled with food. Keep 1 inch away from walls and do not cover with foil.
Browning dish	YES. Do not exceed recommended preheating time. Follow manufacturer's directions.	NO	NO
Glass ceramic (Pyroceram®)	YES. Excellent	YES. Excellent	YES. Excellent
Glass, heat-resistant	YES. Excellent.	YES. Excellent.	YES. Excellent.
Glass, non-heat-resistant	NO	NO	NO
Lids, glass	YES	YES. Broil- No cover	YES

UTENSILS AND COVERINGS	MICROWAVE ONLY	CONVECTION BROIL, SLOW COOK	HIGH MIX/ ROAST LOW MIX/BAKE
Lids, metal	NO	YES. Broil- No cover	NO
Metal cookware	NO	YES	YES. Do not use metal covering.
Metal, misc: dishes with metallic trim, screws, bands, handles. Metal twist ties	NO	NO	NO
Oven cooking bags	YES. Good for large meats or foods that need tenderizing. DO NOT use metal twist ties.	YES. Broil- No cover	YES. DO NOT use metal twist ties.
Paper plates	YES. For reheating.	NO	NO
Paper towels	YES. To cover for reheating and cooking. Do not use recycled paper towels which may contain metal fillings.	NO	NO
Paper, ovenable	YES	YES. For temperatures up to 400°F. Do not use for broiling.	YES. For temperatures up to 400°F.
Microwave-safe plastic containers	YES. Use for reheating and defrosting. Some microwave-safe plastics are not suitable for cooking foods with high fat and sugar content. Follow manufacturer's directions.	NO	NO

UTENSILS AND COVERINGS	MICROWAVE ONLY	CONVECTION BROIL, SLOW COOK	HIGH MIX/ROAST LOW MIX/BAKE
Plastic, Thermoset®	YES	YES. Are heat resistant up to 425°F. Do not use for broiling.	YES
Plastic wrap	YES. Use brands specially marked for microwave use. DO NOT allow plastic wrap to touch food. Vent so steam can escape.	NO	NO
Pottery, porcelain stoneware	YES. Check manufacturer's recommendation for being microwave safe.	YES	YES. Must be microwave safe AND ovenable.
Styrofoam	YES. For reheating.	NO	NO
Wax paper	YES. Good covering for cooking and reheating.	NO	NO
Wicker, wood, straw	YES. May be used for short periods of time. Do not use with high fat or high sugar content foods. Could char.	NO	NO

DISH CHECK If you wish to check if a dish is safe for microwaving, place the empty dish in the oven and microwave on HIGH for 30 seconds. If the dish becomes very hot, do NOT use it for microwaving.

ACCESSORIES There are many microwave accessories available for purchase. Evaluate carefully before you purchase, so that they meet your needs. A microwave-safe thermometer will assist you in determining correct doneness and assure you that foods have been cooked to safe temperatures when using microwave-only cooking. Viking is not responsible for any damage to the microwave oven when accessories are used.

ABOUT MICROWAVE COOKING

- Arrange food carefully. Place thickest areas towards outside of dish.
- Watch cooking time. Cook for the shortest amount of time indicated and add more as needed. Food severely overcooked can smoke or ignite.
- Cover foods while cooking. Check recipe or cookbook for suggestions: paper towels, wax paper, microwave plastic wrap or a lid. Covers prevent spattering and help foods to cook evenly.
- Shield any thin areas of meat or poultry with small flat pieces of aluminum foil to prevent overcooking before dense, thick areas are cooked thoroughly.
- Stir foods from outside to center of dish once or twice during cooking, if possible.
- Turn foods over once during microwaving to speed cooking of such foods, as chicken and hamburgers. Large items like roasts must be turned over at least once.
- Rearrange foods such as meatballs halfway through cooking both from top to bottom and from the center of the dish to the outside.
- Add standing time. Remove food from microwave oven and stir, if possible. Cover for standing time which allows the food to finish cooking without overcooking.
- Check for doneness. Look for signs indicating that cooking temperatures have been reached.

Doneness signs include:

- Food steams throughout, not just at edge.
- Center bottom of dish is very hot to the touch.
- Poultry thigh joints move easily.
- Meat and poultry show no pinkness.
- Fish is opaque and flakes easily with a fork.

ABOUT SAFETY

- Check foods to see that they are cooked to the United States Department of Agriculture's recommended temperatures.

To test for doneness, insert a meat thermometer in a thick or dense area away from fat or bone. NEVER leave the thermometer in the food during cooking, unless it is approved for microwave oven use.

TEMP	FOOD
160°F (71°C)	For fresh pork, ground meat, boneless white poultry, fish, seafood, egg dishes and frozen prepared food.
165°F (74°C)	For leftover, ready-to-reheat refrigerated, and deli and carry-out "fresh" food.
170°F (77°C)	White meat of poultry.
180°F (82°C)	Dark meat of poultry.

- ALWAYS use potholders to prevent burns when handling utensils that are in contact with hot food. Enough heat from the food can transfer through utensils to cause skin burns.
- Avoid steam burns by directing steam away from the face and hands. Slowly lift the farthest edge of a dish's covering and carefully open popcorn and microwave oven cooking bags away from the face.
- Stay near the microwave oven while it's in use and check cooking progress frequently so that there is no chance of overcooking food.
- NEVER use the cavity for storing cookbooks or other items.
- Select, store and handle food carefully to preserve its high quality and minimize the spread of foodborne bacteria.
- Keep waveguide cover clean. Food residue can cause arcing and/or fires.
- Use care when removing items from the microwave oven so that the utensil, your clothes or accessories do not touch the safety door latches.
- Keep aluminum foil used for shielding at least 1 inch away from walls, ceiling and door of microwave oven.

PART NAMES

MICROWAVE OVEN PARTS

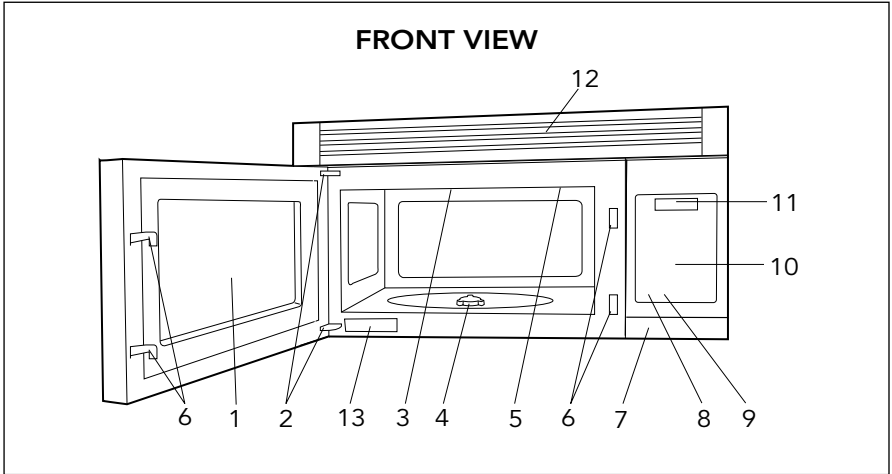

1. Oven door with see-through window.
2. Door hinges.
3. Waveguide cover
DO NOT REMOVE.
4. Turntable motor shaft.
5. Oven light.
It will light when oven is operating or door is open.
6. Safety door latches.
The oven will not operate unless the door is securely closed.
7. One touch DOOR OPEN button.
Push to open door.
8. Fan Hi / Lo button.
Push for high/low/off.
9. Light button.
Push for on/off.
10. Auto-Touch control panel.
11. Time display: Digital display, 99 minutes 99 seconds.
12. Ventilation openings.
13. Serial plate

INTERACTIVE COOKING SYSTEM

The Interactive Cooking System offers step-by-step instructions in the display for using the oven, from setting the clock to programming each feature. It also includes Help setting for instructions on using Child Lock, Audible Signal Elimination, Auto Start and Help. There is a choice of English, Spanish or French and a choice of U.S. Customary Unit-pound or Metric-kilograms. Touch Help and follow the directions displayed or check page 35-36.

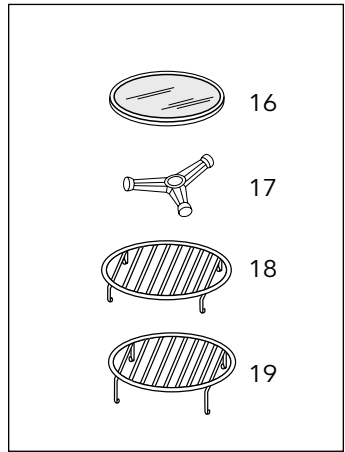
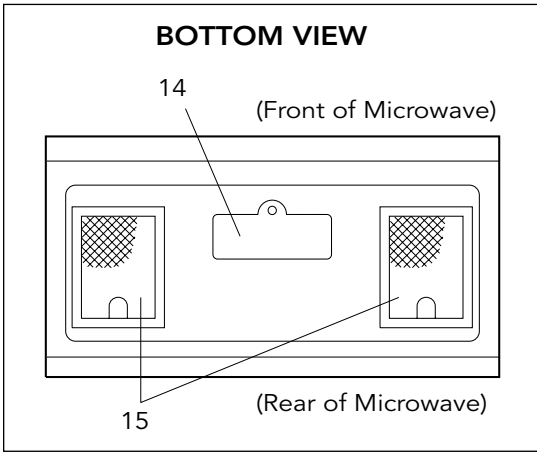

- 14. Light cover.
- 15. Grease filters.
- 16. Removable ceramic turntable.
The turntable will rotate clockwise or counterclockwise. Only remove for cleaning.

- 17. Removable turntable support.
Place the turntable support on the floor of the oven cavity and the turntable on the turntable support.
- 18. Removable low rack for broiling and meat and poultry roasting.
- 19. Removable high rack for two level baking.

ACCESSORIES

The following accessories are designed especially for use in this oven only for convection, mix or broil cooking. **DO NOT USE FOR MICROWAVE ONLY COOKING.** Do not substitute similar types of racks for these specially designed ones.

High rack (Baking rack)—for convection and low mix.

- This rack is placed on the turntable for two-level cooking, such as layer cakes, muffins, etc.

Low rack (Broiling rack)—for convection, broiling or high mix.

- Place on the turntable and use for roasting or broiling to allow juices to drain away from food.

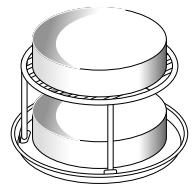

CONTROL PANEL

Interactive Display Words will light in the display to indicate features and cooking instructions.

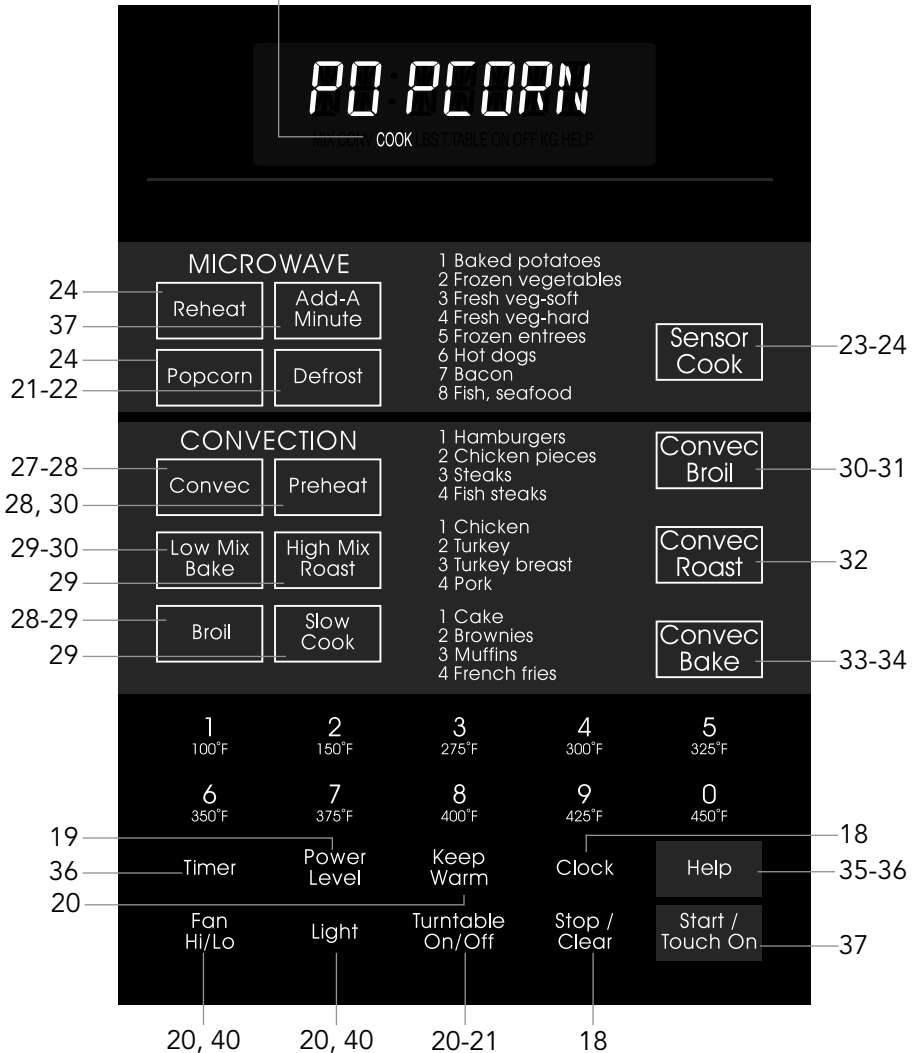

Number next to the control panel illustration indicates pages on which there are feature descriptions and usage information.

BEFORE OPERATING

- Before operating your new microwave oven make sure you read and understand this Use and Care Manual completely.
- Before the microwave oven can be used, follow these procedures:
 1. Plug in the microwave oven. Close the door. The microwave oven display will show WELCOME.
 2. Touch the Stop/Clear pad. : will appear.
 3. Set clock.

TO SET THE CLOCK

1. Touch Clock pad.
2. Enter the correct time of day by touching the numbers in sequence. Touch Clock pad again.

This is a 12 hour clock. If you attempt to enter an incorrect clock time, ERROR will appear in the display. Touch the Stop/Clear pad and re-enter the time.

- If the electrical power supply to your microwave oven should be interrupted, the display will intermittently show WELCOME after the power is reinstated. If this occurs during cooking, the program will be erased. The time of day will also be erased. Simply touch Stop/Clear pad and reset the clock for the correct time of day.

Note: Your oven can be programmed with the door open except for Start/Touch On, Add-A-Minute, Reheat and Popcorn.

STOP/CLEAR

Touch the Stop/Clear pad to:

1. Erase if you make a mistake during programming.
2. Cancel timer.
3. Stop the microwave oven temporarily during cooking.
4. Return the time of day to the display.
5. Cancel a program during cooking, touch twice.

MANUAL MICROWAVE OPERATION

TIME COOKING MICROWAVE

Your microwave oven can be programmed for 99 minutes 99 seconds (99.99). Always enter the seconds after the minutes, even if they are both zeros.

- Suppose you want to cook for 5 minutes at 100%
1. Enter cooking time by touching the number pads **5****0****0**.
 2. Touch Start/Touch On pad.

TO SET POWER LEVEL

There are eleven preset power levels.

Using lower power levels increases the cooking time which is recommended for foods such as cheese, milk and long slow cooking of meats. Consult cookbook or recipes for specific recommendations.

TOUCH POWER LEVEL PAD ONCE THEN TOUCH	APPROXIMATE PERCENTAGE OF POWER	COMMON WORDS FOR POWER LEVELS
Power Level	100%	High
9	90%	
8	80%	
7	70%	Medium High
6	60%	
5	50%	Medium
4	40%	
3	30%	Med Low/Defrost
2	20%	
1	10%	Low
0	0%	

- Suppose you want to defrost for 5 minutes at 30%.
1. Enter defrosting time by touching the number pads **5****0****0**.
 2. Touch Power Level pad and number **3**.
 3. Touch Start/Touch On pad.

KEEP WARM

Keep Warm can only be programmed with manual cooking or as a separate program.

- Suppose you want to cook a baked potato for 4 minutes at 100% power and you want to keep it warm after cooking for 30 minutes.
1. Touch number pads for the desired cook time for 1 baked potato. Ex: **4|0|0** for 4 minutes.
 2. Touch Keep Warm pad.
 3. Touch Start/Touch On pad.

At the end of cook time, Keep Warm is displayed warming food until end of 30 minutes.

To use Keep Warm as a separate program, touch Keep Warm pad within 1 minute after cooking, closing the door or touching the Stop/Clear pad.

HOOD LIGHT/HOOD FAN

Your microwave oven is equipped with a Hood Light and a Hood Fan which can be used whether the door is open or closed.

To turn the Hood Light on, touch the Light pad once. To turn the Hood Light off, touch the Light pad again.

To turn the Hood Fan on, touch the Fan Hi/Lo pad once for high speed. To turn the Hood Fan to low speed, touch pad twice and touch the pad three times to turn the fan off.

TURNTABLE ON/OFF

For most cooking, the turntable should be on; however the turntable can be turned off so that it does not rotate when extra large dishes, such as the popular 13"x9"x2" glass utility casserole, are used. The casserole should be placed on the turntable so that it is level.

- Suppose you want to cook lasagna in a 13"x9"x2" casserole for 45 minutes on 40% power.
1. Touch Turntable On/Off pad and note TURNTABLE OFF in the display.
 2. Enter cooking time by touching the number pads **4|5|0|0**.
 3. Touch Power Level pad and number **4** for 40% power.
 4. Touch Start/Touch On pad.

Note: The door can be opened for checking food and the turntable will stay in the off position. After checking, close door and touch Start/Touch On.

The turntable will stay off for one minute after door is opened when time-of-day appears in the display. It is possible to reprogram the oven during that minute without touching the Turntable On/Off pad. The display always indicates whether the turntable is off or on.

THE TURNTABLE SHOULD ALWAYS BE ON WHEN USING THE SPECIAL FEATURES. On/Off function can be used with manual cooking modes and Reheat. Turntable off condition will automatically change to on condition when you select auto cooking except Reheat and Convec Bake.

When cooking large quantities of food which cannot be stirred, it is best to use a lower power level such as 40% or 50%. You may speed cooking of large amounts by programming 5 to 10 minutes on 100% power (HIGH) followed by the desired time on lower power. See page 36 for how to program multiple sequences. You may wish to reverse a large casserole once during cooking; simply open door, reposition casserole, close door and touch Start/Touch On.

MICROWAVE FEATURES

DEFROST

Defrost automatically defrosts foods ground meat, steaks, chicken pieces.

- Suppose you want to defrost a 2.0 pound steak.
 1. Touch Defrost pad once.
 2. Select desired food by touching Defrost pad until the display shows the food name. Ex: touch twice for steak.
 3. Enter weight by touching the number pads **2****0**.
 4. Touch Start/Touch On pad.

The oven will stop and directions will be displayed. Follow the indicated message.
 5. After the 1st stage, open the door. Turn steak over and shield any warm portions. Close the door. Touch Start/Touch On pad.
 6. After the 2nd stage, open the door. Shield any warm portions. Close the door. Touch Start/Touch On pad.
 7. After defrost cycle ends, cover and let stand as indicated in chart on page 22.

Note:

1. The weight can be entered in increments of 0.1 lb. If you attempt to enter more or less than the allowed amount ERROR WEIGHT TOO SMALL OR TOO LARGE will appear in the display.
2. Defrost can be programmed with More/Less Time Adjustment. See page 37.
3. To defrost other foods or foods above or below the weights allowed on Defrost Chart, use time and 30% power. See Manual Defrost on page 22.

DEFROST CHART

TOUCH DEFROST PAD*	FOOD	AMOUNT	PROCEDURE
Once	Ground Meat	0.5 - 3.0 lb	Remove any thawed pieces after each stage. Let stand, covered, 5–10 minutes.
Twice	Steaks (Chops, fish)	0.5 - 4.0 lb	After each stage of defrost cycle, rearrange and if there are warm or thawed portions, shield with small flat pieces of aluminum foil. Remove any meat or fish that is nearly defrosted. Let stand, covered, 10–20 minutes.
3 times	Chicken Pieces	0.5 - 3.0 lb	After each stage of defrost cycle, if there are warm or thawed portions, rearrange or remove. Let stand, covered, 10–20 minutes.

* Number of touched AFTER initial touch to access Defrost.

Note: Check foods when oven signals. After final stage, small sections may still be icy. Let stand to continue thawing. Do not defrost until all ice crystals are thawed.

Shielding prevents cooking from occurring before the center of the food is defrosted. Use small smooth strips of aluminum foil to cover edges and thinner sections of the food.

MANUAL DEFROST

If the food that you wish to defrost is not listed on the DEFROST CHART or is above or below the limits in the AMOUNT column on the DEFROST CHART, you need to defrost manually.

You can defrost any frozen food, either raw or previously cooked, by using Power Level 3. Follow the exact 3-step procedure found under Time Cooking Microwave on page 19. Estimate defrosting time and press 3 for 30% when you select the power level.

For either raw or previously cooked frozen food the rule of thumb is approximately 5 minutes per pound. For example, defrost 5 minutes for 1 pound of frozen spaghetti sauce.

Always stop the microwave oven periodically to remove or separate the portions that are defrosted. If food is not defrosted at the end of the estimated defrosting time, program the oven in 1 minute increments on Power Level 3 until totally defrosted.

When using plastic containers from the freezer, defrost only long enough to remove from the plastic in order to place in a microwave-safe dish.

SENSOR COOKING

The Sensor is a semi-conductor device that detects the vapor (moisture and humidity) emitted from food as it heats. The sensor adjusts the cooking times and power level for various foods and quantities.

It takes the guesswork out of microwave cooking.

USING SENSOR SETTINGS:

1. Room temperature should not exceed 95°F.
2. Be sure the exterior of the cooking container and the interior of the microwave oven are dry. Wipe off any moisture with a dry cloth or paper towel.
3. During the first part of sensor cooking, the food name will appear on the display. Do not open the microwave oven door or touch Stop/Clear during this part of the cooking cycle. The measurement of vapor will be interrupted. If this occurs, an error message will appear and sensor cooking will be interrupted. To continue cooking, touch the Stop/Clear pad and select cooking time and power. When the sensor detects the vapor emitted from the food, remainder of cooking time will appear on display. At this time, you may stir or season food, as desired.
4. Check food for temperature after cooking. If additional time is needed, continue to cook with variable power and time.
5. If the sensor does not detect vapor properly, ERROR will be displayed, and the microwave oven will turn off.
6. Each food has a cooking hint. Touch Help pad when the HELP indicator is lighted in the display.
7. At the end of any cycle, open the door or touch Stop/Clear pad. The time of day will reappear on the display.

SELECTING FOODS:

1. The sensor works with foods at normal storage temperature. For example, food for dinner plate reheat would be at refrigerator temperature and popcorn at room temperature.
2. More or less food than the quantity listed in the charts should be cooked by time and variable power.

COVERING FOODS:

Some foods work best when covered. Use the cover recommended in the chart for these foods.

1. Casserole lid
2. **Plastic wrap:** Use plastic wrap recommended for microwave cooking. Cover dish loosely; allow approximately 1/2 inch to remain uncovered to allow steam to escape. Plastic wrap should not touch food.

3. **Paper towel:** Use paper towels to absorb excess fat and moisture when cooking bacon and potatoes. Line the turntable when baking potatoes.
 4. **Wax paper:** Cover dish completely; fold excess wrap under dish to secure. If dish is wider than paper, overlap two pieces at least one inch to cover.
- Be careful when removing any covering to allow steam to escape away from you.

REHEAT

TURNTABLE ON:

You can reheat many foods by touching just one pad. You don't need to calculate reheating time or power level. To reheat food with turntable on, simply touch the Reheat pad.

- Suppose you want to heat prepared chili.

Touch Reheat pad.

When sensor detects the vapor emitted from the food, remainder of reheating time will appear. After cooking, follow the instructions on the display.

TURNTABLE OFF:

You may reheat using a 11"x8"x2" or 13"x9"x2" casserole with the turntable off. First touch Turntable On/Off and note indicator. Then touch Reheat. The display will indicate turntable off and microwave oven will start automatically. After cooking, follow the instructions on the display.

POPCORN

- Suppose you want to pop a 3.5 oz. bag of popcorn.

Touch Popcorn pad once.

This sensor setting works well with most brands of microwave popcorn. You may wish to try several and choose your favorite. Pop only one bag at a time. Unfold the bag and place in oven according to directions.

SENSOR CHART

FOOD	AMOUNT	PROCEDURE
Leftovers such as rice, potatoes, vegetables, casserole.	4 - 32 oz	Place in dish or casserole slightly larger than amount to reheated. Flatten, if possible. Cover with lid, plastic wrap or wax paper. Use covers such as plastic wrap or lids with larger quantities of more dense foods such as stews.
Soup	1 - 4 cups	After reheating, stir well, if possible. Foods should be very hot. If not, continue to heat with variable power and time. After stirring, recover and allow to stand 2 to 3 minutes.
Canned entrees and vegetables	4 - 16 oz	Use Less Time Adjustment by touching Power Level pad twice for small quantities of canned vegetables.
Dinner Plate 1 plate	3 - 6 oz of meat plus vegetables and/or potato/ rice	Use this pad to reheat precooked foods from the refrigerator. Place meaty portions and bulky vegetables to outside of plate. Cut large items like baked potatoes in smaller pieces. Flatten foods such as mashed potatoes and other dense foods. Cover with wax paper or plastic wrap. ONE PLATE ONLY. After cooking, check that food is very hot throughout and that the bottom center of the plate is very hot. If not, continue heating using time and power level. Allow to stand, covered, 2 to 3 minutes.
Popcorn	Only 1 package at a time	Use only popcorn packaged for microwave oven use. Try several brands to decide which you like best. Do not try to pop unpoppered kernels. More/Less Time Adjustment can be used to provide adjustment needed for older popcorn or individual tastes.
	3.0 - 3.5 oz bag (Regular size)	Touch Popcorn pad once. This setting works well with most 3.0-3.5 oz bags of microwave popcorn.
	1.5 - 1.75 oz bag (Snack size)	Touch Popcorn pad twice for snack size bags.

SENSOR COOK

- Suppose you want to cook a baked potato.

1. Touch Sensor Cook pad.
2. Select desired sensor setting. Ex: touch number pad **1** to cook baked potatoes.
3. Touch Start/Touch On pad. When sensor detects the vapor emitted from the food, the remainder of cooking time will appear.

Open microwave oven door or touch Stop/Clear pad. The time of day will appear in the display.

SENSOR COOK CHART

FOOD	AMOUNT	PROCEDURE
1. Baked potatoes	1 - 6 medium	Pierce. Place on paper-towel-lined turntable. After cooking, remove from microwave oven, wrap in aluminum foil and let stand 5 to 10 minutes.
2. Frozen vegetables	1 - 6 cups	Cover with lid or plastic wrap. After cooking, stir and let stand 3 minutes, covered.
3. Fresh vegetables, soft		Wash and place in casserole. Add no water if vegetables have just been washed. Cover with lid for tender vegetables Use plastic wrap for tender-crisp vegetables. Stir before standing if possible. After cooking, let stand, covered, 2-5 minutes.
Broccoli	0.25 - 2.0 lb	
Brussels sprouts	0.25 - 2.0 lb	
Cabbage	0.25 - 2.0 lb	
Cauliflower (flowerets)	0.25 - 2.0 lb	
Cauliflower (whole)	1 medium	
Spinach	0.25 - 1.0 lb	
Zucchini	0.25 - 2.0 lb	
Baked apples	2 - 4 medium	
4. Fresh vegetables, hard		Place in casserole. Add 1-4 tbsp. water. Cover with lid for tender vegetables. Use plastic wrap cover for tender-crisp vegetables. Stir before standing, if possible. After cooking, let stand, covered, 2-5 minutes.
Carrots, sliced	0.25 - 1.5 lb	
Corn on cob	2 - 4 pcs.	
Green beans	0.25 - 1.5 lb	
Winter squash, diced	0.25 - 1.5 lb	
halves	1 - 2	

SENSOR COOK CHART (cont.)

FOOD	AMOUNT	PROCEDURE
5. Frozen entrees	6 - 17 oz	Use for frozen convenience food. It will give satisfactory results for most brands. You may wish to try several and choose your favorite. Remove package from outer wrapping and follow package directions for covering. After cooking, let stand, covered, for 1 to 3 minutes.
6. Hot dogs	1 - 4 servings	Place hot dog in bun and wrap in paper towel or paper napkin.
7. Bacon	2 - 6 slices	Place bacon on paper plate, lined with paper towel. Bacon should not extend over the rim of plate. Cover with paper towel.
8. Fish, seafood	0.25 - 2.0 lb	Arrange in ring around shallow glass dish (roll fillet with edges underneath). Cover with vented plastic wrap. After cooking, let stand, covered, 3 minutes.

MANUAL CONVECTION AND AUTOMATIC MIX COOKING

This section of the Use and Care Manual gives you specific cooking instructions and procedures. Please consult your Viking Convection Microwave Hood Cookbook for helpful hints for convection and combination cooking.

The microwave oven should not be used without the turntable in place, and it should never be restricted so that it cannot rotate. You may remove the turntable when preheating the microwave oven and when preparing food to be cooked directly on the turntable.

Caution: The microwave oven cabinet, cavity, door, turntable, turntable support, racks and dishes will become hot. To PREVENT BURNS, use thick oven gloves when removing the food or turntable from the microwave oven.

CONVECTION COOKING

During convection heating, hot air is circulated throughout the microwave oven cavity to brown and crisp foods quickly and evenly. This microwave oven can be programmed for ten different convection cooking temperatures for up to 99 minutes, 99 seconds.

COOK WITH CONVECTION

- Suppose you want to cook at 350°F for 20 minutes.
1. Touch Convec pad.
 2. Select temperature by touching number pad

6
350°F

.

3. Enter cooking time by touching number pads **2****0****0****0**.
4. Touch Start/Touch On pad.

PREHEAT AND COOK WITH CONVECTION

Your microwave oven can be programmed to combine preheating and convection cooking operations. You can preheat to the same temperature as the convection temperature or change to a higher or lower temperature.

- Suppose you want to preheat to 350°F, and then cook 25 minutes at 375°F convection:
 1. Touch Preheat pad.
 2. Select temperature by touching number pad **6**
350°F.
 3. Touch Convec pad.
 4. Select temperature by touching number pad **7**
375°F.
 5. Enter cooking time by touching number pads **2****5****0****0**.
 6. Touch Start/Touch On pad.

When the microwave oven reaches the programmed temperature, it will automatically hold at the preheat temperature for 30 minutes and then the display will change to time of day. Whenever Stop/Clear pad is touched during this 30 minute period, **PRESS CONVEC** or **PRESS MIX** will be displayed and cooking mode and time can be entered.

Note: To preheat and cook with the same temperature, enter same temperature in steps 2 and 4.

BROIL

Preheating is automatic when the Broil setting is used. Only actual cooking time is entered; the oven signals when it is preheated to 450°F. Oven temperature cannot be changed. Use Broil setting for steaks, chops, chicken pieces and many other foods. See Convection Broiling Chart in cookbook.

- Suppose you want to broil a ham steak for 15 minutes.
 1. Touch Broil pad.
 2. Enter cooking time by touching the number pads **1****5****0****0**.
 3. Touch Start/Touch On pad. No food in oven.

When the microwave oven reaches the programmed temperature, a signal will sound*.

4. Open the door. Place food in oven. Close the door. Touch Start/Touch On pad.

* If the microwave oven door is not opened, the microwave oven will automatically hold at the preheat temperature for 30 minutes. After this time has elapsed, an audible signal will sound and the microwave oven will turn off.

Note:

1. Preheating for broil may take from 7 to 10 minutes depending on temperature of room and available power.
2. Although time is usually set for the maximum broiling time, always check food at the minimum time recommended in the chart of cookbook. This will eliminate the need to completely reprogram the microwave oven if additional cooking time is needed. Simply close the microwave oven door and touch Start/Touch On to continue.

SLOW COOK

Slow Cook is preset at 300°F for 4 hours. The temperature can be changed to below 300°F. The cooking time cannot be changed. This feature can be used for foods such as baked beans or marinated chuck steak.

- Suppose you want to change oven temperature from 300°F to 275°F.
1. Touch Slow Cook pad.
 2. Touch Slow Cook pad once more if you want to change the temperature from 300°F.
 3. Touch temperature pad .
 4. Touch Start/Touch On pad.

Note: If you do not change the temperature, omit steps 2 and 3.

AUTOMATIC MIX COOKING

This microwave oven has two pre-programmed settings that make it easy to cook with both convection heat and microwave automatically.

	Microwave oven temperature	Microwave power
High Mix/Roast	325°F	30%
Low Mix/Bake	325°F	10%

With the exception of those foods that cook best by convection heating alone, most foods are well suited to mix cooking using either Low Mix/Bake or High Mix/Roast.

The marriage of these two cooking methods produces juicy meats, moist and tender cakes and fine textured breads, all with just the right amount of browning and crispness.

The temperatures can be changed; however, the microwave power cannot. The microwave oven temperature can be changed from 100°F to 450°F. To change the temperature, first touch High Mix or Low Mix then touch the same pad again. When the display says SELECT TEMP, touch desired temperature pad. Ex: High Mix, High Mix pad, . The mix temperature will change to 375°F automatically.

COOK WITH AUTOMATIC MIX

- Suppose you want to bake a cake for 25 minutes on Low Mix/Bake.
 1. Touch Low Mix/Bake pad.
 2. Enter cooking time by touching number pads **2****5****0****0**.
 3. Touch Start/Touch On pad.

PREHEAT AND COOK WITH AUTOMATIC MIX

Your microwave oven can be programmed to combine preheating and automatic mix cooking operations. You can preheat at the same temperature as the preset combination temperature or change it to a different temperature.

- Suppose you want to preheat to 350°F and then cook 25 minutes on 325°F Low Mix/Bake.
 1. Touch Preheat pad.
 2. Touch temperature pad **6**_{350°F}.
 3. Touch Low Mix pad.
 4. Enter cooking time by touching number pads **2****5****0****0**.
 5. Touch Start/Touch On pad.

When the microwave oven reaches the programmed temperature, signal will sound. The microwave oven will stop and directions will be displayed. Follow the indicated message.

6. Open the door. Place food in the microwave oven. Close the door. Touch Start/Touch On pad.

CONVECTION AUTOMATIC OPERATION

This section of the Use and Care manual offers instructions for preparing 12 popular foods using Convec Broil, Convec Roast and Convec Bake.

After selecting the desired feature, follow the directions indicated in the display.

For helpful hints, simply touch Help pad anytime HELP is lighted in the display.

CONVEC BROIL

Convec Broil automatically broils hamburgers, chicken pieces, steaks and fish steaks.

- Suppose you want to broil 2 hamburgers.
 1. Touch Convec Broil pad.
 2. Select desired setting. Ex: for hamburgers, touch number pad **1**.
 3. Touch number pad **2** for quantity and follow information in display for cooking information.

For well done or rare burgers, touch Power Level pad to select More for well done or Less for rare. See More/Less Time Adjustment on page 37.

4. Touch Start/Touch On pad.

After broil preheat cycle ends, 4 long tones will sound. PREHEAT OVER PLACE FOOD IN OVEN will be displayed repeatedly. Open the door and place hamburgers into microwave oven. Close the door.

5. Touch Start/Touch On pad.

After broil cycle ends, 1 long tone will sound and END will be displayed.

Note:

1. Convec Broil can be programmed with More/Less Time Adjustment. See page 37.
2. If you attempt to enter more or less than the allowed amount as indicated in chart below, an error message will appear in the display.
3. To broil other foods or foods above or below the weight or number allowed on Convec Broil Chart follow instructions in the Viking Convection Microwave Hood Cookbook. See Convection Broiling Chart.

CONVEC BROIL CHART

SETTING/FOOD	AMOUNT	PROCEDURE
1. Hamburgers	1 - 8 pcs 0.25 lb each	Use this setting to broil hamburger patties. Place on low rack.
2. Chicken pieces	0.5 - 3.0 lb	Arrange pieces on low rack. After cooking, let stand, 3-5 minutes. Dark meat should be 180°F, and white meat should be 170°F.
3. Steaks	0.5 - 2.0 lb	Use this setting to broil steaks from 3/4" to 1" thick. Individual boneless steaks broil evenly. Place steak on low rack. For well done, touch Power Level once; for rare, touch Power Level twice.
4. Fish steaks	0.5 - 2.0 lb	Use this setting to broil fish steak which is 3/4" to 1" thick. Place on low rack.

CONVEC ROAST

Convec Roast automatically roasts chicken, turkey, turkey breast or pork.

- Suppose you want to roast a 2.5 pound chicken.
 1. Touch Convec Roast pad.
 2. Select desired setting. Ex: for chicken, touch number pad **1**.
 3. Touch number pad to enter weight. Ex: **2****5** lb.
 4. Touch Start/Touch On pad.

After Convec Roast cycle ends, a long tone will sound. Follow the indicated message.

Note:

1. Convec Roast can be programmed with More/Less Time Adjustment. See page 37.
2. If you attempt to enter more or less than the allowed weight as indicated in chart below, an error message will appear in the display.
3. To roast other food or foods above or below the weights allowed on Convec Roast Chart, check the Viking Convection Microwave Hood Cookbook Combination Roasting Chart.

CONVEC ROAST CHART

SETTING/FOOD	AMOUNT	PROCEDURE
1. Chicken	2.5 - 7.0 lb	Place on low rack. After the cycle ends, cover with foil and let stand for 5-10 minutes.
2. Turkey	6.5 - 9.0 lb	Season, as desired. Place on low rack. After the cycle ends, cover with foil and let stand 10 minutes. Internal temperature of white meat should be 170°F and of dark meat, 180°F.
3. Turkey breast	3.0 - 6.0 lb	Season, as desired. Place on low rack. After the cycle ends, cover with foil and let stand 10 minutes. Internal temperature of white meat should be 170°F.
4. Pork	2.0 - 3.5 lb	Boneless pork loin is recommended because it cooks evenly. Place on a low rack. After cooking, remove from oven, cover with foil and allow to stand 5-10 minutes. Internal temperature should be 160°F.

CONVEC BAKE

Convec Bake automatically bakes cakes, brownies, muffins and French fries.

- Suppose you want to bake a 13"x9"x2" cake.

1. Touch Convec Bake pad.
2. Select desired setting. Ex: for cake, touch number pad **1**.
3. Touch Start/Touch On pad.

After Convec Bake preheat cycle ends, 4 long tones will sound. PREHEAT OVER PLACE FOOD IN OVEN will be displayed repeatedly. Open the door and place pan into microwave oven. Close the door.

4. Touch Start/Touch On pad.

After Convec Bake cycle ends, 1 long tone will sound and END will be displayed.

Note:

1. Convec Bake can be programmed with More/Less Time Adjustment. See page 37.
2. To bake other foods, see the Viking Convection Microwave Hood Cookbook's baking section.

CONVEC BAKE CHART

SETTING/ FOOD	PAN SIZE/ QTY	PROCEDURE
1. Cake	13"x9"x2"	Ideal for packaged cake mix or your own recipe. Prepare according to package or recipe directions and place in a greased and floured 13"x9"x2" pan. After the preheat is over, place pan in microwave oven centered on low rack. Cool before frosting and serving.
2. Brownies	13"x9"x2"	Ideal for packaged brownie mix or your own recipe for 13"x9"x2" pan. Prepare according to package or recipe directions and place in a greased and floured 13"x9"x2" baking pan. After the preheat is over, place pan in microwave oven centered on low rack. Cool before cutting into serving pieces.

3. Muffins	12 cup muffin pans	Ideal for packaged muffin mix or your own recipe for 12 medium size muffins. Prepare according to package or recipe directions and place in one 12-cup muffin pan. After the preheat is over, place pan in microwave oven centered on low rack.
4. French fries	3 - 24 oz Cookie sheet to hold	Use frozen prepared French fries. No preheat is required for the French fries baking procedure. Place French fries on cookie sheet on low rack. For shoestring potatoes, touch Power Level pad twice to enter less time before touching Start/Touch On pad.

OTHER CONVENIENT FEATURES

HELP (CONTROL PAD)

Help provides 5 features which make using your microwave oven easy because specific instructions are provided in the interactive display.

1. CHILD LOCK

The Child Lock prevents unwanted microwave oven operation such as by small children. The microwave oven can be set so that the control panel is deactivated or locked. To set, touch Help, the number **1** and Start/Touch On pads. Should a pad be touched, **LOCK** will appear in the display.

To cancel, touch Help and Stop/Clear pads.

2. AUDIBLE SIGNAL ELIMINATION

If you wish to have the microwave oven operate with no audible signals, touch Help, the number **2** and Stop/Clear pads.

To cancel and restore the audible signal, touch Help, the number **2** and Start/Touch On pads.

3. AUTO START

If you wish to program your microwave oven to begin cooking automatically at a designated time of day, follow this procedure:

- Suppose you want to start cooking a stew on 50% for 20 minutes at 4:30. Before setting, check to make sure the clock is showing the correct time of day.
 1. Touch Help pad.
 2. Touch number **3** to select the Auto Start.
 3. To enter the start time at 4:30, touch numbers **4****3****0**.
 4. Touch Clock pad.
 5. To enter cooking program, touch Power Level, number **5** for 50% power and then touch numbers **2****0****0****0** for cooking time.
 6. Touch Start/Touch On pad.

Note:

1. Auto Start can be used for manual cooking, Convec Broil, Convec Roast, Convec Bake, if clock is set.
2. If the microwave oven door is opened after programming Auto Start, it is necessary to touch the Start/Touch On pad for Auto Start time to appear in the readout so that the microwave oven will automatically begin programmed cooking at the chosen Auto Start time.
3. Be sure to choose foods that can be left in the microwave oven safely until the Auto Start time. Baked potatoes are often a good choice.

4. LANGUAGE SELECTION

The microwave oven comes set for English. To change, touch Help and the number **4** pads. Continue to touch the number **4** pad until your choice is selected. Then, touch Start/Touch On pad.

Touch number **4** once for English.

Touch number **4** twice for Spanish.

Touch number **4** three times for French.

5. WEIGHT AND TEMPERATURE SELECTIONS

The microwave oven comes set for U.S. Customary Unit-pounds. To change, touch Help and the number **5**. Continue to touch the number **5** until your choice is selected. Then, touch Start/Touch On pad.

Touch number **5** once for LB / °F.

Touch number **5** twice for KG / °C.

MULTIPLE SEQUENCE COOKING

The microwave oven can be programmed for up to 4 automatic cooking sequences for the microwave mode and 2 automatic cooking sequences with preheat for convection/mix mode, switching from one power level setting to another automatically.

Sometimes cooking directions tell you to start on one power level and then change to a different power level. Your microwave oven can do this automatically.

- Suppose you want to cook roast beef for 5 minutes at 90% and then continue to cook for 30 minutes at 50%.
 1. Touch Power Level pad once and touch number pad **9** for 90% power.
 2. Enter first cooking time by touching number pad **500**.
 3. Touch Power Level pad again and touch number pad **5** for 50% power.
 4. Then enter second cooking time by touching number pad **3000**.
 5. Touch Start/Touch On pad.

Note:

1. If Power Level pad is touched twice, HIGH will be displayed.
2. If you wish to know power level, simply touch the Power Level pad. As long as your finger is touching the Power Level pad, the power level will be displayed.

TIMER

- Suppose you want to time a 3 minute long distance phone call.
 1. Touch Timer pad.
 2. Enter time by touching the number pads **300**.
 3. Touch Start/Touch On pad.

MORE OR LESS TIME ADJUSTMENT

MORE: Should you discover that you like any of the Sensor, Sensor Cook, Defrost, Convec Broil, Convec Roast or Convec Bake settings slightly more done, touch the Power Level pad **once** after touching your choice of pads.

LESS: Should you discover that you like any of the Sensor, Sensor Cook, Defrost, Convec Broil, Convec Roast or Convec Bake settings slightly less done, touch the Power Level pad **twice** after touching your choice of pads.

ADD-A-MINUTE

Add-A-Minute allows you to cook for a minute at 100% by simply touching the Add-A-Minute pad. You can also extend cooking time in multiples of 1 minute by repeatedly touching the Add-A-Minute pad during manual cooking.

- Suppose you want to heat a cup of soup for one minute.

Touch Add-A-Minute pad.

Note:

1. To use Add-A-Minute, touch pad within 1 minute after cooking, closing the door, touching the Stop/Clear pad or during cooking.
2. Add-A-Minute cannot be used with Sensor, Sensor Cook, Defrost, Convec Broil, Convec Roast or Convec Bake.

TOUCH ON

Touch On allows you to cook at 100% power by touching the Start/Touch On pad continuously. Touch On is ideal for melting cheese, bringing milk to just below boiling etc.

The maximum cooking time is 3 minutes.

- Suppose you want to melt cheese on a piece of toast:
1. Continuously touch the Start/Touch On pad. The cooking time will begin counting up.
 2. When the cheese is melted to desired degree, remove finger from Start/Touch On pad. Microwave oven stops immediately.

Note:

1. Note time it takes for frequently used foods and program that time in the future.
2. To use Touch On, touch pad within 1 minute after cooking, opening and closing the door or touching the Stop/Clear pad.
3. Touch On can only be used 3 times in a row. If more times are needed, open and close door or touch Stop/Clear.

HELP (DISPLAY INDICATOR)

Each setting of Defrost, Convec Broil, Convec Roast, Convec Bake, Sensor Cook and Sensor has a cooking hint. If you wish to check, touch HELP pad whenever HELP is lighted in the Interactive Display for these hints.

DEMONSTRATION MODE

To demonstrate, touch Clock, the number **0** and then touch Start/Touch On pad and hold for 3 seconds. DEMO ON DURING DEMO NO OVEN POWER and DEMO will appear in the display. Cooking operations and specific special features can now be demonstrated with no power in the microwave oven. For example, touch Add-A-Minute pad and the display will show 1.00 and count down quickly to END.

To cancel, touch Clock, then the number **0** and Stop/Clear pads. If easier, unplug the microwave oven from the electrical outlet and replug.

CLEANING AND CARE

Disconnect the power cord before cleaning or leave the door open to inactivate the microwave oven during cleaning.

EXTERIOR

The outside surface is painted. Clean the outside with mild soap and water; rinse and dry with a soft cloth. Do not use any type of household or abrasive cleaner.

DOOR

Wipe the window on both sides with a damp cloth to remove any spills or spatters. Metal parts will be easier to maintain if wiped frequently with a damp cloth. Avoid the use of spray and other harsh cleaners as they may stain, streak or dull the door surface.

TOUCH CONTROL PANEL

Care should be taken in cleaning the touch control panel. If the control panel becomes soiled, open the microwave oven door before cleaning. Wipe the panel with a cloth dampened slightly with water only. Dry with a soft cloth. Do not scrub or use any sort of chemical cleaners. Close door and touch Stop/Clear pad.

INTERIOR - AFTER MICROWAVE COOKING

Cleaning is easy because little heat is generated to the interior surfaces; therefore, there is no baking and setting of spills or spattering. To clean the interior surfaces, wipe with a soft cloth and warm water. **DO NOT USE ABRASIVE OR HARSH CLEANERS OR SCOURING PADS.** For heavier soil, use baking soda or a mild soap; rinse thoroughly with hot water. **NEVER SPRAY OVEN CLEANERS DIRECTLY ONTO ANY PART OF THE MICROWAVE OVEN.**

INTERIOR - AFTER CONVECTION, MIX OR BROIL COOKING

Spatters may occur because of moisture and grease. Wash immediately after use with hot, soapy water. Rinse and polish dry. Harder to remove spatters may occur if microwave oven is not thoroughly cleaned or if there is long time/high temperature cooking. If so, you may wish to purchase an oven cleaner pad with liquid cleaner within it—not a soap filled steel pad—for use on stainless or porcelain surfaces. Follow manufacturer's directions carefully and be especially cautious not to get any of the liquid cleaner in the perforations on the wall or ceiling or any door surfaces. Rinse thoroughly and polish dry.

WAVEGUIDE COVER

The waveguide cover is made from mica so it requires special care. Keep the waveguide cover clean to assure good microwave oven performance. Carefully wipe with a damp cloth any food spatters from the surface of the cover immediately after they occur. Built-up splashes may overheat and cause smoke or possibly catch fire. Do not remove the waveguide cover.

ODOR REMOVAL

Occasionally, a cooking odor may remain in the microwave oven. To remove, combine 1 cup water, grated peel and juice of 1 lemon and several whole cloves in a 2-cup glass measuring cup. Boil for several minutes using 100% power. Allow to set in microwave oven until cool. Wipe interior with a soft cloth.

TURNTABLE/TURNTABLE SUPPORT

The ceramic turntable and turntable support can be removed for easy cleaning. Wash them in mild, sudsy water; for stubborn stains use a mild cleanser and scouring sponge as described above. They are also dishwasher-safe using top rack.

MICROWAVE OVEN RACKS

The high and low baking racks can be removed for easy cleaning and stored away from the microwave oven when racks are not needed. After each use, wash them in mild, sudsy water. For any stubborn stains, use a mild kitchen cleanser and scouring sponge as described above. They are dishwasher-proof.

GREASE FILTERS

Filters should be cleaned at least once a month. Never operate the fan or microwave oven without the filters in place.

1. Pull the ring toward the front of the microwave oven, down slightly and

remove the filter. Repeat for the other filter.

2. Soak the filters in a sink or dish pan filled with hot water and detergent. DO NOT use ammonia or other alkali; they will react with the filter material and darken it.
3. Agitate and scrub with a brush to remove embedded dirt.
4. Rinse thoroughly and shake dry.
5. Replace by fitting the filter back into the opening.

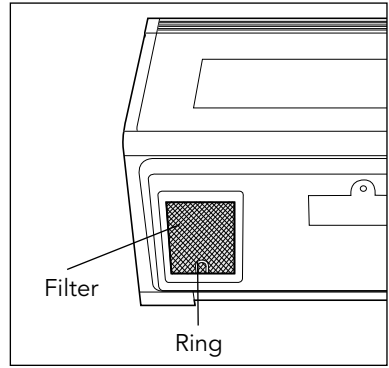

FAN

The fan will automatically start when heat rises from the cooking surface and when convection, high mix, low mix or the broil settings are used. This protects the microwave oven from excessive temperature rise. The fan will stay on until the temperature decreases. It cannot be turned off manually during this time.

For other uses, select either high or low speed.

PRECAUTIONS FOR PROPER USE:

1. DO NOT leave cooking surface unattended while using high temperatures. Automatic fan may start and provide excessive air to the surface units. This may cause spattering or boilover.
2. Avoid burning food.
3. Keep grease filters clean.

LIGHT

1. To replace light bulbs, first disconnect power to the microwave oven at the circuit breaker panel or by unplugging.
2. To release cover remove the screw on the light cover. (See illustration.)
3. Replace bulbs with only 20 watt and 40 watt bulbs. These are available at most hardware stores or lighting centers. The unit will be shipped with one 20 watt bulb and one 40 watt bulb. DO NOT USE A BULB LARGER THAN 40 WATTS.

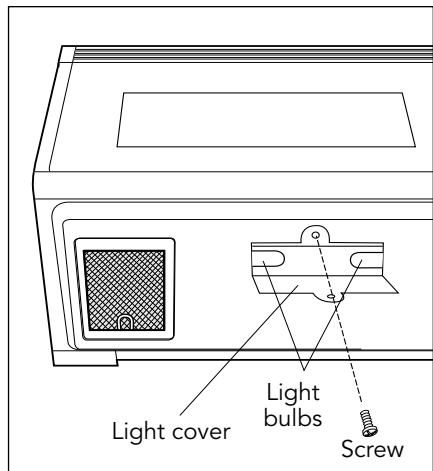

4. Close light cover and secure with screw removed in step 2.

Cautions: Light cover may become very hot. Do not touch glass when light is on. Do not use light for long time use such as a night light.

CHARCOAL FILTER

Charcoal Filter is used for Non-vented, recirculated installation. The filter should be changed every 6 to 12 months depending on use.

1. Disconnect power to the oven at the circuit breaker panel or by unplugging.
2. Remove 2 screws that secure louver.
3. Remove louver by gently moving louver and pull away from unit.
4. Slide Charcoal Filter into position on support tabs.
5. Push louver back into place and replace the 2 screws to secure louver.

MICROWAVE OVEN LIGHT

Remove the louver per instructions 1-3 above and charcoal filter, if used.

4. Slide the light cover forward and lift up.
5. Remove old light bulb and replace only with a 20 watt bulb available at most hardware stores or lighting centers. **DO NOT USE A BULB LARGER THAN 30 WATTS.**
6. Replace the microwave oven light cover and charcoal filter, if used; push louver back in place and replace the louver mounting screws.

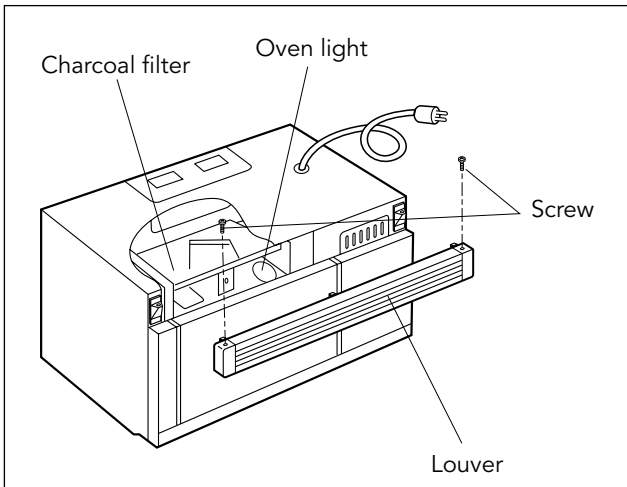

SPECIFICATIONS

AC Line Voltage:	UL Rating - Single phase 120V, 60Hz, AC only CSA Rating - Single phase 116V, 60Hz, AC only
AC Power Required:	UL Rating - Microwave 1.60 kw, 13.2 amps. UL Rating - Convection 1.60 kw, 13.2 amps. CSA Rating - Microwave 1.5 kw, 13.0 amps. CSA Rating - Convection 1.5 kw, 13.0 amps.
Output Power	
Microwave:	850 watts*
Convection Heater:	1400 watts
Frequency:	2450 MHz
Outside Dimensions:	29 ¹⁵ / ₁₆ "(W) x 16 ¹¹ / ₃₂ "(H) x 15 ⁹ / ₃₂ "(D)
Cavity Dimensions:	17 ¹ / ₈ "(W) x 8 ¹ / ₁₆ "(H) x 13 ¹³ / ₁₆ "(D)
Microwave oven Capacity:**	1.1 Cu. Ft.
Cooking Uniformity:	Turntable and Stirrer Fan
Weight:	Approx. 71 lb

* The International Electrotechnical Commission's standardized method for measuring output wattage. This test method is widely recognized.

** Internal capacity is calculated by measuring maximum width, depth and height. Actual capacity for holding food is less.

In compliance with standards set by:

FCC – Federal Communications Commission Authorized.

DHHS – Complies with Department of Health and Human Services (DHHS) rule, CFR, Title 21, Chapter I, Subchapter J.

 – This symbol on the nameplate means the product is listed by Underwriters Laboratories, Inc. for use in USA or Canada.

NHW – Department of National Health and Welfare of Canada.

This microwave oven is listed by the Canadian Standard Association as certified.

SERVICE CALL CHECK

Please check the following before calling for service:

1. Place one cup of water in a glass measuring cup in the microwave oven and close the door securely.

Operate the microwave oven for one minute at HIGH 100%.

A Does the microwave oven light come on? YES _____ NO _____

B Does the cooling fan work? YES _____ NO _____
(Put your hand over the rear ventilating openings.)

C Does the turntable rotate? YES _____ NO _____
(It is normal for the turntable to turn in either direction.)

D Is the water in the microwave oven warm? YES _____ NO _____

2. Remove water from the oven and operate the oven for 5 minutes at Convec 450°F.

Operate the microwave oven for one minute at HIGH 100%.

A Do CONV and COOK indicators light? YES _____ NO _____

B After the oven shuts off, is inside of the microwave oven hot? YES _____ NO _____

If "NO" is the answer to any of the above questions, please check electrical outlet, fuse and/or circuit breaker. If they are functioning properly, CONTACT YOUR NEAREST VIKING AUTHORIZED SERVICER.

A microwave oven should never be serviced by a "do-it-yourself" repair person.

Note: If time appearing in the display is counting down very rapidly, check Demonstration Mode on page 38 and cancel.

MICROWAVE OVEN WARRANTY

ONE YEAR FULL WARRANTY

Viking Microwave Oven and all of their component parts and accessories, except as detailed below*, are warranted to be free from defective materials or workmanship in normal household use for a period of twelve (12) months from the date of original retail purchase. Viking Range Corporation, warrantor, agrees to repair or replace, at its option, any part which fails or is found to be defective during the warranty period.

Glass (including light bulbs), painted and decorative items are warranted to be free from defective materials or workmanship for a period of ninety (90) days from the date of original retail purchase. ANY DEFECTS MUST BE REPORTED TO THE SELLING DEALER WITHIN NINETY (90) DAYS FROM DATE OF ORIGINAL RETAIL PURCHASE.

FIVE YEAR LIMITED WARRANTY

If the magnetron tube fails due to defective materials or workmanship in normal household use during the second through fifth year from the date of original retail purchase it will be repaired or replaced, free of charge for the part itself, with the owner paying all other costs, including labor.

This warranty extends to the original purchaser of the product warranted hereunder and to each transferee owner of the product during the term of the warranty.

This warranty shall apply to products purchased and located here in the United States and Canada. Products must be purchased in the country where service is requested. Warranty labor shall be performed by an authorized Viking Range Corporation service agency or representative. Warranty shall not apply to damage resulting from abuse, accident, natural disaster, loss of electrical power to the product for any reason, alteration, outdoor use, improper installation, improper operation or repair or service of the product by anyone other than an authorized Viking Range Corporation service agency or representative. This warranty does not apply to commercial usage. Warrantor is not responsible for consequential or incidental damage whether arising out of breach of warranty, breach of contract, or otherwise. Some jurisdictions do not allow the exclusion or limitation of incidental or consequential damages, so the above limitation or exclusion may not apply to you.

Owner shall be responsible for proper installation, providing normal care and maintenance, providing proof of purchase upon request, and making the appliance reasonably accessible for service. If the product or one of its component parts contains a defect or malfunction during the warranty period, after a reasonable number of attempts by the warrantor to remedy the defects or malfunctions, the owner is entitled to either a refund or replacement of the product or its component part or parts. Warrantor's liability on any claim of any kind, with respect to the goods or services covered hereunder, shall in no case exceed the price of the goods or service or part thereof which gives rise to the claim.

WARRANTY SERVICE: Under the terms of this warranty, service must be performed by a factory authorized Viking Range Corporation service agent or representative. Service will be provided during normal business hours, and labor performed at overtime or premium rates shall not be covered by this warranty. To obtain warranty service, contact the dealer from whom the product was purchased, an authorized Viking Range Corporation service agent, or Viking Range Corporation. Provide model and serial number and date of original purchase. For the name of your nearest authorized Viking Range Corporation service agency, call the dealer from whom the product was purchased or Viking Range Corporation. **IMPORTANT:** Retain proof of original purchase to establish warranty period.

The return of the Owner Registration Card is not a condition of warranty coverage. You should, however, return the Owner Registration Card so that Viking Range Corporation can contact you should any question or safety arise which could affect you.

Any implied warranties of merchantability and fitness applicable to the above described elements or parts are limited in duration to the period of coverage of the applicable express written limited warranties set forth above. Some jurisdictions do not allow limitations on how long an implied warranty lasts, so the above limitation may not apply to you. This warranty gives you specific legal rights, and you may also have other rights which may vary from jurisdiction to jurisdiction.

Viking Range Corporation

111 Front Street

Greenwood, Mississippi (MS) 38930 USA (888) 845-4641

Specifications subject to change without notice

For more product information, call 1-888-VIKING1 (845-4641)

or visit the Viking web site at <http://www.vikingrange.com>