

Frigidaire

Factory Parts Catalog

Product No.	FRT17HB3JW2	FRT17HB3JZ2
Series	R134a	R134a
Color	white (RH)	white (LH)
Volts	115	115
Wiring Diagram	241582401	241582401
Owner's Guide	241857201	241857201
Market	North America	North America
Energy Guide	241868082	241868082
Service Data Sheet	241588203	241588203
Installation Instructions	240568303	240568303

 **Electrolux**

Electrolux Major Appliances
North & Latin America
P.O. BOX 212378
AUGUSTA, GA 30917

Publication No.
5995518957
08/07/16
(EN/SERVICE/KHB)
390

**TOP-MOUNT
REFRIGERATOR**

**Model No.
FRT17HB3J**

Copyright © 2008 Electrolux Home Products, Inc.
All rights reserved.

DOOR

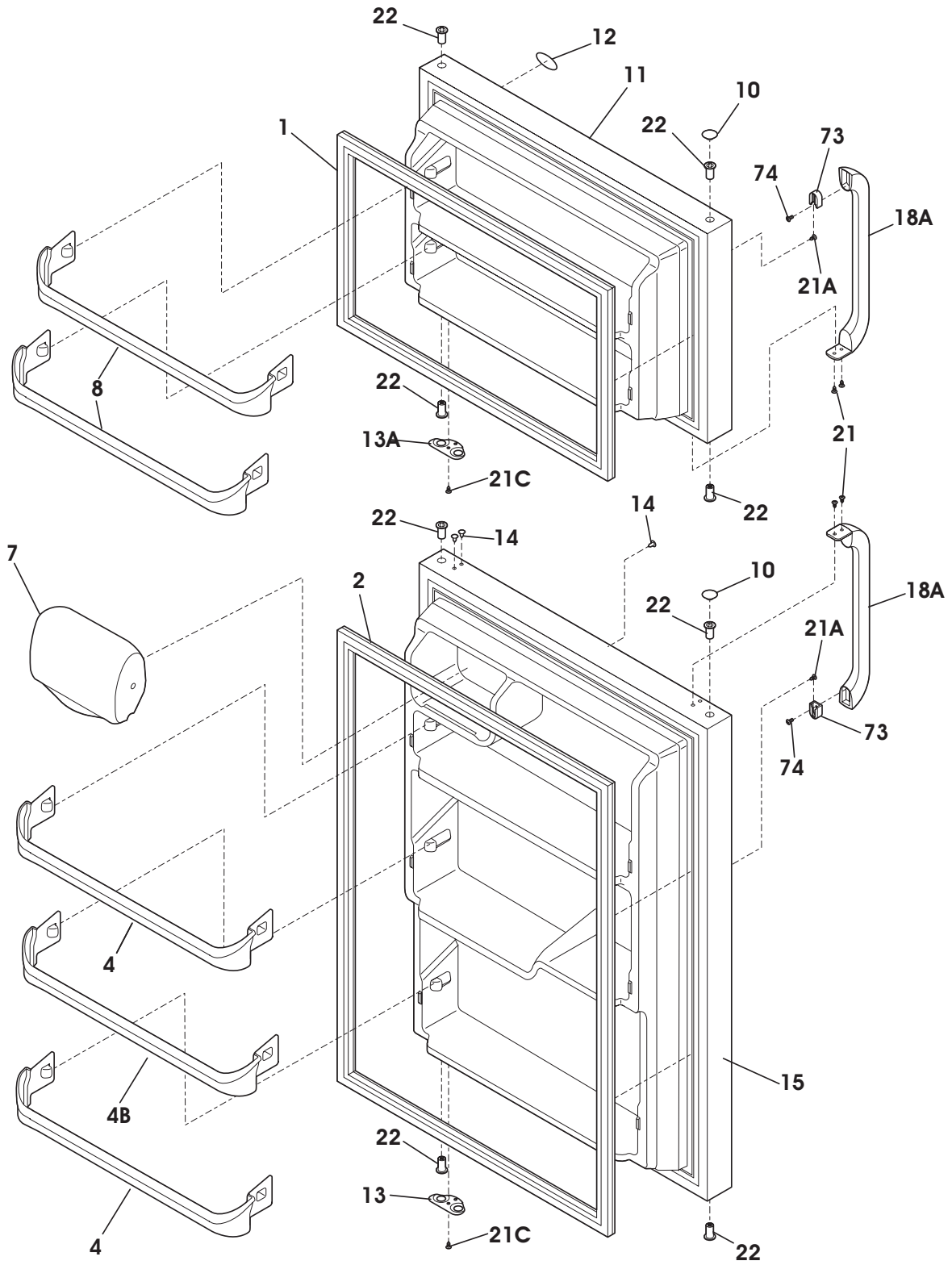

N05DBDCKA0

DOOR

Model Index: A FRT17HB3J (FRT17HB3JW2)
 B FRT17HB3J (FRT17HB3JZ2)

POS. NO	PART NO.		DESCRIPTION
1 #	241872501	A B	Gasket-frzr door, white, magnetic
2 #	241872504	A B	Gasket-refr door, white, magnetic
4	240535101	A B	Rack-door
4B	240535201	A B	Rack-door
7	240337712	A B	Door-dairy
8	240535001	A B	Rack-door
10	240381301	A B	Plug-button, white, hinge brg hole, (2)
11	240420101	A B	Door, frzr, white
12	241808601	A B	Label-nameplate
13	240312403	A B	Door Stop, white, ref
13A	240312404	A B	Door Stop, white, frzr
14	240494001	A B	Plug-button, white
15	240420201	A B	Door, refr, white
18A	218428101	A B	Handle-door, white, w/block & screw
21	240383406	A B	Screw, truss hd quad, #10-16 x .500, zinc
21A	240521303	A B	Screw, #10-16 x 1/2
21C	218252201	A B	Screw, #8 truss hd, 10-32CA x 0.500
22	240527101	A B	Bearing-hinge, natural color
73	218396701	A B	Block-handle mtg, dovetail
74	215503203	A B	Screw, cr pan hd, 10-16 x 0.500

CABINET

Model Index: A FRT17HB3J (FRT17HB3JW2)
B FRT17HB3J (FRT17HB3JZ2)

POS. NO	PART NO.		DESCRIPTION
1	241652301	A B	Cover-fan
2	240367001	A B	Knob-damper control
3	5303001028	A B	Nut, push-on
4	241523701	A B	Damper-fan cover
5 #	5308000010	A B	Fan Blade, red, evaporator fan
8	5300157666	A B	Bushing-motor mtg, (2)
9	5303292396	A B	Bracket-motor mtg, front
10	241652215	A B	Cover-evap coil
10*	240568601	A B	Seal-coil cover
11	5303208309	A B	Plug-hole, factory test
12	241557601	A B	Plug-ice maker harness, rectangular
12A	240374401	A B	Plug-wtr inlet tube, round, 1"
12A*	241586701	A B	Plug-foam-wtr-inlet, round
13 #	241854301	A B	Motor-fan
13*	215474201	A B	Washer, "slinger", nylon, evap fan shaft
13*	218931001	A B	Clamp-motor wiring, nylon, w/adhesive tape
14	5303292397	A B	Bracket-motor mtg, rear
14*	240433204	A B	Screw, hex washer head, 8-18 x 5/16
21C	218252201	A B	Screw, #8 truss hd, 10-32CA x 0.500
22	215774901	A B	Plug-button, white, upr hinge holes
30	240357106	A B	Bracket-lower hinge
34	240311303	A B	Washer, hinge, nylon, (2)
35	240357006	A B	Bracket-ctr hinge
35A	240336802	A B	Spacer-hinge, center
36	240516402	A B	Pin-center hinge
37	241611301	A B	Trim-cabinet corner, white, (2)
38	240356901	A B	Bracket, upper hinge
40	240354401	A B	Cover-upper hinge, white
41	5308009759	A B	Grommet, shelf mtg, 1.25", LH, (4)
42	240578902	A B	Screw, hex head, 1/4-20 x 5/8
43	241889002	A B	Roller Assy, front LH, (2)
43*	241889001	A B	Roller Assy, front RH, (2)
56	240516502	A B	Pin-lower hinge
58	5304456287	A B	Screw, hex washer head, 8-15A x 0.500
59	240442706	A B	Screw-#10-32 X 3/4, zinc
72	240368301	A B	Grille/Kickplate, white
81	5304455650	A B	Screw, hex washer head, 8-15A x 0.625, low profile
82	5304418225	A B	Roller, compressor base, rear, (2)
83	5304455655	A B	Rivet, flat head, 1/4 OD x 1-3/4, roller pin
89	241733906	A B	Cover-access, with label
89*	241500304	A B	Screw, hex washer head, 8-18AB x 0.625
92	241710601	A B	Screw, hex washer hd, 1/4 x 7/8, hinge mtg
*	240479601	A B	Plug, button, cab liner holes
*	5303321319	A B	Paint, touch-up, white

SHELVES

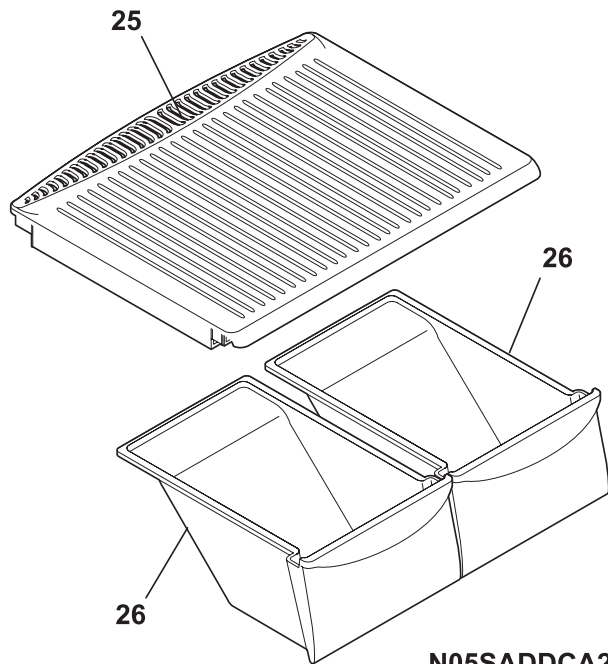
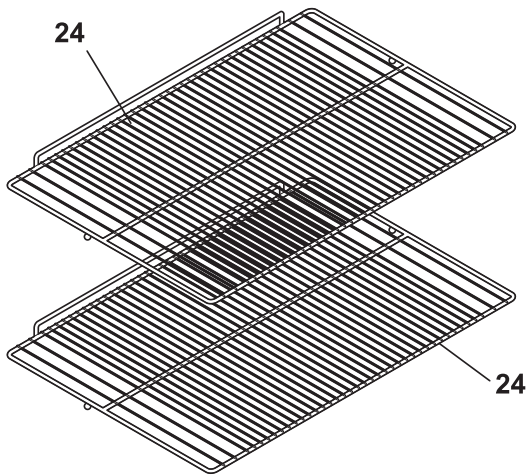
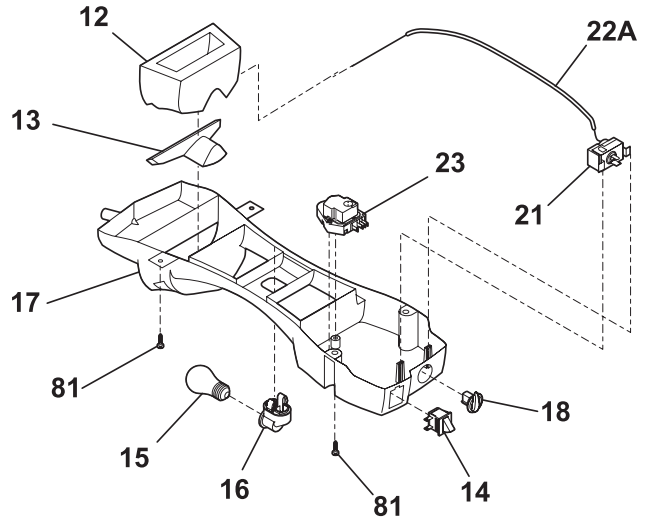
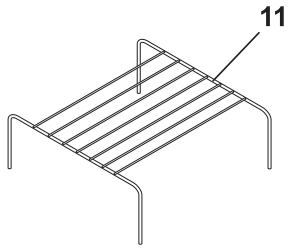

N05SADDCA21

SHELVES

Model Index: A FRT17HB3J (FRT17HB3JW2)
 B FRT17HB3J (FRT17HB3JZ2)

POS. NO	PART NO.		DESCRIPTION
11	5303282284	A B	Shelf-freezer, "table type"
12	241542001	A B	Diffuser, air, top
13	240362601	A B	Diffuser, air, bottom
14 #	241554901	A B	Switch-light/lamp
15	241555401	A B	Light Bulb
16	241559801	A B	Socket-light
17	240368002	A B	Control Box
17*	240568607	A B	Seal
17*#	240388701	A B	Wiring Harness, control box
18	240360801	A B	Knob, temp control
21 #	5304421256	A B	Control, temperature
22A	240468201	A B	Tube, sensor sleeve, 31 inch, plastic, white
23 #	241621501	A B	Timer-defrost
23*	5304455649	A B	Screw, pan hd, 6-20 x 0.438
24	240360902	A B	Shelf, sliding, wire
25	240364706	A B	Cover, crisper pan
26	240364503	A B	Pan, crisper, (2)
81	5304455650	A B	Screw, hex washer head, 8-15A x 0.625, low profile
*	241868082	A B	Energy Guide

SYSTEM

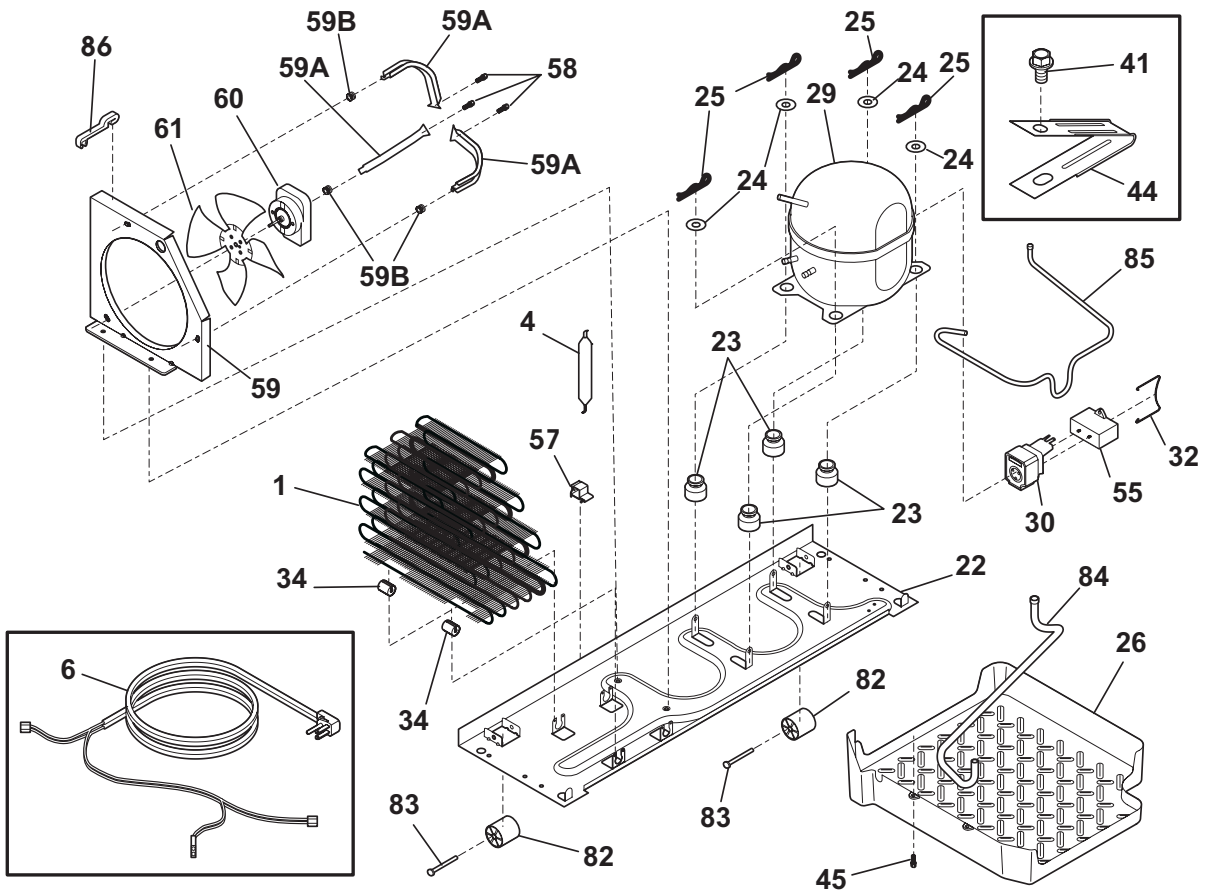
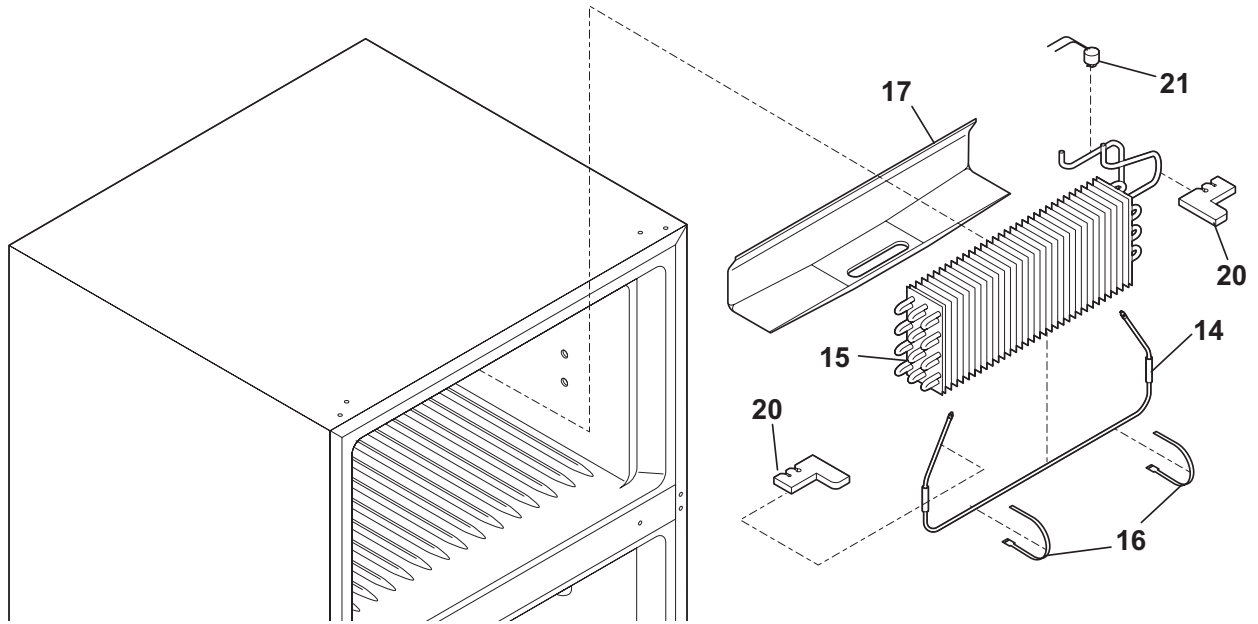

N05CAABAD4

SYSTEM

Model Index: A FRT17HB3J (FRT17HB3JW2)
 B FRT17HB3J (FRT17HB3JZ2)

POS. NO	PART NO.		DESCRIPTION
1 #	241873404	A B	Condenser
4	218944002	A B	Drier-filter, R134a System
6 #	241607001	A B	Harness-wiring, machine compt
6*	240388701	A B	Wiring Harness, control box
14 #	241940101	A B	Heater-defrost
15 #	5303918275	A B	Evaporator Kit
16	5308000110	A B	Strap-evap/heater, aluminum, (2)
17	241801302	A B	Trough-drain
20	241551902	A B	Insulation Block
21 #	5303918202	A B	Thermostat-defrost, kit
22	241665605	A B	Base-compressor
22*	218252201	A B	Screw, #8 truss hd, 10-32CA x 0.500
23	218513300	A B	Grommet-compr mtg, (4)
24	241812301	A B	Washer-compr mtg
25	216056401	A B	Clip-compressor mtg
26	241683601	A B	Pan-defrost
29 #	5303918380	A B	Compressor Kit
30 #	241941001	A B	Starter
32	297030500	A B	Clip, controller
34	240405201	A B	Grommet, rubber, black, cond tube/wire
41	240433204	A B	Screw, hex washer head, 8-18 x 5/16
44	5304456288	A B	Clamp-wiring harness, strain relief, galv steel
45	241500304	A B	Screw, hex washer head, 8-18AB x 0.625
55	218909913	A B	Capacitor, run, 220 VAC, 15 microfarad
57	240542601	A B	Clip-wiring harness
58	240569201	A B	Screw, 8-18 x 0.500
59	240315502	A B	Shroud-cond fan
59*	240346701	A B	Tape-foam seal, shroud
59*	240359403	A B	Screw-fan shroud, (2)
59A	240346501	A B	Bracket-support, cond mtr, (3)
59B	240346601	A B	Grommet-bracket, (3)
60	241584301	A B	Motor-condenser fan
61	241639501	A B	Blade-condenser fan
82	5304418225	A B	Roller, compressor base, rear, (2)
83	5304455655	A B	Rivet, flat head, 1/4 OD x 1-3/4, roller pin
84	240500801	A B	Tube-drain, rubber, lower
85	241871501	A B	Tube-connector, suction
86	240409302	A B	Spacer-cond tube, black
* #	240396801	A B	Clamp, tube/wiring, nylon, black/natural
* #	5303918263	A B	Heat Exchanger Kit, suction line
*	5303918222	A B	Hot Tube Repair Kit, service

WIRING SCHEMATIC

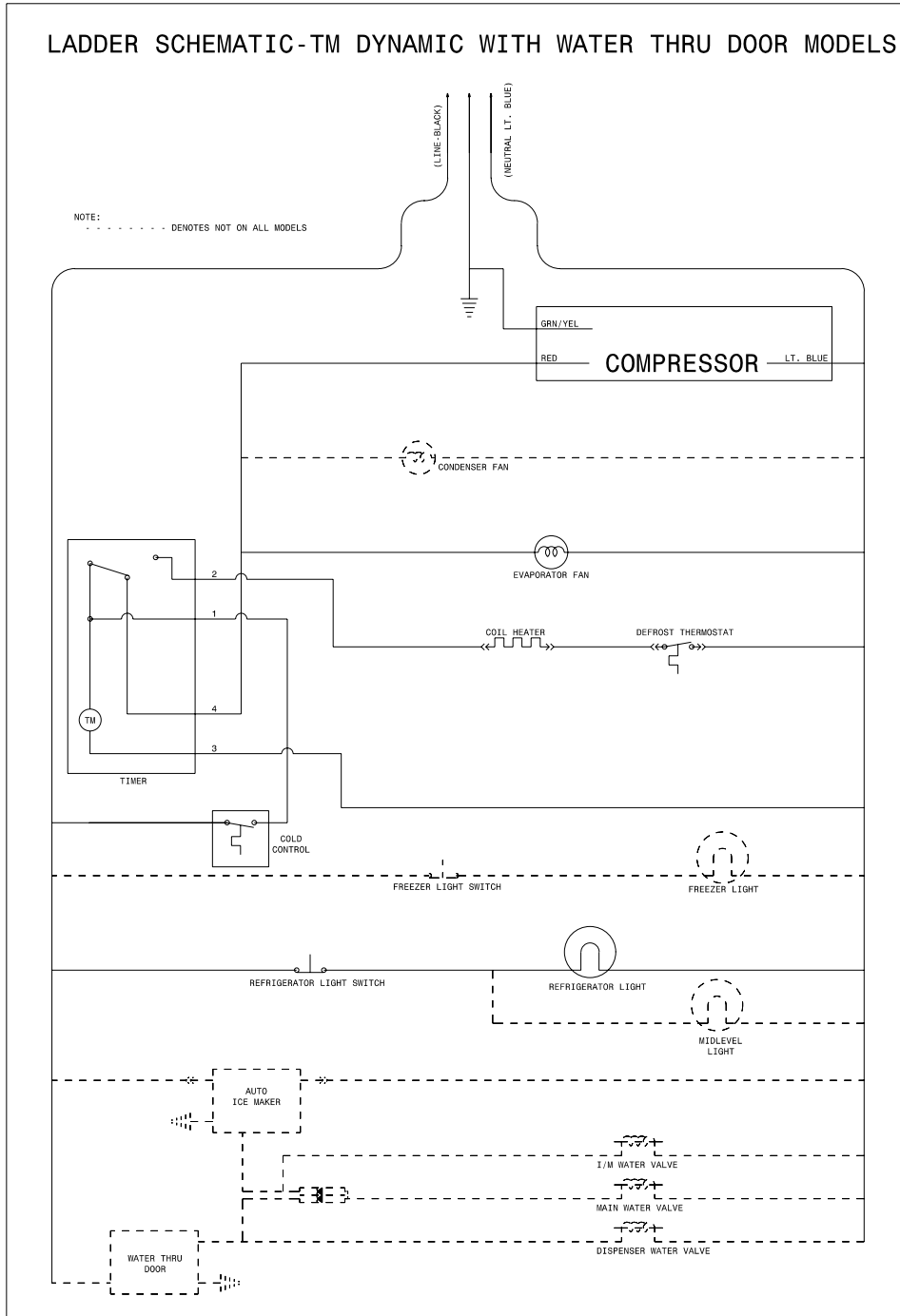

WIRING DIAGRAM

