

FU67-5



60CM (approx 24") Thermo-ventilated Electric Multifunction Oven Polished Stainless Steel

Multifunction oven with 8 cooking modes

Exclusive Piano Design
Ergonomic control knobs
Analogue clock, with timer and cooking start and ending time alarm (oven switches off automatically)
Air cooled door
Triple glazed door with heat reflective inner layer
Light reflective stainless steel oven interior
Rapid heating variable broiler
Full width or 1/2 broiler
2 Halogen lamps

Oven capacity: 2.13 Cu.Ft.
Usable oven capacity: 1.87 Cu.Ft.
Interior dimensions: W 17 3/8" x H 11 7/8" x D 15 5/16"
Bake element: 1300W at 240V - 1000W at 208V
Broil element: 2000W at 240V - 1500W at 208V
Convection element: 3000W at 240V - 2200W at 208V

Voltage rating: 240/208V - 60Hz
Connected load (nominal power): 240/208V- 3.3/2.5kW

Amps @ 240/208V: 13.8/12
Power supply location: Back right bottom

ACCESSORIES INCLUDED:
1 Glass roasting/broiler pan
1 broiler rack
1 Wire rack

FUNCTIONS



SMEG USA INC.
A&D BUILDING
150 EAST 58th STREET
7th FLOOR
NEW YORK, NY, 10155

FU67-5



60CM (approx 24") Thermo-ventilated Electric Multifunction Oven Polished Stainless Steel



		<p>Top and bottom heat: This method is known as "conventional" cooking, and is suitable for dishes that require a more gentle heat, such as baking. The oven needs to be pre-heated to the required temperature, and is best suited for single items, such as large cakes. Best results are obtained by placing food in the centre of the oven.</p>
		<p>Intensive broil: This allows rapid cooking and browning of foods. Best results can be obtained from using the top rack for small items, the lower racks for larger items, such as chops or sausages. Cooking using this method should be carried out with the door closed, unless instructed to do otherwise.</p>
		<p>Broil: Heat is generated only at the centre of the element, ideal for smaller cuts of meat.</p>
		<p>Convection broil: Please note: cooking in this mode is conducted with the door closed. The fan reduces the fierce heat from the broiler, providing an excellent method for broiling a range of foods; chops, steaks, sausages etc. without having to turn the food during cooking. This gives good results, reduces drying out of foods, and gives even browning and heat distribution, the top two racks being recommended for use. The lower area of the cavity can also be used to keep other items warm at the same time.</p>
		<p>Convection with top and bottom heat: The elements combined with the fan aim to provide more uniform heat. This is a similar method to conventional cooking, so pre-heat is required. This is not as effective as european convection cooking but can be used to cook biscuits and pastry.</p>
		<p>Convection with bottom heat: This combination quickly completes the cooking of foods that are ready on the surface, but require more cooking inside, without further browning. Suitable for any type of food.</p>
		<p>European convection: The combination of the fan and circular element around it, gives uniform heat distribution with no cold spots. This has benefits - no preheat if cook time is more than 20 minutes, no flavour transfer when cooking different foods the same time, less energy is needed, and it cooks at 10% quicker than a normal oven.</p>
		<p>Defrost: The circulation of air at room temperature enables quicker thawing of frozen food, (without the use of any heat). Ideal for use prior to cooking of readymade dishes, or cream filled products etc.</p>

FU67-5



60CM (approx 24") Thermo-ventilated Electric Multifunction Oven Polished Stainless Steel

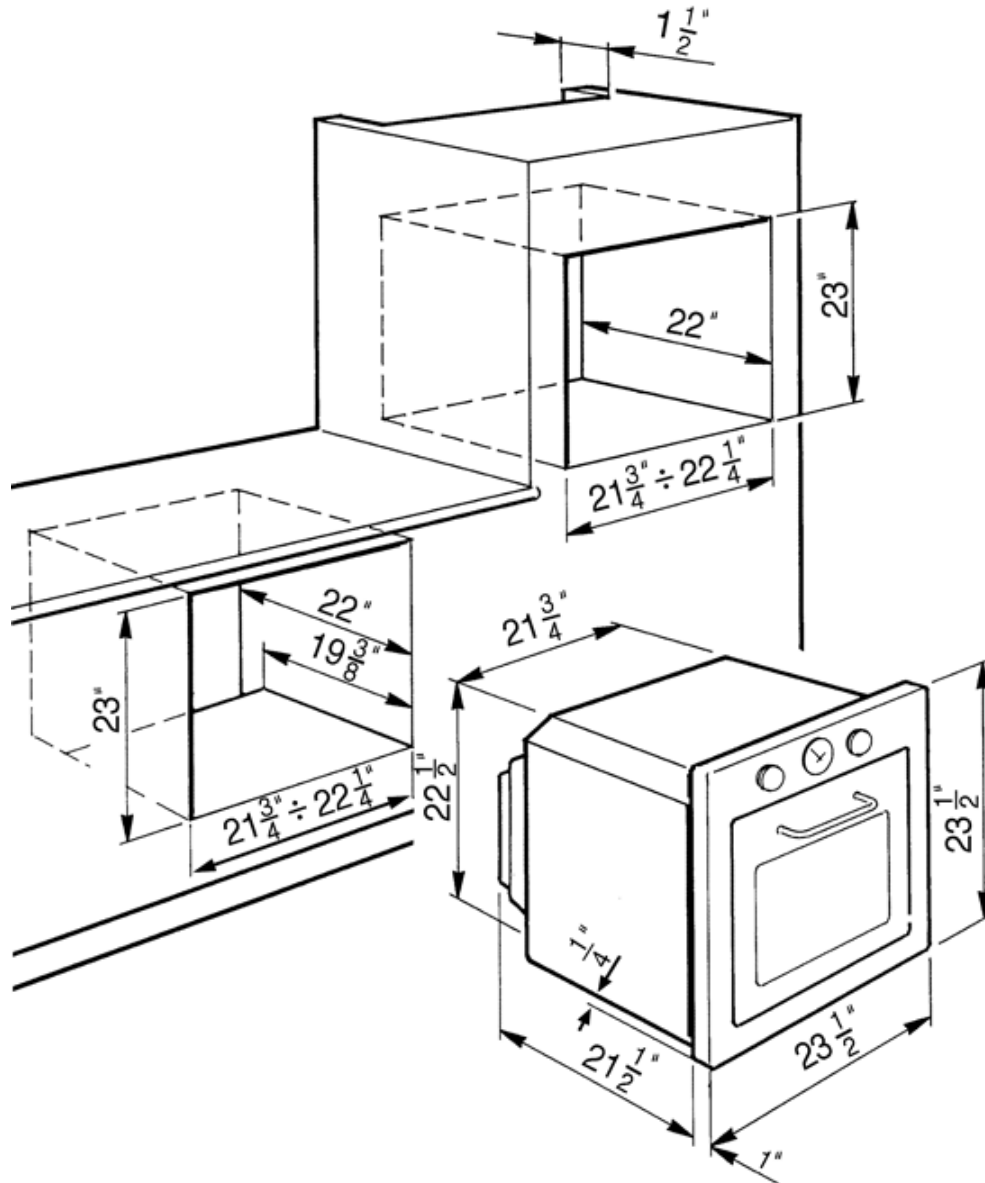

SMEG USA INC.
A&D BUILDING
150 EAST 58th STREET
7th FLOOR
NEW YORK, NY, 10155