

# S2773CXU



Ceramic Cooktop, 76 cm (approx. 30" ),  
Stainless Steel Frame

5 High-Light radiant zones:

Front right: 1,200 W - @ 5 ½" (140mm)

Back right: 1,100 + 1,300 W - @ 5 ½" - 8 ¼"  
(140-210mm)

Central: 1,400 + 800 W - @ 5 ½" x 10 7/16"  
(140 x 265mm)

Front left: 1,800 W - @ 7" (180mm)

Back left: 1,200 W - @ 5 ½" (140mm)

Elegant stainless steel frame

"Suprema" black ecological glass

Soft touch controls

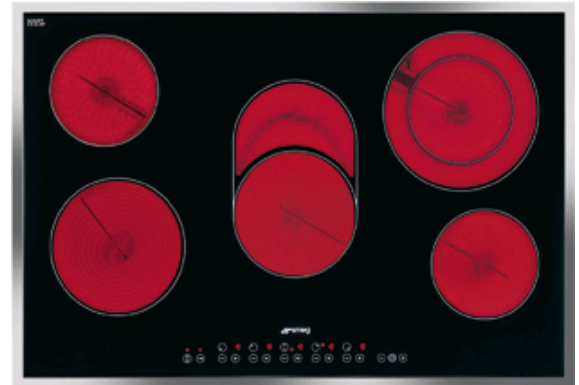

5 high-light radiant elements, including 2 variable  
zones

9 power levels for each zone

Residual heat indicator for each zone

Automatic safety cut-out

Individual timer for each zone (1 - 99min)

Safety lock device

ACCESSORIES INCLUDED:

1 Cleaning scraper

Voltage rating: 240/208V - 60Hz

Connected load (nominal power): 240/208V-

9.5/7.2kW

Amps @ 240/208V: 40/35

Electrical - single phase 3 or 4 wire cable  
required, 120/240V or 120/208V, 60Hz, fused on  
both sides of line with ground.

**SMEG USA INC.  
A&D BUILDING  
150 EAST 58th STREET  
7th FLOOR  
NEW YORK, NY, 10155**

# S2773CXU



Ceramic Cooktop, 76 cm (approx. 30" ),  
Stainless Steel Frame

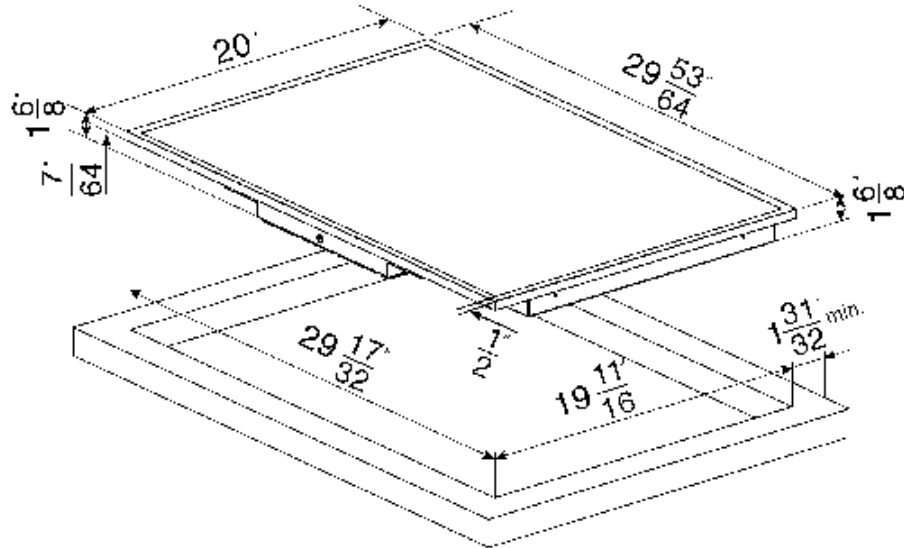

**SMEG USA INC.**  
A&D BUILDING  
150 EAST 58th STREET  
7th FLOOR  
NEW YORK, NY, 10155