

48" GAS RANGES

RGS-484GG | RGS-486GD | RGS-486GL | RGS-485GD
48" Gas Range with Griddle and Grill (as shown) | RGS-484GG



PROFESSIONAL CHEFS DEMAND PERFORMANCE WHEN THEY COOK. SO SHOULD YOU. BECAUSE DCS IS THE ONLY MAJOR MANUFACTURER TO CRAFT BOTH COMMERCIAL AND RESIDENTIAL COOKING EQUIPMENT, WE HAVE A UNIQUE EXPERIENCE IN CREATING PRODUCTS WITH EXCEPTIONAL PERFORMANCE.

OUR TIRELESS PURSUIT OF PROFESSIONAL PERFORMANCE HAS LEAD TO SEVERAL UNIQUE FEATURES, MANY OF WHICH YOU WILL NOT FIND ON OTHER RESIDENTIAL COOKING EQUIPMENT.

FASTER BOILING TIME: There are some occasions in cooking when you simply need more power; when preparing fried tempura, sautéed noodles or blanched vegetables, for example. The DCS sealed Dual Flow Burners™ deliver 17,500 Btu's, the most in the category. Simply stated, nothing boils water faster. This means more impressive dinner in a shorter time.

CONSISTENTLY LOWER SIMMER TEMPERATURE: Turn other residential burners down to simmer and the flame looks much the same as before, only smaller. Not so at DCS. The primary flame on our sealed Dual Flow Burners™ shuts off automatically when you turn it to simmer, leaving a smaller "retention flame" burning. This allows you to maintain a constant simmer temperature as low as 140 degrees, for an efficient and safe simmer. This means no more scalding delicate sauces.

GRIDDLE, GRILL OR BOTH: Our 48" ranges are available with your choice of an 18,000 Btu Griddle, Grill or both. Not to mention our patented 5-burner configuration that features an oversized 17" griddle.

- Grill models incorporate our ceramic radiant technology that provides intense and even radiant heat across the entire grilling surface. In addition to our patented Grease Management System™ that reduces flare-ups by effectively channeling oils and grease away from the flame and into a removable stainless steel drip-tray.
- Griddle models utilize a commercial grade stainless steel, Blanchard ground griddle that ensures a level cooking surface and even heat distribution.

INFRARED BROILER: Our infrared gas broiler heats up to broil temperature in no time and provides intense and even radiant heat. This ensures that your precious steak is truly broiled not baked, locking in natural flavor and juices.

MORE EXCEPTIONAL FEATURES: DCS gas ranges include a large convection oven that is able to accommodate commercial size baking pans (18"x 26"). Sealed range tops have been designed for easy cleanup. Platform style surface grates allow you to move heavy pots and pans from one burner to another without lifting. This means easier and safer cooking

At DCS we couple power with precision to attain your most essential cooking ingredient: PERFECT HEAT™.



PERFECT HEAT™

GAS RANGES

Possible Range Top Configurations:

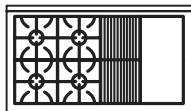

RGS-484GG



RGS-486GD

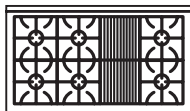

RGS-486GL

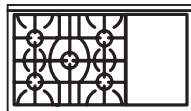

RGS-485GD

MODEL NUMBER	RGS-484GG	RGS-486GD	RGS-486GL	RGS-485GD
# OF SEALED, DUAL FLOW BURNERS™	4	6	6	5
DUAL FLOW BURNER™ Btu/hr*	17,500	17,500	17,500	17,500
GRILL Btu/hr*	18,000		18,000	
GRIDDLE Btu/hr*	18,000	18,000		26,000
SEALED RANGE TOP	•	•	•	•
PRIMARY / SECONDARY OVEN SPACE	5.3/2.2 cu. ft.	5.3/2.2 cu. ft.	5.3/2.2 cu. ft.	5.3/2.2 cu. ft.
INFRARED BROILER	•	•	•	•
CONVECTION OVEN	•	•	•	•
OVEN RACKS / POSITION	3/4	3/4	3/4	3/4
SECONDARY OVEN RACKS/POSITIONS	2/4	2/4	2/4	2/4
POWER: COOKTOP/OVEN	Gas	Gas	Gas	Gas
BAKE: PRIMARY Btu/hr*	30,000	30,000	30,000	30,000
BAKE: SECONDARY Btu/hr*	18,000	18,000	18,000	18,000
BROIL: PRIMARY Btu/hr*	19,000	19,000	19,000	19,000
SHIPPING WEIGHT, LBS.	600	600	600	600

*Btu ratings shown for Natural gas only. Propane Btu ratings may vary.

Power Requirements:

- ▶ 120V 60Hz
- ▶ 3 wire 15 amp circuit

Gas Requirements:

- ▶ 1/2 NPT, Min. 5/8" dia. flex line
- ▶ Pressure: 6" to 14" W.C. (Nat.)
- ▶ Pressure: 11" to 14" W.C. (LP)

Recommended Accessories:

VENTILATION:

- ▶ Wall Mount Vent Hood (VH-48)
- ▶ Island Vent Hood (IVH-48)
- ▶ Grill models require 1,200 CFM

BACKGUARD SYSTEM:

- ▶ Low backguard (model BGS-1248)
- ▶ Full backguard (model BGS-3048)
- ▶ Range ships standard with 2" integral island trim

Available Colors:

RANGE COLORS:

- ▶ Stainless Steel
- ▶ Black
- ▶ White

HANDLE / TRIM OPTION:

- ▶ Brass

Ordering Data:

- ▶ Please specify color and/or brass trim when ordering
- ▶ Please specify gas type (natural or propane) when ordering

Warranty

All Gas Ranges are covered by a one (1) year comprehensive parts and labor warranty. In addition, a five (5) year limited parts warranty covers specific parts that vary by model. Please see the product Use and Care Manual for the specified parts covered under this warranty. A lifetime warranty covers all stainless steel components against manufacture related defects. This excludes discoloration or surface corrosion resulting from improper use and care. Please refer to product Use and Care Manual for proper care and maintenance.



Because of continuing product improvement these specifications are subject to change without notice.

Product Dimensions:

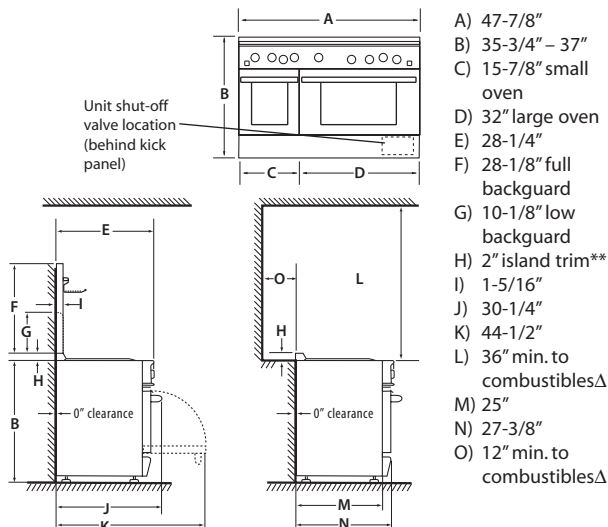

- A) 47-7/8"
- B) 35-3/4" – 37"
- C) 15-7/8" small oven
- D) 32" large oven
- E) 28-1/4"
- F) 28-1/8" full backguard
- G) 10-1/8" low backguard
- H) 2" island trim**
- I) 1-5/16"
- J) 30-1/4"
- K) 44-1/2"
- L) 36" min. to combustiblesΔ
- M) 25"
- N) 27-3/8"
- O) 12" min. to combustiblesΔ

**All RGS-48 ranges are shipped standard with non-removable 2" integral island trim and may be installed with 0" clearance from non-combustible material and 12" clearance from combustible material. If installing with less than a 12" clearance from combustible material, one of the two DCS wall mount backguards is required.

Cabinet Preparation:

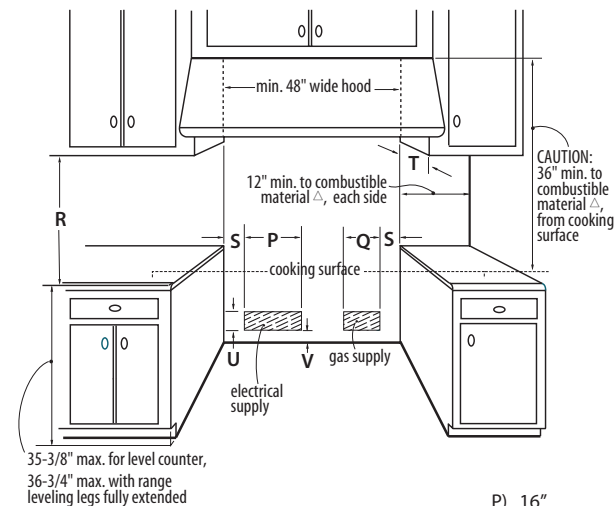

- P) 16"
- Q) 12"
- R) 18" min.
- S) 8"
- T) 13" max.
- U) 3-1/4"
- V) 3-1/2"

Δ As defined in the "National Fuel Gas Code" (ANSI Z223.1, latest edition).

The horizontal surfaces of the range top (cooktop) trim must not be below countertop level.



PERFECT HEAT.™

For more information on our complete line of residential kitchen appliances or to find out more about our outdoor product line, please call 1.800.433.8466 or visit www.dcsappliances.com

©2003 DCS 5800 Skylab Road, Huntington Beach, CA 92647

P/N 17461 REV. A 01/03