

WARMING DRAWER

USE AND CARE MANUAL

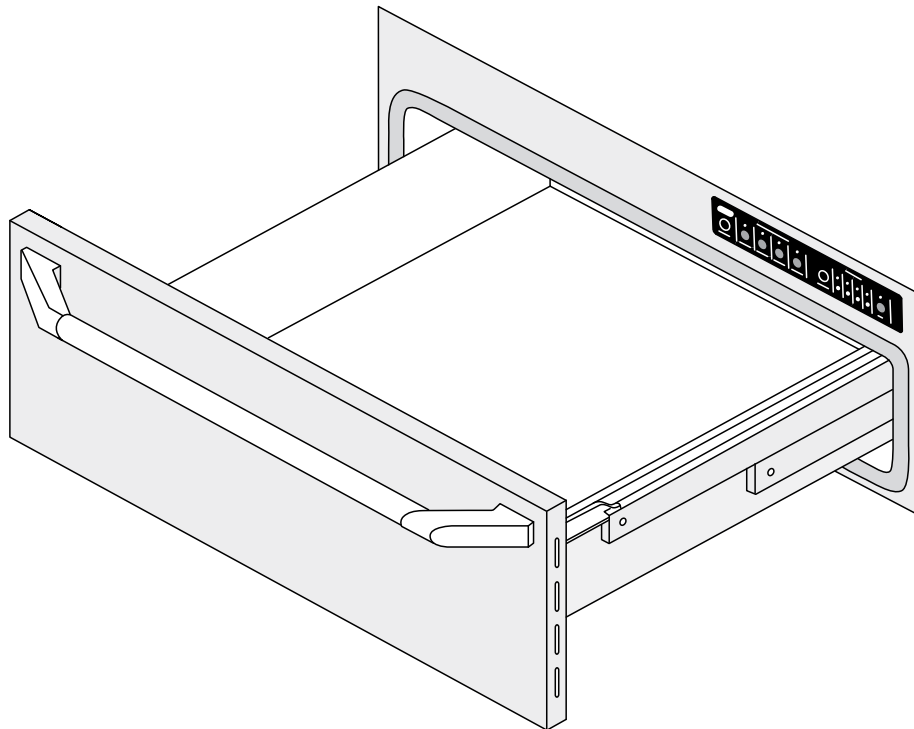

Models: EWD24, EWD27, EWD30, EWD36, IWD24,
IWD27, IWD30, MWDV27, MWDH27, MWDV30,
MWDH30, MRWD27, MRWD30, PWD27, PWD30

Table of Contents

Important Safety Instructions	1
Getting to Know Your Warming Drawer	3
Operating Instructions.....	4
Care and Cleaning	6
Before You Call for Service.....	7
Warranty and Service.....	8
Warranty Card	Back Cover



To Our Valued Customer:

Congratulations on your purchase of the very latest in Dacor® products! Our unique combination of features, style and performance make us The Life of the Kitchen™, and a great addition to your home.

In order to familiarize yourself with the controls, functions, and full potential of your new Distinctive Appliance, we suggest that you thoroughly read this use and care manual, beginning with the **Important Safety Instructions** section.

All Dacor appliances are designed and manufactured with quality and pride, while working within the framework of our company value. Should you ever experience a problem with your product, please first check the **Before You Call for Service** section of this manual for guidance. It provides useful suggestions and remedies prior to calling for service.

Valuable customer input helps us to continuously improve our products and services, so please feel free to contact our Customer Service Team for assistance with any of your product support needs.

Dacor Customer Service Team
1440 Bridge Gate Drive
Diamond Bar, CA 91765

Telephone: (800) 793-0093
Fax: (626) 403-3130
Hours of Operation: Monday through Friday
6:00 A.M. to 5:00 P.M. Pacific Time
Web Site: www.Dacor.com

Thank you for choosing Dacor for your home. We are a company built by families for families and we are dedicated to serving yours. We are confident that your new Dacor product will deliver a high level of performance and enjoyment for many years to come.

Sincerely,

Cheryl Crowe
Director, Customer Satisfaction

Important Safety Instructions

INSTALLER: LEAVE THESE INSTRUCTIONS WITH THE APPLIANCE.

CUSTOMER: READ THIS USE AND CARE MANUAL COMPLETELY BEFORE USING YOUR WARMING DRAWER. SAVE IT FOR FUTURE REFERENCE. IT CONTAINS IMPORTANT USE AND CARE INFORMATION. KEEP YOUR SALES RECEIPT OR CANCELED CHECK IN A SAFE PLACE. PROOF OF ORIGINAL PURCHASE DATE IS REQUIRED FOR WARRANTY SERVICE.

Always contact the Dacor Customer Service Team about problems or conditions that you don't understand:

Dacor Customer Service Team
1 (800) 793-0093 (U.S.A. and Canada)
Monday – Friday 6:00 A.M. to 5:00 P.M. Pacific Time
Web site: www.Dacor.com

Have the complete model and serial number for your appliance available. The numbers are found on the serial number label, located on the left of the drawer opening. Remove the drawer to access it. See page 3 for label location.

Write these numbers below for future reference.

Model Number _____

Serial Number _____

Date of Purchase _____

For service and warranty information see page 8.

Since Dacor continuously improves the quality and performance of our products, we may need to make changes to the appliance without updating this manual.

Important Information About Safety Instructions

The **Important Safety Instructions** and warnings in this manual can not cover all possible problems and conditions that can occur. Use common sense and caution when installing, maintaining or operating this appliance.

Safety Symbols and Labels

DANGER

Immediate hazards that **WILL** result in severe personal injury or death.

WARNING

Hazards or unsafe actions that **COULD** result in severe personal injury or death.

CAUTION

Hazards or unsafe actions that **COULD** result in minor personal injury or property damage.

DANGER

IMPORTANT: To avoid the possibility of explosion or fire, do not store or use flammable or explosive vapors and liquids (such as gasoline) inside or in the vicinity of this or any other appliance. Keep items that could explode, such as aerosol cans away from the appliance. Do not store flammable or explosive materials in adjacent cabinets or areas.

WARNING

NEVER use this appliance as a space heater to heat or warm the room.

WARNING

Do not use water on grease fires – smother fire or flame or use dry chemical or foam-type extinguisher.

WARNING

IMPORTANT: This appliance is equipped with a three-prong grounding electric plug for protection against possible electric shock hazards. It must be plugged into a dedicated, grounded, electrical outlet. If only a two-prong electrical outlet is available, it is the responsibility of the customer to have it replaced with a dedicated, properly grounded three-prong electrical outlet. Do not under any circumstances:

- Cut or remove the third (ground) prong from the power cord.
- Use an adapter plug.
- Use a power cord that is frayed or damaged.
- Connect the appliance to an extension cord.

NOTE: Use of a ground fault interrupter (GFI) is not recommended.

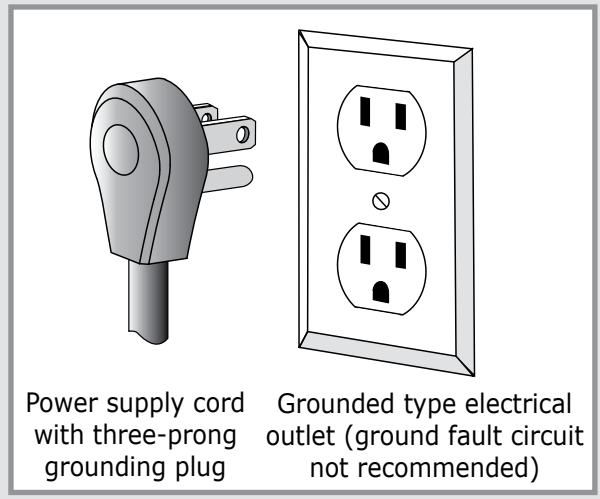

Important Safety Instructions

General Safety Precautions

To reduce risk of fire, electric shock, serious injury or death when using this appliance, follow basic precautions, including the following:

WARNING

- Read this manual completely before operating this appliance.
- Use this appliance only for its intended use as described in this manual. Use it only to warm food and heat plates and utensils. It is not designed for commercial, industrial or laboratory use.
- Do not store or install this appliance outdoors, unless otherwise noted in these instructions. Do not use this product near water, for example, near sinks, swimming pools or in a wet basement.
- If you receive a damaged product, immediately contact your dealer or builder. Do not install or operate an appliance that has been damaged or dropped.
- Make sure that this appliance has been properly installed and grounded by a qualified installer according to the accompanying installation instructions. Have the installer show you the location of the electrical outlet so that you know where to disconnect power to the appliance.
- Do not repair or replace any part of the warming drawer unless specifically recommended in the literature accompanying it. All other service should be done by a qualified technician.
- Before performing any type of service, make sure that the power plug is disconnected from the electrical outlet.
- Keep the electrical cord away from heated surfaces.
- DO NOT TOUCH ANY OF THE SURFACES INSIDE OR OUTSIDE THE WARMING DRAWER DURING OR IMMEDIATELY AFTER USE. After use, make sure these surfaces have had sufficient time to cool before touching them. Heating elements may be hot, even though they are dark in color.
- To avoid the possibility of fire or burns, do not allow clothing, pot holders, towels or rags to come into contact with any part of the warming drawer during and immediately after use. Do not wear loose or hanging apparel while using this appliance.
- To reduce the risk of fire in the warming drawer, do not overcook food. Do not leave it unattended with paper, plastic or other combustible materials inside.
- If materials inside the warming drawer should ignite, keep the drawer closed and shut off the power at the circuit breaker panel or fuse box.

WARNING

- Exercise caution when opening the drawer. Let hot air or steam escape before looking or reaching into the warming drawer.
- Use only dry pot holders when removing food and cookware from the warming drawer. Wet pot holders can cause steam burns.
- Do not put items like whole eggs, sealed containers or closed glass jars in the warming drawer. They may explode when heated, causing injury.
- Do not place more than 50 pounds in the drawer.
- Properly clean and maintain the unit regularly as instructed in this manual. Clean only those parts listed in this manual, in the manner specified.
- Do not use abrasive or caustic cleaners or detergents on this appliance. They may permanently damage the finishes. Do not use aerosol cleaners, because they may be flammable or cause corrosion of metal parts.
- Clean the appliance thoroughly before operating it for the first time.
- Make sure the warming drawer is used only by those individuals who are able to operate it properly.
- Do not tamper with the controls.
- Preheat the warming drawer before use.
- Never allow anyone, including children to sit, stand or climb on any part of the appliance, including the drawer. Doing so may cause tipping, damage, serious injury or death.
- Do not leave children alone or unattended in the area around the appliance. Do not allow children to operate it, play with the controls, pull on the handle or touch other parts.
- Do not store items of interest to children above the warming drawer. Children could be burned or injured while climbing on the appliance.

Getting to Know Your Warming Drawer

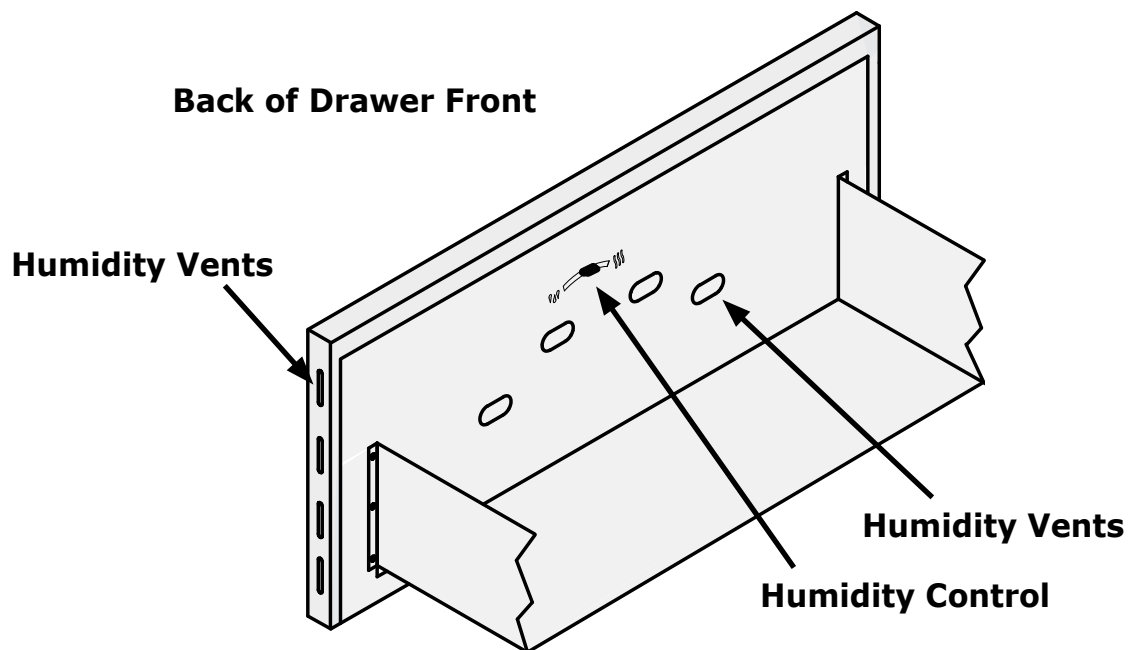
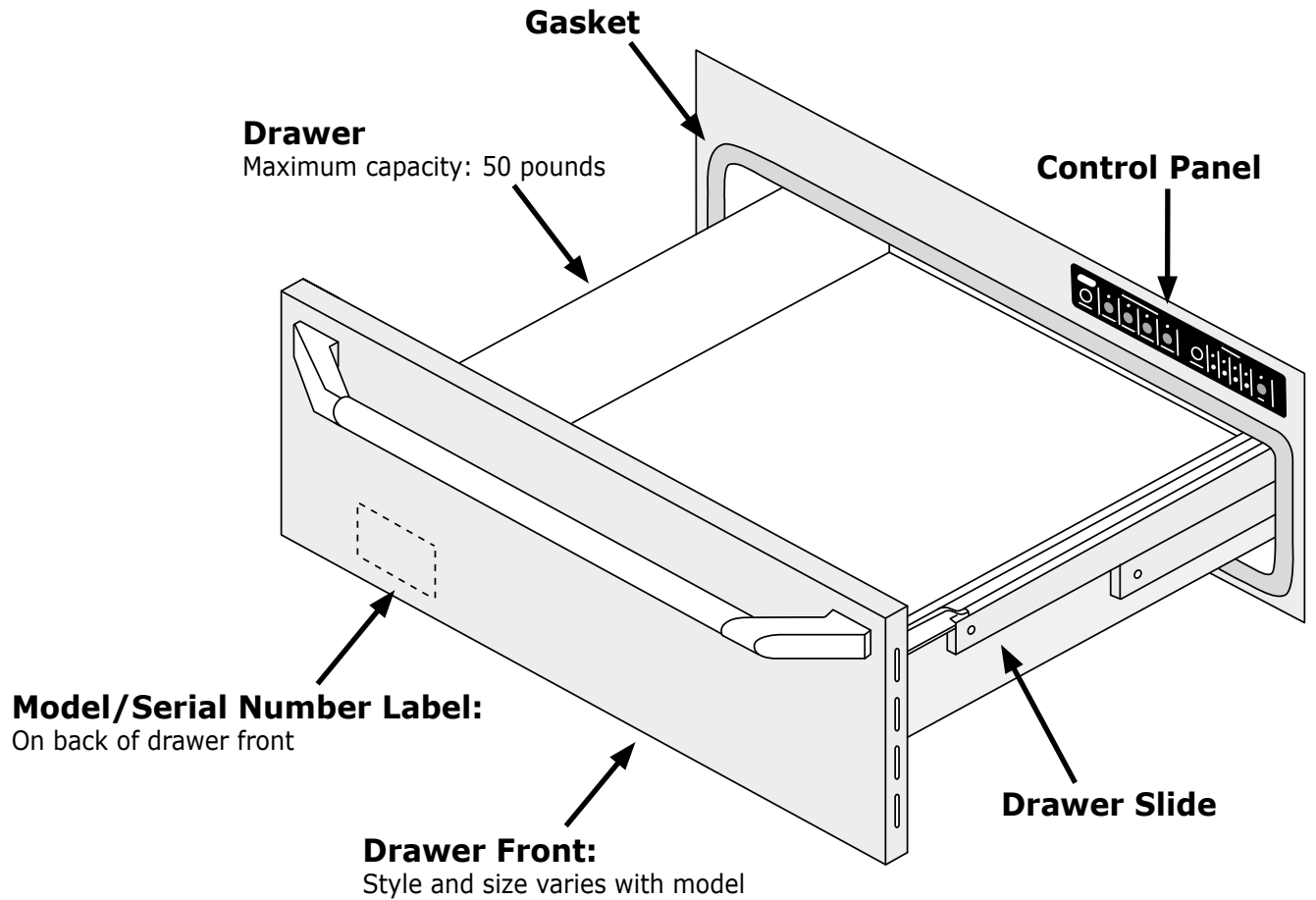

Models IWD24, IWD27 and IWD30 are not equipped with the humidity control or vents.

Operating Instructions

WARNING

- When the warming drawer is on in continuous mode (∞), it will remain on until turned off manually. To avoid a fire hazard or burns, exercise caution when operating the unit in continuous mode.
- Do not block the humidity vents on the back of the drawer front and along the left and right sides of the drawer. Excessive heat buildup can occur.
- Food safety is an important consideration when using a warming drawer. In the **PROOF** and **LOW** temperature settings, bacteria growth may occur. Use the **MED** and **HIGH** settings if holding certain foods for more than two to three hours.

Things to Know Before You Start

Preheating

- For best results, preheat your warming drawer for about 20 minutes before use. If you put hot food into a cool, confined area, any steam that is present will condense. If you preheat your warming drawer, there will be less chance of water due to condensation. Preheat times vary depending on the temperature setting.

Humidity Control

- The warming drawer has two distinct humidity modes. The "**MOIST**" setting seals the food's moisture in the warming chamber, maintaining the water content of the food. The "**CRISP**" setting allows the moisture to vent out of the sides of the warming drawer, retaining the crispness of other food types. The **MOIST • CRISP** lever opens and closes vents located on the inside of the drawer front.
- Do not block the humidity vents any time you operate your warming drawer.

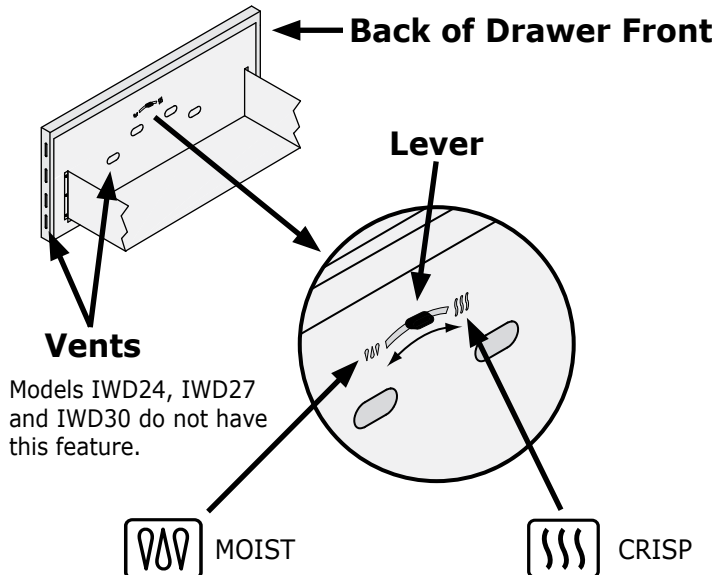

Operation

The warming drawer is equipped with four temperature settings and a timer that can be set for one, two, three or four hours. The warming drawer can also be set for continuous operation. See the table on the facing page for suggested settings for different foods.

To turn the unit on:

1. Select the humidity level. Slide the lever located on the back of the drawer face to the desired position. To increase humidity inside the drawer, slide the lever closer to the **MOIST** symbol. To decrease humidity inside the drawer, slide the lever closer to the **CRISP** symbol. The lever can also be positioned anywhere between the **MOIST** and **CRISP** settings.
2. Push the **ON/OFF** key.
3. Push the key for the desired temperature setting.

SETTING	TEMPERATURE*
PROOF	100°F (38°C)
LOW	140°F (60°C)
MED	175°F (80°C)
HIGH	200°F (93°C)

* Temperatures are approximate

4. Select the amount of time you want the warming drawer to be on: Push the **SELECT** key until the desired number of hours lights up on the control panel.



or

Push the continuous key (∞) to keep the unit on constantly. Push the **ON/OFF** key to turn the warming drawer off, when done.

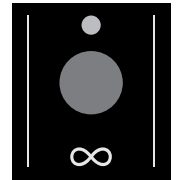

Warming Serving Containers

- To warm plates, and other serving containers:
- Place them carefully into the warming drawer and set the temperature to **PROOF** or **LOW**, depending upon your personal preference. Do not drag plates across the drawer. They may scratch the drawer surface.
- Before using any delicate dinnerware in the warming drawer, determine its maximum recommended usage temperature from the plate manufacturer. It is not necessary to preheat the warming drawer when warming serving dishes.
- You can also use plastic wrapping on plates to keep foods hot and moist.

Operating Instructions



Control Panel

Temperature and Humidity Control Setting Guidelines

FOOD ITEMS	TEMPERATURE SETTINGS	MOIST-CRISP SELECTION	COVERED/ UNCOVERED
Bacon	HIGH	Crisp	Uncovered
Beef - Rare	LOW	Moist	Covered
Bread - Hard Rolls	LOW	Crisp	Uncovered
Bread - Proofing	PROOF	Moist	Damp Towel
Casseroles	LOW	Moist	Uncovered
Coffee Cake	LOW	Moist	Uncovered
Cooked Cereals	LOW	Moist	Uncovered
Dinner	MED	Moist	Uncovered
Eggs	LOW	Moist	Covered
Enchiladas	LOW-MED	Moist	Uncovered
Fish/Seafood	LOW	Moist	Covered
Fried Food	HIGH	Crisp	Uncovered
Gravy, Cream Sauces	LOW	Moist	Covered
Ham	LOW	Moist	Covered
Hors D' Oeuvres	LOW-MED	Crisp	Uncovered
Lamb	LOW	Moist	Uncovered
Pancakes	LOW-MED	Moist	Covered
Pies - Single Crust	LOW	Moist	Uncovered
Pizza	LOW-MED	Moist	Covered
Potatoes - Baked	HIGH	Crisp	Uncovered
Poultry	HIGH	Moist	Uncovered
Vegetables	LOW	Moist	Covered
Waffles - Crisp	HIGH	Moist	Uncovered

Care and Cleaning

CAUTION

- To prevent permanent damage to the appliance surfaces, do not use abrasive cleaners or scrubbers.
- Do not allow acids (citrus juices, tomato sauces, etc.) to remain on the warming drawer's surfaces. The finish may stain.
- Do not try to remove heavy spills with a sharp object such as a knife or metal spatula. Sharp objects may scratch the surfaces.
- Always wipe stainless steel surfaces in the direction of the grain.

Control Panel

Clean the control panel with a soft cloth soaked with a solution of mild detergent and hot water. Rinse and dry with a soft cloth. Exercise caution to avoid introduction of liquids into the area behind the control panel. Do not use abrasive cleaners or scrubbers. They may permanently damage the finish or scrap off the letters and graphics.

Moist • Crisp Control

Clean the Moist • Crisp lever with a solution of mild detergent and hot water. Rinse and dry with a soft cloth.

Drawer Handle

Clean the drawer handle with a solution of mild detergent and hot water. Rinse and dry with a soft cloth.

You may also use Dacor Stainless Steel Cleaner. It is available from your Dacor dealer. Use it according to the directions on the package.

Always wipe stainless steel surfaces in the direction of the grain.

Glass Surfaces

Clean all glass surfaces with a solution of mild detergent and hot water. You may also use a mild glass cleaner to remove fingerprints or smears. Dry completely with a soft, lint-free cloth.

Brass and Chrome Surfaces

Clean brass and chrome surfaces with a solution of mild detergent and warm water. Rinse, dry and polish with a soft, lint-free cloth.

You may also use Dacor Stainless Steel Cleaner. It is available from your Dacor dealer. Use it according to the directions on the package.

Painted Surfaces

For the front face of warming drawers with a painted finish, clean with a solution of mild detergent and hot water. Rinse and dry with a soft cloth. Do not use abrasive cleaners or scrubbers. They may permanently damage the finish.

Gasket

The gasket is located around the edge of the drawer opening, below the control panel.

Gently clean the gasket with a solution of mild detergent and hot water. Rinse and dry with a soft cloth. The gasket material is soft, so be careful not to crush or damage it. Damaging the gasket will cause a poor heat seal and result in poor warming drawer performance.

Drawer Slides

The warming drawer has slides positioned on each side of the drawer. They allow the drawer to slide in and out smoothly. Remove the drawer from the slides to make cleaning easy or to access the serial number plate. The drawer slides themselves do not require maintenance.

Removing the Drawer from the Appliance

Allow the drawer to cool before attempting to remove it.

1. Pull the drawer out to the fully open position.
2. Push in on the locking tab on one side as you pull the drawer up. See the facing page.
3. When the drawer comes loose from the slide, repeat the same process on the opposite side.
4. Grip the drawer on both sides and pull it free.
5. For safety, push both drawer slides into the drawer opening.

Reinstalling The Drawer

1. Pull the drawer slides all the way out of the drawer opening.
2. Gently lower the drawer between the extended slides until it is suspended by them.
3. Slide the back of the drawer mounting brackets under the clips on the slides. See the facing page.
4. Push one side of the drawer down onto its locking tab, until the tab locks into place.
5. Repeat the same process on the opposite side.
6. Gently open and close the drawer to make sure that it is properly installed.

Care and Cleaning

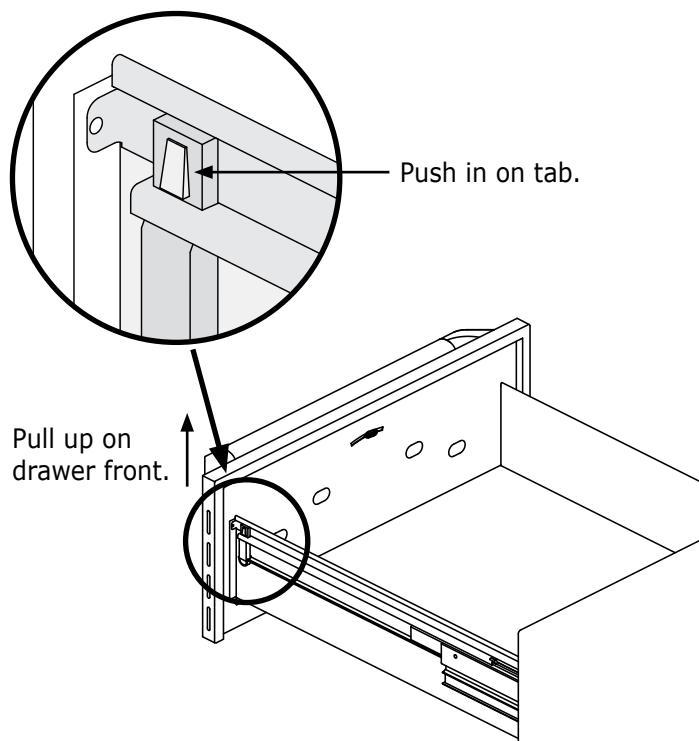

Drawer Removal

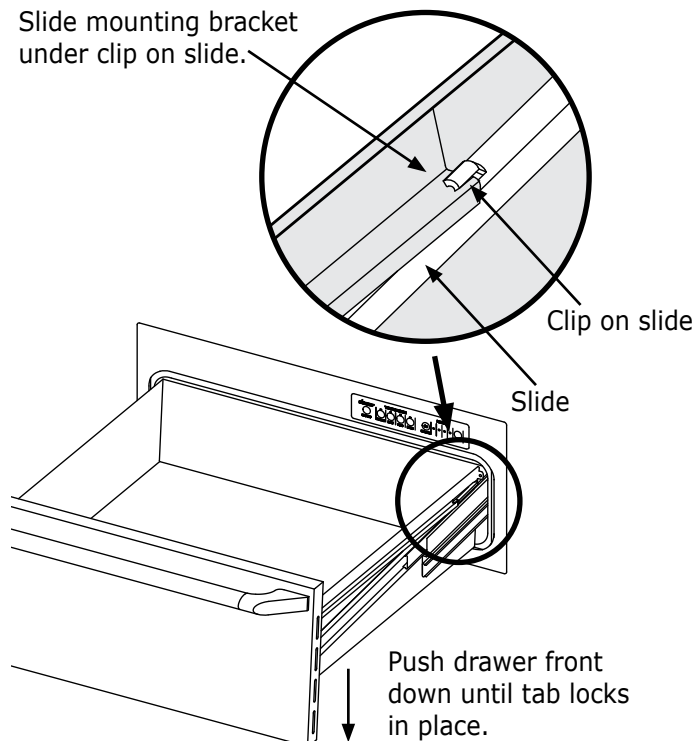

Drawer Installation

Before You Call for Service

Problem Solution Guide

PROBLEM	MAY BE CAUSED BY	WHAT TO DO
Nothing works.	Power plug disconnected.	Connect plug to a dedicated, grounded, three-prong electrical outlet.
	Timer is not set.	Select time duration according to the Operating Instructions section.
	Warming drawer is not connected to power.	Plug the warming drawer into a 120 Vac, 15 amp, dedicated electrical outlet.
	Tripped circuit breaker or blown fuse.	Check the house circuit breaker or fuse for the circuit that supplies power to the warming drawer.
Drawer does not slide smoothly or drags.	Drawer is incorrectly mounted into slide mechanism.	Remount drawer into slide, per instructions above.
	Drawer is over-loaded or the load is unbalanced.	Reduce the weight to less than 50 pounds. Redistribute drawer contents.
Excessive condensation.	Warming drawer not preheated.	Preheat the warming drawer before each use.
	Incorrect humidity control setting.	Set humidity control to CRISP to allow moisture to vent.
One or more of the indicator lights on the control panel blink on and off (one second on, one second off).	The control panel computer has detected an error: #1 - Temperature error #2 - Sensor error #3 - Key pad error #4 - Control error	Try resetting the computer. Disconnect the power cord, wait 20 seconds, then reconnect it. Check the control panel. If the indicator light still flashes, call the Dacor Customer Service Team at (800) 793-0093.

Warranty and Service

Product Maintenance

Do not perform any maintenance other than that instructed in the **Care and Cleaning** section of this manual. A qualified service technician should perform all other service.

Getting Help

Before you obtain service, please review the **Before You Call for Service section** of this manual starting on page 7. If you have performed the checks in the **Problem Solution Guide** and the problem has not yet been remedied, please visit our web site or contact our Customer Service Team for a listing of Dacor authorized service agents. Prior to requesting service, it is helpful to be familiar with the warranty terms and conditions on this page.

Contact us through our web site at:

WWW.Dacor.com

Dacor Customer Service Team:

Tel: (800) 793-0093

Fax: (626) 403-3130

Business Hours: 6:00 A.M. - 5:00 P.M. Pacific Time

You may also write us at:

Dacor Customer Service
1440 Bridge Gate Drive
Diamond Bar, CA 91765

At Dacor, we believe that our quality of service equals that of our product. Should your experience with our service network or product be different, please contact our Customer Service Team and share your encounter with us. We will do our utmost to resolve the situation for you and deliver on our Dacor promise.

If you need anything clarified, just let us know.

Warranty

What Is Covered

CERTIFICATE OF WARRANTIES: DACOR WARMING DRAWERS

WITHIN THE FIFTY STATES OF THE U.S.A., THE DISTRICT OF COLUMBIA, AND CANADA*:

FULL ONE-YEAR WARRANTY

If your DACOR product fails to function within one year of the original date of purchase, due to a defect in material or workmanship, DACOR will remedy the defect without charge to you or subsequent users. The owner must provide proof of purchase upon request, and have the appliance accessible for service.

Warranty is null and void if non-CSA approved product is transported from the U.S.

OUTSIDE THE FIFTY STATES OF THE U.S.A., THE DISTRICT OF COLUMBIA, AND CANADA:

LIMITED FIRST YEAR WARRANTY

If your DACOR product fails to function within one year of the original date of purchase, due to a defect in material or workmanship, DACOR will furnish a new part, F.O.B. factory, to replace the defective part. All delivery, installation, and labor costs are the responsibility of the purchaser. The owner must provide proof of purchase, upon request, and have the appliance accessible for service.

What Is Not Covered

- Service calls to educate the customer in the proper use and care of the product.
- Failure of the product when used for commercial, business, rental or any application other than for residential consumer use.
- Replacement of house fuses or fuse boxes, or resetting of circuit breakers.
- Damage to the product caused by accident, fire, flood or other acts of God.
- Breakage, discoloration or damage to glass, metal surfaces, plastic components, trim, paint or other cosmetic finish, caused by improper usage or care, abuse, or neglect.

THE REMEDIES PROVIDED FOR IN THE ABOVE EXPRESS WARRANTIES ARE THE SOLE AND EXCLUSIVE REMEDIES. THEREFORE, NO OTHER EXPRESS WARRANTIES ARE MADE, AND OUTSIDE THE FIFTY STATES OF THE UNITED STATES, THE DISTRICT OF COLUMBIA, AND CANADA, ALL IMPLIED WARRANTIES, INCLUDING BUT NOT LIMITED TO, ANY IMPLIED WARRANTY OF MERCHANTABILITY OR FITNESS FOR A PARTICULAR USE OR PURPOSE, ARE LIMITED IN DURATION TO ONE YEAR FROM THE DATE OF ORIGINAL PURCHASE. IN NO EVENT SHALL DACOR BE LIABLE FOR INCIDENTAL EXPENSE OR CONSEQUENTIAL DAMAGES. NO WARRANTIES, EXPRESS OR IMPLIED, ARE MADE TO ANY BUYER FOR RESALE.

Some states do not allow limitations on how long an implied warranty lasts, or do not allow the exclusion or limitation of inconsequential damages, so the above limitations or exclusions may not apply to you. This warranty gives you specific legal rights, and you may also have other rights that vary from state to state.

fold here

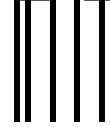

NO POSTAGE
NECESSARY
IF MAILED
IN THE
UNITED STATES

BUSINESS REPLY MAIL
FIRST-CLASS MAIL PERMIT NO. 4507 DIAMOND BAR CA

POSTAGE WILL BE PAID BY ADDRESSEE

DACOR INC.
ATTN: WARRANTY PROCESSING DEPT
1440 BRIDGE GATE DR STE 200
PO BOX 6532
DIAMOND BAR CA 91765-9861

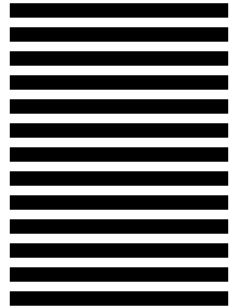



Please visit www.Dacor.com to activate your warranty online.

WARRANTY INFORMATION



IMPORTANT:

Your warranty will not be activated until you activate it online or return this form to Dacor. If you have purchased more than one Dacor product, please return all forms in one envelope or activate the warranty for each product online.

Please rest assured that under no conditions will Dacor sell your name or any of the information on this form for mailing list purposes. We are very grateful that you have chosen Dacor products for your home and do not consider the sale of such information to be a proper way of expressing our gratitude!

Owner's Name: _____
Last (Please Print or Type) First Middle

Street: _____

City: _____ State: _____ Zip: _____

Purchase Date: _____ Email: _____ Telephone: _____

Dealer: _____

City: _____ State: _____ Zip: _____

Your willingness to take a few seconds to fill in the section below will be sincerely appreciated. Thank you.

1. How were you **first** exposed to Dacor products? (Please check one only.)

- A. T.V. Cooking Show
- B. Magazine
- C. Appliance Dealer Showroom
- D. Kitchen Dealer Showroom
- E. Home Show
- F. Builder
- G. Architect/Designer
- H. Another Dacor Owner
- I. Model Home
- J. Other _____

2. Where did you buy your Dacor appliances?

- A. Appliance Dealer
- B. Kitchen Dealer
- C. Builder Supplier
- D. Builder
- E. Other _____

3. For what purpose was the product purchased?

- A. Replacement **only**
- B. Part of a Remodel
- C. New Home
- D. Other _____

4. What is your household income?

- A. Under \$75,000
- B. \$75,000 – \$100,000
- C. \$100,000 – \$150,000
- D. \$150,000 – \$200,000
- E. \$200,000 – \$250,000
- F. Over \$250,000

5. What other brands of appliances do you have in your kitchen?

- A. Cooktop _____
- B. Oven _____
- C. Dishwasher _____
- D. Refrigerator _____

6. Would you buy or recommend another Dacor product?

- Yes
- No

Comments: _____

Thank you very much for your assistance. The information you have provided will be extremely valuable in helping us plan for the future and giving you the support you deserve.

cut here