

Table of Contents

Important Safety Instructions.....	1-4
Getting To Know Your Cooktop.....	4-5
Setting Up Your Cooktop	6-7
Operating the Cooktop	8-9
Cooking Tips.....	10
Accessories and Replacement Parts.....	10
Cleaning and Maintenance.....	11-12
Before You Call for Service.....	13
Warranty & Service.....	14
Notes	15-16
Warranty Card	Back Cover



To Our Valued Customer:

Congratulations on your purchase of the very latest in Dacor® products! Our unique combination of features, style and performance make us The Life of the Kitchen™, and a great addition to your home.

In order to familiarize yourself with the controls, functions, and full potential of your new Distinctive Appliance, we suggest that you thoroughly read this use and care manual, beginning with the **Important Safety Instructions** section.

All Dacor appliances are designed and manufactured with quality and pride, while working within the framework of our company value. Should you ever experience a problem with your product, please first check the **Before You Call for Service** section of this manual for guidance. It provides useful suggestions and remedies prior to calling for service.

Valuable customer input helps us to continuously improve our products and services, so please feel free to contact our Customer Service Team for assistance with any of your product support needs.

Dacor Customer Service Team
1440 Bridge Gate Drive
Diamond Bar, CA 91765

Telephone: (800) 793-0093
Fax: (626) 403-3130
Hours of Operation: Monday through Friday
6:00 A.M. to 5:00 P.M. Pacific Time
Web Site: www.Dacor.com

Thank you for choosing Dacor for your home. We are a company built by families for families and we are dedicated to serving yours. We are confident that your new Dacor product will deliver a high level of performance and enjoyment for many years to come.

Sincerely,

Cheryl Crowe
Director, Customer Satisfaction

Important Safety Instructions

INSTALLER: Leave these instructions with the appliance.

CUSTOMER: Read this use and care manual completely before using this appliance. Save it for future reference. It contains important use and care information. Keep your sales receipt or canceled check in a safe place. Proof of original purchase date is required for warranty service.

If you have any questions, call:

Dacor Customer Service

1-800-793-0093 (U.S.A. and Canada)

Monday — Friday 6:00 A.M. to 5:00 P.M. Pacific Time

Web site: www.Dacor.com

Have the complete model and serial number identification of your cooktop ready. Record these numbers below for easy access. The numbers are found on a label on the under side of the chassis.

Model Number _____

Serial Number _____

Date of Purchase _____

For warranty and service information, see page 14.

At Dacor, we continuously improve the quality and performance of all our products. We may need to make changes to this appliance without updating these instructions.

Important Information About Safety Instructions

The *Important Safety Instructions* and warnings in this manual are not meant to cover all possible problems and situations that can occur. Use common sense and caution when installing, maintaining or operating this or any other appliance.

Always contact the Dacor Customer Service Team about appliance problems or situations that you do not understand.

Safety Symbols and Labels

DANGER

Immediate hazards that **WILL** result in severe personal injury or death.

WARNING

Hazards or unsafe practices that **COULD** result in severe personal injury or death.

CAUTION

Hazards or unsafe practices that **COULD** result in minor personal injury or property damage.

DANGER

IMPORTANT: If you smell gas:

- Do not use or light any appliance.
- Do not touch any electrical switch or use any electrical devices including the telephone in your building.
- From a neighbors phone, immediately call the gas supplier. Follow the gas supplier's instructions.
- If you cannot contact the gas supplier, call the fire department.

IMPORTANT: To avoid the possibility of explosion or fire, do not store or use combustible, flammable or explosive vapors and liquids (such as gasoline) inside or in the vicinity of this or any other appliance. Also keep items that could explode, such as aerosol cans away from the cooktop. Do not store flammable or explosive materials in adjacent cabinets or areas.

WARNING

NEVER use this appliance as a space heater to heat or warm the room. Doing so may result in carbon monoxide poisoning and overheating of the appliance.

CALIFORNIA PROPOSITION 65 WARNING

The burning of gas cooking fuel generates some by-products that are on the list of substances which are known by the State of California to cause cancer or reproductive harm. California law requires businesses to warn customers of potential exposure to such substances. To minimize exposure to these substances, always operate this unit according to the use and care manual, ensuring you provide good ventilation when cooking with gas.

WARNING

NEVER cover any slots, holes or passages on the cooktop and cooktop chassis. Doing so blocks air flow through the cooktop and may cause carbon monoxide poisoning. Aluminum foil linings may also trap heat, causing a fire hazard. Keep all slots, holes and passages clear of grease and grime.

READ AND SAVE THESE INSTRUCTIONS

Important Safety Instructions

General Safety Precautions

To reduce the risk of fire, electric shock, serious injury or death when using your cooktop, follow basic safety precautions, including the following:

WARNING

1. If you receive a damaged product, immediately contact your dealer or builder. Do not install or use a damaged appliance.
2. Make sure that the cooktop has been properly installed and grounded by a qualified installer according to the accompanying installation instructions. Have the installer show you the location of the gas shut off valve and the power cord so that you know where and how to turn off the gas supply and disconnect power to the cooktop.
3. Installations with less than 2 1/2" (64mm) from the rear of the cooktop to a combustible vertical surface must use Dacor® backguard model(s) AEB3609, AEB3612, AEB4809, AEB4812 or a non-combustible material.
4. Do not install, repair or replace any part of the cooktop unless specifically recommended in the literature accompanying it. A qualified service technician should perform all other service.
5. Before performing any type of service, make sure that the gas supply and electrical power to the cooktop is turned off.
6. Only use the cooktop for cooking tasks expected of a home appliance as outlined in this manual. This cooktop is not intended for commercial use.
7. DO NOT TOUCH THE SURFACES OF THE COOKTOP DURING OR IMMEDIATELY AFTER USE. After use, make sure these surfaces have had sufficient time to cool before touching them.
8. Make sure individuals who use the cooktop are able to operate it properly.
9. Never allow anyone, including children to sit, stand or climb on any part of the cooktop. Doing so may cause damage, serious injury or death. Do not leave children alone or unattended in the area around the cooktop. Do not allow children to play with the controls, pull on the handle or touch other parts of the cooktop.
10. Do not store items of interest to children on top of or above the cooktop. Children could be burned or injured while climbing on the appliance.
11. Do not attempt to use this appliance in the event of a power failure.
12. Do not tamper with the controls. Do not adjust or alter any part of the cooktop unless specifically instructed to do so in these instructions.
13. Do not cover the burners and grates with anything except properly selected utensils. Decorative covers may cause a fire hazard or damage to the cooktop if a burner is accidentally turned on with the cover in place.
14. Do not heat unopened food containers such as baby food jars and cans. Pressure build up may cause the container to burst and cause injury.
15. Clean the cooktop thoroughly before operating it for the first time.
16. Keep flammable items, such as paper, cardboard, plastic and cloth away from the burners and other hot surfaces. Do not allow pot holders to touch hot surfaces or gas burners.
17. Do not wear loose or hanging apparel while using the cooktop. Do not allow clothing to come into contact with the cooktop and surrounding areas during and immediately after use.
18. Do not use towels or bulky cloth as pot holders.
19. Do not hang flammable or heat sensitive objects over the cooktop.
20. If the cooktop is near a window, do not use long curtains as window treatment. The curtains could blow over the cooktop and create a fire hazard.
21. To avoid the possibility of fire, do not leave the cooktop unattended when in use.
22. Clean and maintain the cooktop regularly as instructed in this manual. Keep the entire cooktop, ventilation filters and cooktop hoods free of grease that could catch fire.

Important Safety Instructions

WARNING

23. Use cookware only for its intended purpose. Check the manufacture's recommendations before use to determine if a utensil is suitable for use on a cooktop. Certain types of glass, ceramic and earthenware are not suitable for use on a cooktop. Personal injury or damage may result from the improper use of cookware.
24. Select cookware carefully. Use utensils of the proper size, material and construction for the particular type of cooking being done. Utensils need to be large enough to contain the desired quantity of food without boil-overs or spill-overs. Choose pans with easy to hold handles that will stay cool while cooking. Do not use utensils with loose handles. Avoid using pans that are too heavy to lift safely.
25. Use extreme caution if adding water to food on a hot cooktop. The steam can cause serious burns or scalds.
26. Use only dry pot holders when removing food and cookware from the cooktop or oven. Wet pot holders can cause steam burns.
27. Make sure that all the cooktop parts are dry before lighting a burner.
28. Turn the knobs to the **OFF** position prior to removing them from the valve stems.

29. The cooktop should never be operated without the knobs and trim rings in place.

30. Non-stick coatings, when heated, can be harmful to birds. Remove birds to a separate, well-ventilated room during cooking.

31. This appliance is equipped with a three-prong grounding plug for your protection against possible electric shock hazards. It must be plugged into a dedicated, grounded receptacle. Where a standard two-prong wall receptacle is encountered, it is the personal responsibility and obligation of the customer to have it replaced with a dedicated, properly grounded three-prong wall receptacle. Do not under any circumstances, cut or remove the third (ground) prong from the power cord. Do not use an adapter plug. Do not use an extension cord. Do not use a power cord that is frayed or damaged. The use of a ground fault interrupter (GFI) is not recommended.

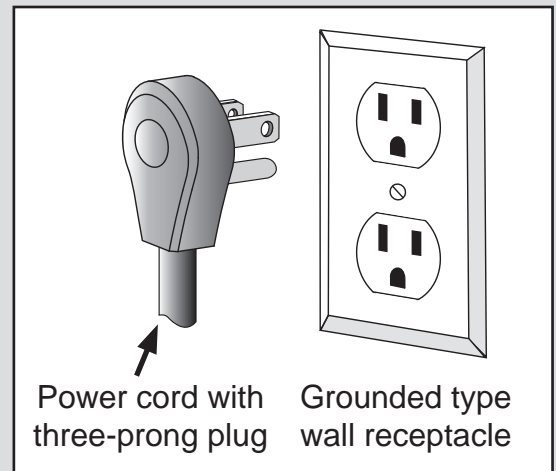

32. When deep fat frying:

- Be certain that the pan is large enough to contain the desired volume of food without overflow caused by the bubbling of the fat. Never leave a deep fat fryer unattended.
- Avoid frying moist or frost-covered foods. Foods with high water content may cause spattering or spilling of the hot fat.
- Heat fat slowly, and stir together any combination of oils and fats prior to applying heat. Utilize a deep fat frying thermometer to avoid heating the fat to temperatures above the flash point.

33. TO REDUCE THE RISK OF INJURY TO PERSONS IN THE EVENT OF A RANGE TOP GREASE FIRE:

- a. **SMOTHER FLAMES** with a close-fitting lid, cookie sheet or metal tray, then turn off the burner. **BE CAREFUL TO PREVENT BURNS.** If the flames do not go out immediately, **EVACUATE AND CALL THE FIRE DEPARTMENT.**
- b. **NEVER PICK UP A FLAMING PAN** - you may be burned.
- c. **DO NOT USE WATER**, including wet dish cloths or towels - a violent steam explosion may result.
- d. Use a fire extinguisher **ONLY** if:
 - You have a Class ABC extinguisher, and you already know how to operate it.
 - The fire is small and contained in the area where it started.
 - The fire department is being called.
 - You can fight the fire with your back to an exit.

Important Safety Instructions

⚠ CAUTION

1. Do not allow acids (citrus juices, tomato sauces, etc.) to remain on the cooktop's surfaces. The porcelain finish may stain.
2. Never use the cooktop surface as a cutting board.
3. Do not try to remove heavy spills with a sharp object such as a knife or metal spatula. Sharp objects may scratch the cooktop surfaces.
4. Do not expose the knobs or trim rings to direct flame, hot utensils or other sources of heat.

Getting to Know Your Cooktop

Model Identification

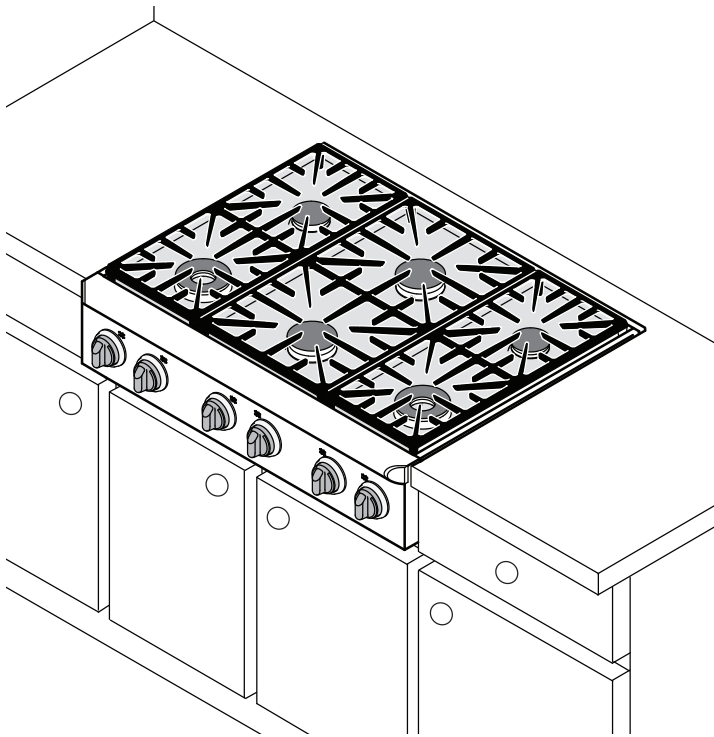

36-Inch (EG366)
(One 14-Inch Grate, Two 10-Inch Grates)

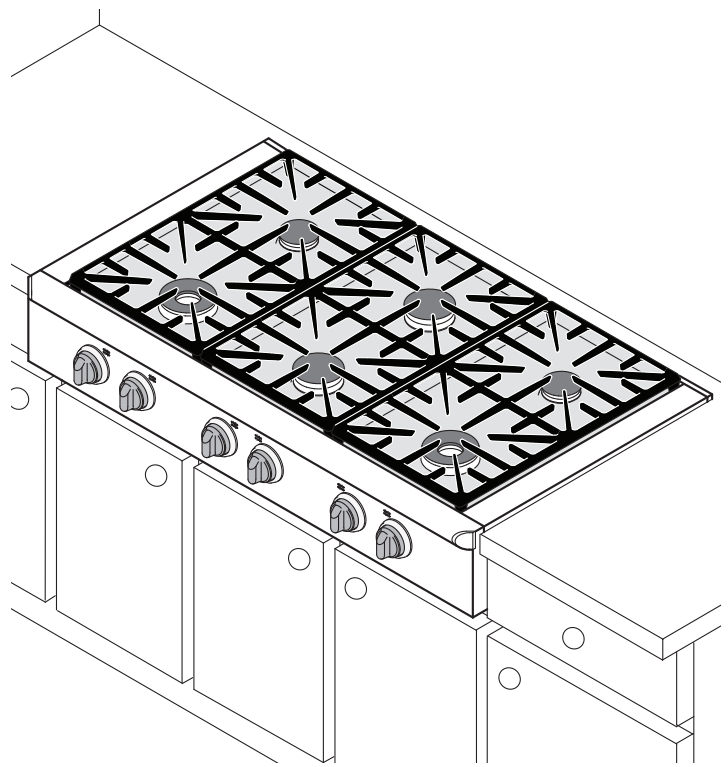

48-Inch (EG486)
(Three 14-Inch Grates)

Special Cooktop Features

Perma-Flame™: The Perma-Flame instant re-ignition feature automatically re-lights a burner quickly if it goes out. With Perma-Flame, your cooking experience is uninterrupted because the flame is re-ignited at the same level as when it went out.

Smart Flame™: Smart Flame technology reduces the temperature under the fingers of the porcelain-coated cast iron grates. Smart-Flame extends grate life and protects the finish.

SimmerSear™: Dacor's exclusive precision burner control system. It allows you to cook with a wide range of heat settings, from simmer to sear.

Getting to Know Your Cooktop

About the Cooktop

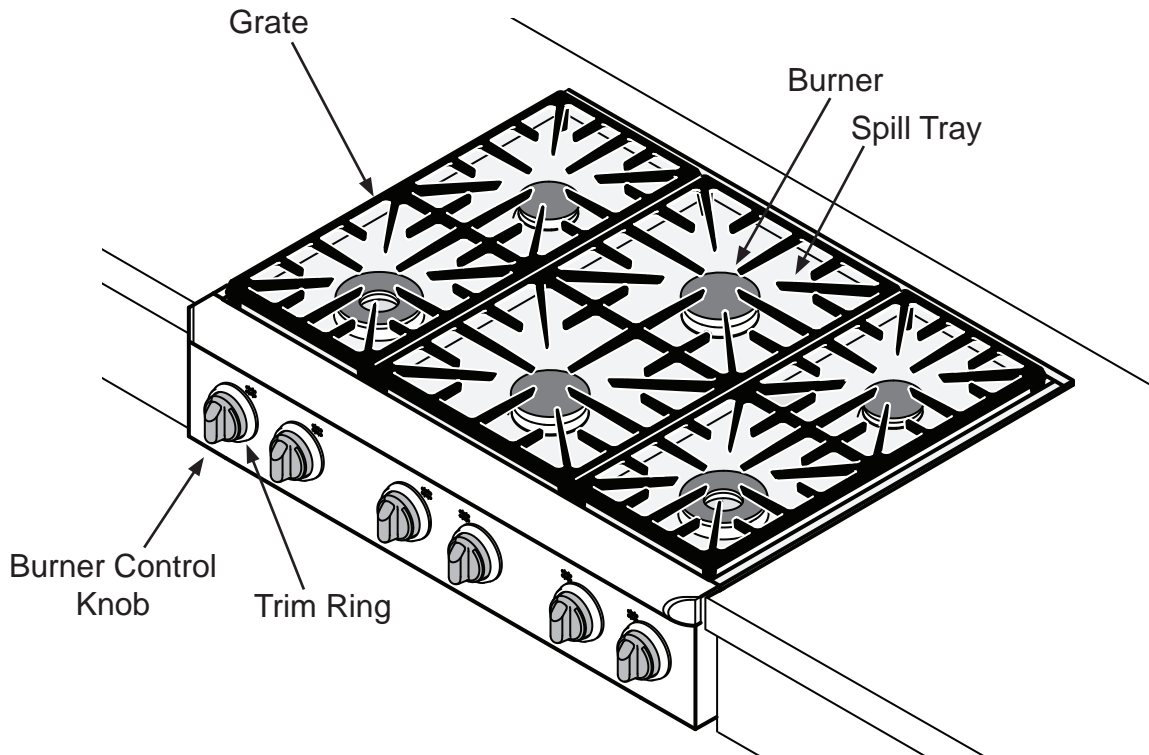

Model EG366 Shown

GRATES: The porcelain coated cast iron grates support the cooking utensils during cooking. They are removable to allow the area below and around the burners to be cleaned easily. The size and location of the grates depends on the model of the cooktop.

BURNERS: The cooktop generates a spark to light the burner when you turn the knob to **ON**. Gaskets around the underside of the burner bases prevent spilled liquids from leaking into the cooktop's internal parts.

BURNER CONTROL KNOBS: Use the knobs to turn on the burners and adjust the flame size. The matching knob illuminates when a burner is on.

TRIM RINGS: Located behind each knob. They prevent liquids from getting into the cooktop's internal parts.

SPILL TRAYS: The spill trays catch any food that falls through the cooktop grates.

Burner Locations

- A. 2000 to 8500 BTU Stack Burner
- B. 2200 to 16000 BTU Stack Burner
- C. 1000 to 18000 BTU Crown Burner

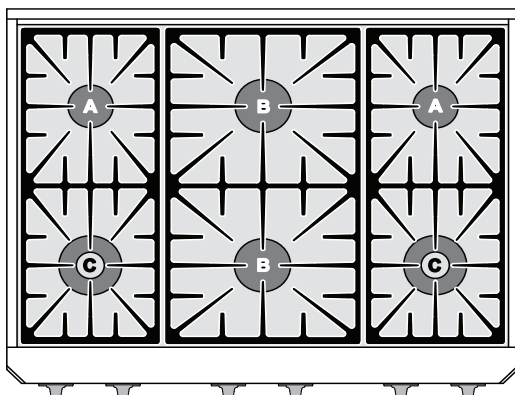

EG366

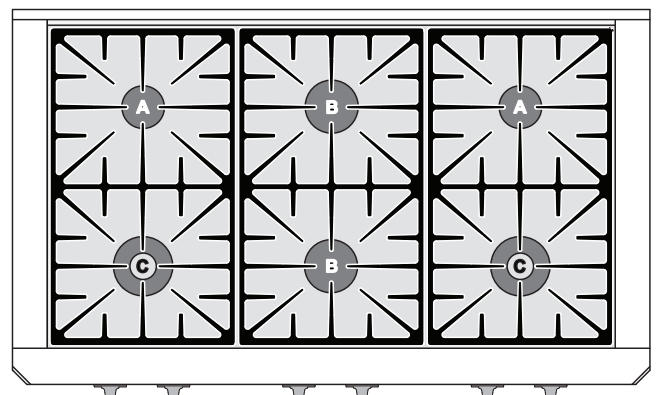

EG486

Setting Up Your Cooktop

Burner Assembly

⚠ WARNING

To avoid the chance of fire, explosion or carbon monoxide poisoning, do not attempt to use your cooktop without the burners completely and properly assembled. The burner rings spread the flame evenly around the burner cap. The burner rings must be properly seated for proper burner lighting and operation.

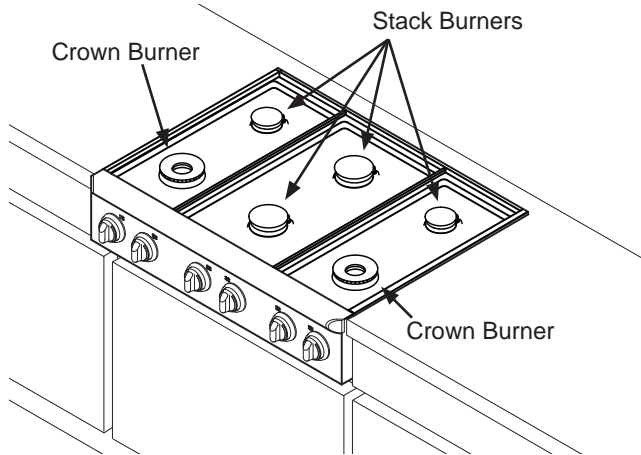

Burner Locations

Stack Burner Assembly

1. Put the burner rings on the burner bases as shown below. Match the correct sizes. The bottom of the correct size burner ring fits inside the top of the matching burner base.
2. Turn the ring until it drops into place. Twist each ring back and forth slightly to make sure it is properly seated.
3. Put the burner caps on top of the burner rings. The ridge around the bottom edge of the cap goes around the top of the burner ring.

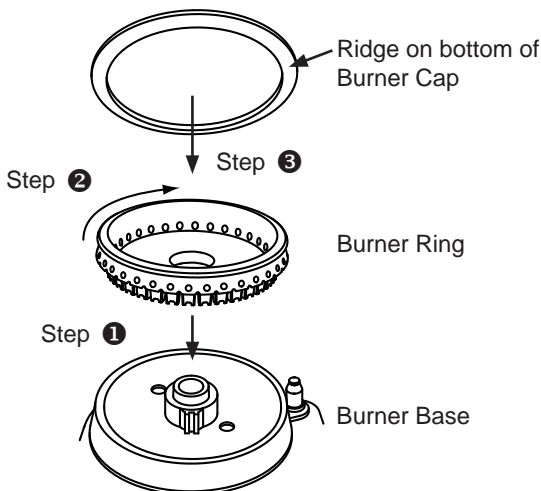

Stack Burner Assembly

Crown Burner Assembly

1. Put the burner head(s) in place as shown below. The locating tab on the burner head goes in the keyed hole as shown.
2. Put the burner ring(s) on the burner head(s) as shown below. Match the tabs on the bottom of the ring to the slots on the burner head. Twist each ring back and forth slightly to make sure it is properly seated.
3. Put the burner cap(s) on top of the burner ring(s). The ridge around the bottom edge of the cap goes around the top of the burner ring.

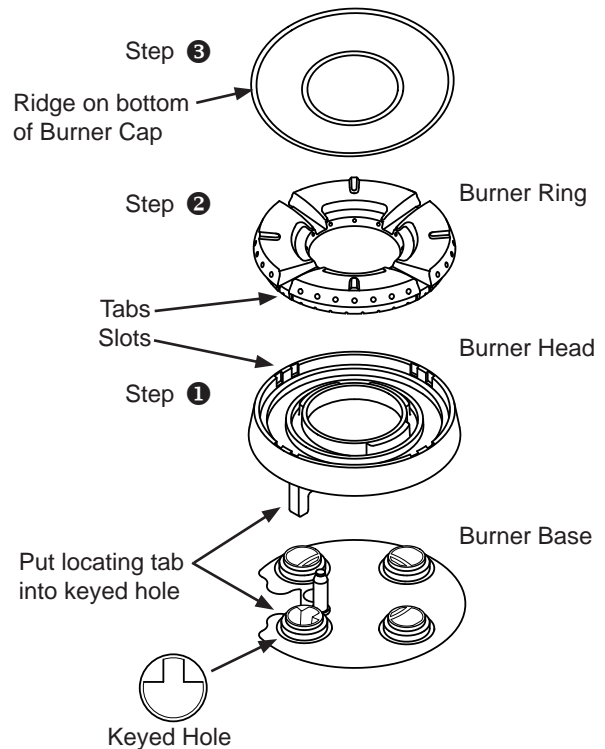

Crown Burner Assembly

Setting Up Your Cooktop

Grates

Gently set the grates on top of the spill tray. Put the legs of each grate into the corresponding dimples. On model EG366, the middle grate is larger than the other two.

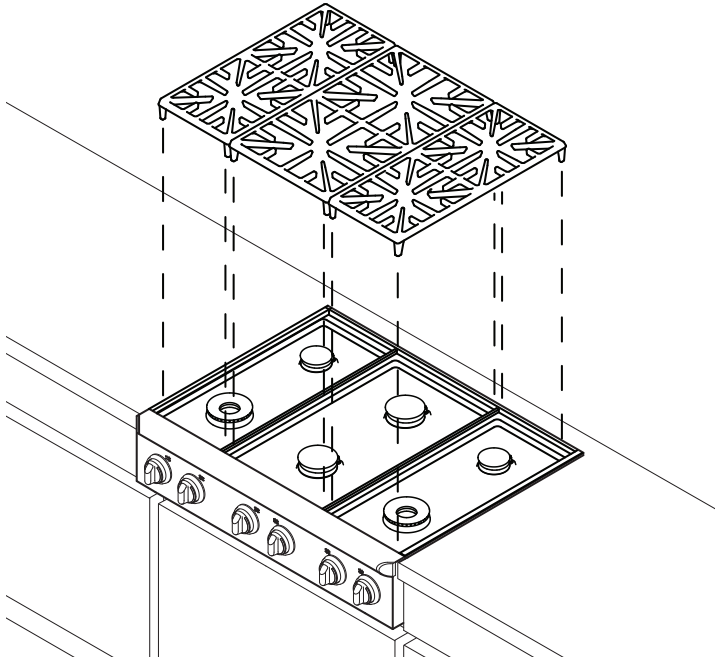

- When installing the knobs, align the “D-shaped” opening on the back of the knob with the end of the valve shaft. Carefully push the knob on until it stops.

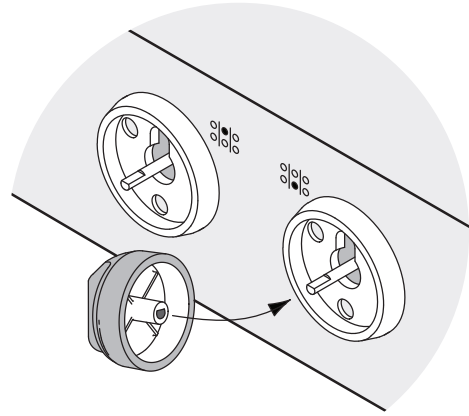

- Put the remaining knobs on the outer valve shafts.

Installing the Burner Knobs

There are two different types of knobs for the cooktop. The knobs for the center burners have the words “**MAX GRIDDLE**” on them.

- Put the knobs with “**MAX GRIDDLE**” written on them onto the inner (center burner) valve shafts.

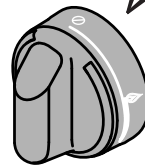
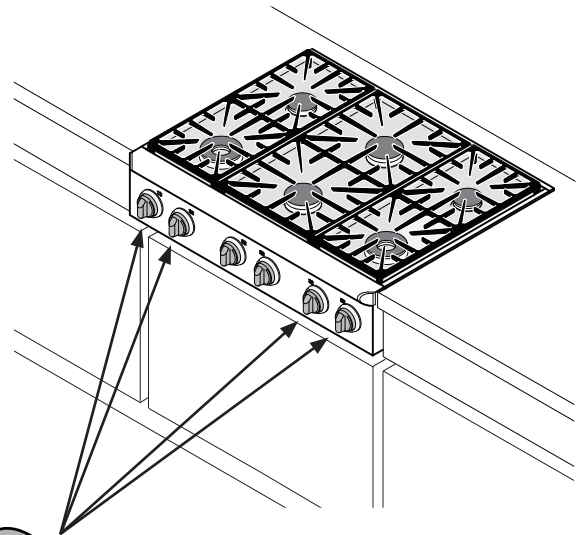

Icons on Outer Burner Knob

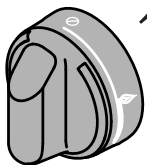
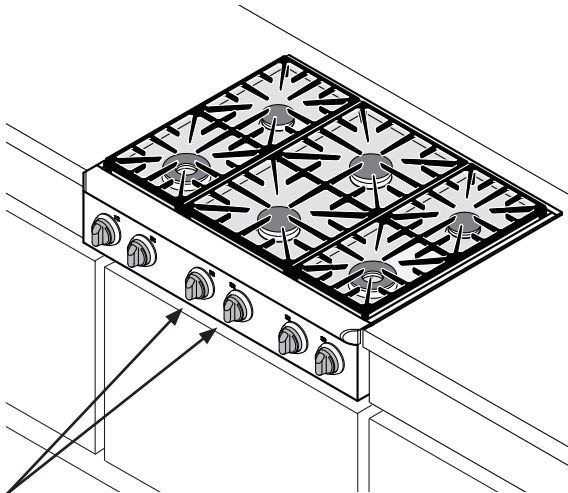

Icons on Center Burner Knobs

CAUTION

Installing the cooktop knobs in the wrong position may result in damage to the cooktop griddle. The knobs for the center burners are marked with the maximum griddle settings.

Operating the Cooktop

Selecting the Cookware

⚠ WARNING

- To avoid burns and scalding, always turn pan handles to a position where they cannot be easily hit. Also, handles should not extend over adjacent burners. Always set utensils gently onto the grates and center them so that they are well-balanced.
- Do not drag cookware across the grates. Sliding may damage the finish. Lift utensils to reposition them. Do not drop them on the grate.
- To avoid burns or fire hazard, reduce the flame level if it extends beyond the bottom of the utensil. A flame that extends up the sides of the utensil is potentially dangerous.
- Cookware with rough bottoms can cause permanent damage to the coated surfaces on the grates.

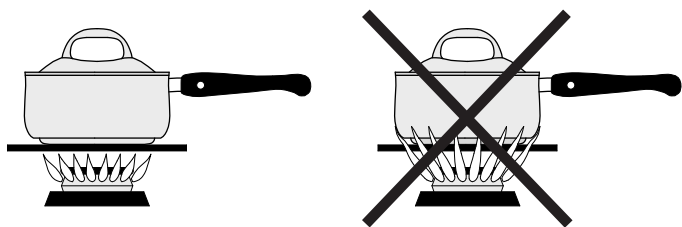

For overall safety and best cooktop performance, select the correct cooking utensil for the food being cooked. Improperly selected cooking utensils will not cook evenly or efficiently.

Use cookware that:

- Has flat, smooth bottoms.
- Is well balanced.
- Has tight fitting lids to keep heat, odors and steam in.

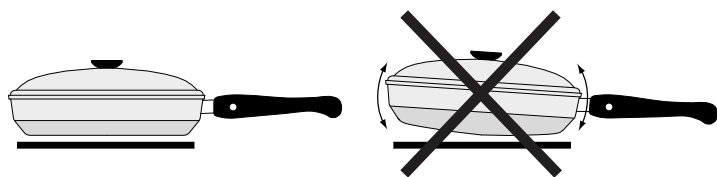

IMPORTANT:

- Avoid spills as much as possible. The porcelain surfaces of the grates, spill trays and burner caps are acid-resistant but not acid-proof. Some foods can cause permanent damage if allowed to remain on porcelain surfaces.

Lighting a burner

⚠ WARNING

- In the interest of safety, always light the burner first before putting the cooking utensil on the grate. Turn the burner knob to the off position before removing the utensil.
- Do not turn the knob past the **HIGH** position until lit. Doing so may result in a burst of flame that could cause burns or damage to the surrounding area.
- Do not touch any burner cap, burner base or igniter while the igniter is sparking. An electrical shock could result.
- If the gas does not ignite after four seconds or if the flame goes out and gas escapes, turn the knob to the **OFF** position. Open a window and allow at least five minutes for the gas to dissipate. Repeat the lighting procedure.
- Always check the position of the control knobs to make sure the cooktop is off when you are finished cooking.
- Do not operate the cooktop without all the burner components in place. If the burner ring and cap are not properly seated, the burner may not operate correctly. See page 6 for assembly instructions.
- Never light the burners with a match or other open flame.

Each burner control knob has a small diagram next to it to tell you which burner it operates.

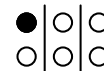

To light a burner:

1. Push in on the knob and turn it counter-clockwise to the **HIGH** position. The igniter for the burner will spark repeatedly until it lights. The spark makes a "clicking" sound. The burner should light within four seconds.

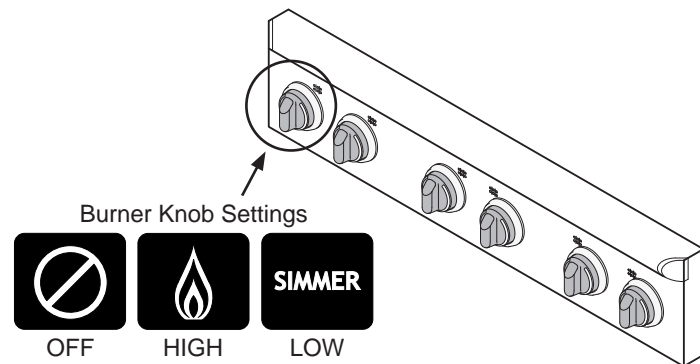

2. The flame should burn evenly around the perimeter of the burner, except underneath each grate support finger, where the flame height is reduced by Dacor's Smart-Flame™ feature. A normal flame is steady and blue in color. Foreign material in the gas line, especially in new construction, may cause an orange flame during initial operation. This will disappear with further use. Small yellow tips on the ends of the flames are normal when using LP gas.

Operating the Cooktop

Lighting a burner (cont.)

3. If a burner does not ignite, the igniter continues to spark or if the flame is not spread evenly around the burner cap, see the **Before You Call for Service** section on page 13.
4. Place the cooking utensil on the grate.
5. Adjust the flame to the level necessary to perform the desired cooking process.

IMPORTANT:

- When the cooktop is cool the igniter may continue to spark if the control knob is set to the **LOW** position. The burner will stop sparking when warm. The tendency to spark when cold can be reduced by operating the burner at a higher flame setting for about 60 seconds. After 60 seconds, lower the flame to cook. The burner will also warm up faster if a utensil is placed on the grate. The igniter will also spark automatically if the flame is distorted by a draft or by the household ventilation system. Eliminate any drafts or reduce the ventilation blower speed to reduce this type of problem.
- To keep the burners operating properly, keep the burner igniters, burner rings and burner caps clean and dry. See **Cleaning the Cooktop** starting on page 11.

Using the Griddle

1. Before using the cooktop griddle for the first time, wash it in hot, soapy water. Rinse it and allow it to dry thoroughly.
2. With all of the burners off and the cooktop cool to the touch, put the griddle over the top of the middle grate on the cooktop*. Fit the tabs that stick out of the bottom of the feet into the inside corners of the grate. When it is correctly installed, the griddle will rest securely about 1/2" above the top surface of the grate.
3. Turn the left center burner knob to the light (**HIGH**) position. Once lit, turn the knob to the **MAX GRIDDLE** position, or lower if desired. **DO NOT** keep the burner knobs higher than the **MAX GRIDDLE** setting after they are lit!
4. Repeat step 3 for the right center burner knob.

During cooking be careful with metal utensils on the surface because they can scratch the non-stick coating.

Clean the griddle after each use. See page 12 for instructions.

* **The middle grate has burners of the same size in the front and back for even heating.**

Put grease trap toward back

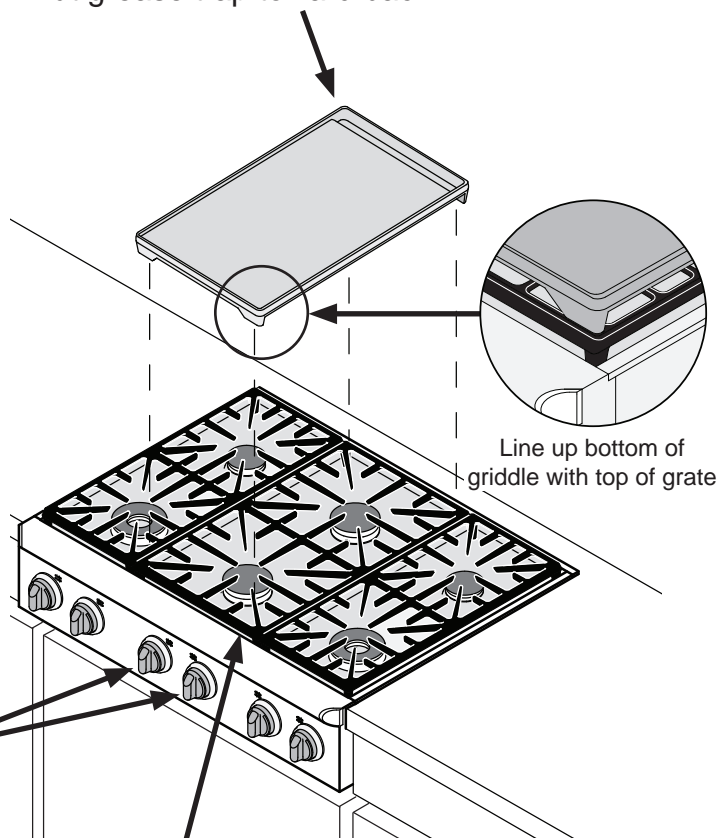

Line up bottom of griddle with top of grate

**MAX
GRIDDLE**

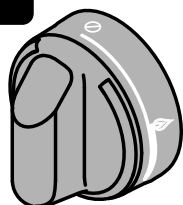

IMPORTANT!

Put the griddle over the center burners only!

Do not turn burners higher than the **MAX GRIDDLE** setting when using the griddle!

Cooking Tips

- Dacor's SimmerSear™ feature allows you precision control of the flame. The larger the burner size, the wider the range of control. See page 5 for the heat ranges of the different burners.
- Food cooks just as quickly at a gentle boil as it does at a vigorous, rolling boil. Maintaining a higher boil than necessary wastes energy and cooks moisture, food flavor and nutrients out of the food.
- Use a low or medium flame when cooking with utensils that are poor conductors of heat, such as glass, ceramic or cast iron. Reduce the flame until it covers approximately 1/3 of the utensil diameter. Doing so will ensure even heating and reduce the likelihood of burning or scorching the food.

Accessories and Replacement Parts

DESCRIPTION	DACOR PART NUMBER
Wok Ring	AWR4
Griddle	AG1424
Grill	AEGR3648
9-Inch Backguard, Model EG366	AEB3609
9-Inch Backguard, Model EG486	AEB4809
12-Inch Backguard, Model EG366	AEB3612
12-Inch Backguard, Model EG486	AEB4812
Trim Kit, Black Chrome, Model EG366 and EG486	AEGTK6BC
Trim Kit, Brass, Model EG366 and EG486	AEGTK6BR
Trim Kit, Copper, Model EG366 and EG486	AEGTK6CP
10" Grate, Model EG366 (2 used per unit)	700037
14" Grate, Model EG366 (1 used per unit) and EG486 (3 used per unit)	700038

Cleaning and Maintenance

⚠ WARNING

- Clean only the parts of the cooktop listed in this manual. Clean them only in the manner specified.
- To avoid dangerous fumes or damage to your cooktop's surfaces and accessories, use only the types of cleaning solutions specified in this manual.
- To avoid electrical shock or burns, turn off the burners and make sure that all parts are cool before cleaning. **DO NOT** turn the burners on during cleaning.
- Do not use a steam cleaner to clean the cooktop. Steam could penetrate the electrical components and cause a short circuit. After cleaning the burners, reassemble all of the burner parts before attempting to operate the cooktop.
- Always dry the cooktop parts completely before use.

⚠ CAUTION

- Do not try to remove heavy spills with a sharp object such as a knife or metal spatula. Sharp objects may scratch your cooktop's surfaces.
- To prevent damage, do not use abrasive or corrosive cleaners or applicators such as steel wool or scouring pads, on any part of the cooktop unless instructed to do so. Use only a sponge, soft cloth, fibrous or plastic brush, or nylon cleaning pad for cleaning the surfaces of your cooktop.
- Do not remove the trim rings from the cooktop. Clean only the outside edges of the trim rings. If you get moisture inside the trim rings, damage to the knob lights or other parts of the cooktop can occur.
- Do not soak the knobs in water or put them in the dishwasher.
- Installing the cooktop knobs in the wrong position may result in damage to the optional cooktop griddle. The knobs for the center burners are marked with the maximum griddle settings.

Knobs and Trim Rings

- Wash the knobs regularly with a solution of warm soapy water. Dacor recommends hand dishwashing liquid.
- Turn the knobs to the off position to remove them for cleaning or replacement.
- Grasp each knob and pull straight back, to remove.
- Clean the outside edges of the trim rings while the knobs are removed. Wipe them with a soft damp rag.
- To replace the knobs, align the "D-shaped" opening on the back of the knob with the end of the valve shaft. Carefully push the knob on until it stops. Make sure you put the two knobs with the words "**MAX GRIDDLE**" on the two valve stems closest to the center.

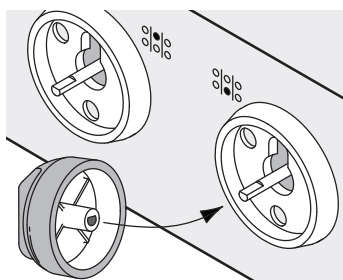

Cleaning the Cooktop

To keep the cooktop looking and operating its best, clean it after every use. Also, quickly wipe up spills that occur while cooking. Be careful not to touch any hot areas. Spills that remain on hot burner parts will be very difficult to clean, especially if allowed to burn on. Certain types of food, such as tomatoes, citrus juices, vinegar, alcohol and milk can damage the finishes if you allow them to stand for any length of time.

IMPORTANT: The cooktop is exposed to extremely high temperatures. The grates are put under a lot of stress when hot utensils are placed on them. In addition, the cooktop parts are occasionally exposed to acidic food spill-overs. These severe operating conditions, cause the porcelain enamel parts on your cooktop to undergo a change in appearance over time. If you care for and clean these parts carefully, you will slow down, but not eliminate, the aging process.

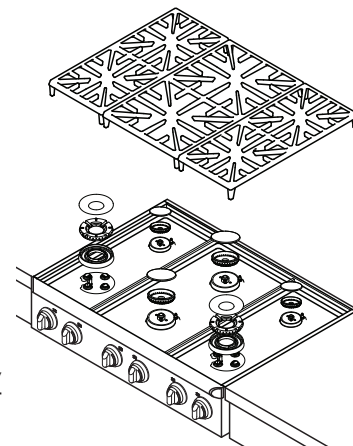

Cooktop Disassembly

When the cooktop is cool, remove the grates from the top of the cooktop.

Lift the burner caps and burner rings off of the burners. Remove the burner heads from the crown burners.

Cleaning the Grates, Spill Trays and WOK Ring

The grates, spill tray and WOK ring are coated with a porcelain finish. For everyday cleaning, use a soft cloth or non-abrasive pad with warm soapy water to clean all of the porcelain parts.

If necessary, tough stains may be removed by applying full-strength sprays such as Simple Green™, Ajax™ All-Purpose Cleaner or Formula 409™. To minimize wear, use the mildest cleaner needed to get the surface clean.

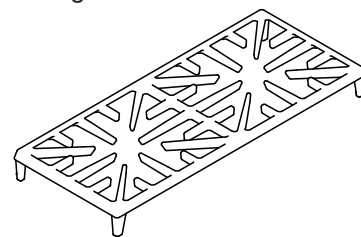

⚠ CAUTION

Do not clean the cooktop grates, burner parts or WOK ring in a dishwasher. They will be damaged.

For extremely stubborn stains, you may use a mildly abrasive cleaner or applicator, such as Soft Scrub™, Bon Ami™, S.O.S.® pads or other soap-filled steel wool pads. Use these cleaners with extreme care and only on occasion. Extensive use of these types of abrasives will eventually damage the porcelain enamel.

Cleaning and Maintenance

Cleaning the Cooktop (cont.)

Burner Components and Igniters

IMPORTANT: The igniter(s) will not work properly if the burner cap, burner ring, burner base or the igniter itself are not clean. Dirty or wet igniters may not spark at all.

After disassembling the burners, check for any dirt or grime deposited on the individual parts, including the igniters.

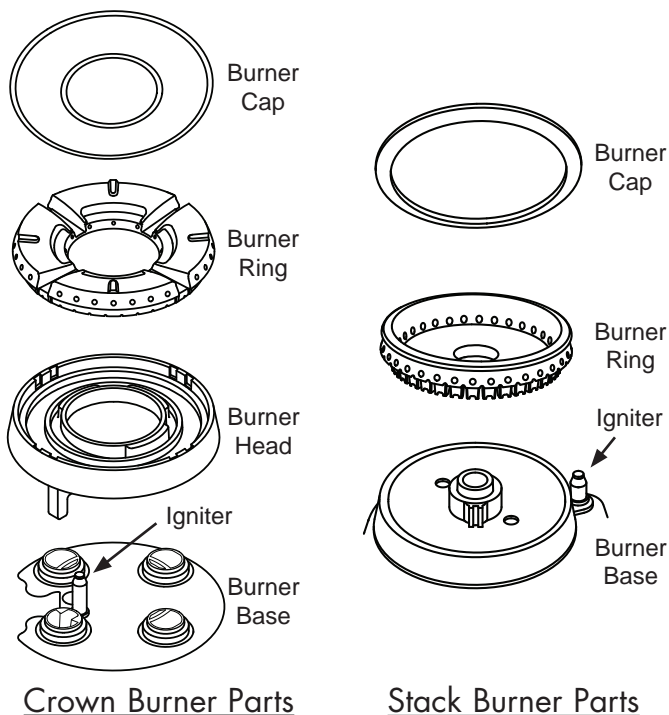

CAUTION

- Use care while cleaning the igniters. The porcelain is fragile and can crack or break.

1. Using the igniter cleaning brush that came with your cooktop, brush completely around the igniter, including over and under the edge of the metal top and porcelain base. Use care while cleaning because the porcelain is fragile and can crack or break. Do not use water to clean the igniters. If necessary, use a small amount of rubbing alcohol to help dissolve grime.
2. Examine the burner rings. Remove anything stuck in the holes with a straightened paper clip, wire or needle. Be careful not to scratch or damage the ring and cap. Do not distort the shape of the burner ring holes.
3. Clean all the burner parts, including the burner bases, with window cleaner or rubbing alcohol. Use a cleaning brush with plastic bristles or a firm tooth brush. When done, rinse the parts well with clean water. Dry all the parts thoroughly before re-assembling them.
4. Reassemble the cooktop according to the burner and grate assembly instructions starting on page 6. Test the burners after reassembling them. If the flame is uneven, be sure that the brass burner ring and porcelain

burner cap are properly positioned, then check for any remaining dirt or grime on the burner parts or igniter. If erratic clicking is still present, make sure the igniter is completely dry. If the unit still exhibits problems after drying, call your local Dacor® Authorized Service Agent.

Stainless Steel Surfaces

CAUTION

- Always wipe stainless steel (silver colored) surfaces with the grain. To prevent scratching, do not use abrasive cleaners or scrubbers on stainless steel surfaces.

Clean stainless steel surfaces with a mild solution of detergent and warm water. Rinse and dry with a soft, lint-free cloth.

You may also use Dacor Stainless Steel Cleaner on the stainless steel surfaces. Use it according to the directions on the package.

Brass, Chrome and Copper Surfaces

CAUTION

- To prevent scratching, do not use abrasive cleaners or scrubbers on metal surfaces.

Using a soft cloth, clean metal surfaces with a mild solution of detergent and warm water. Rinse and dry with a soft, lint-free cloth.

Cleaning the Griddle

Clean the griddle after each use. Wash it thoroughly in hot soapy water to avoid stains from grease build-up. The griddle is coated with a non-stick coating for easy cleaning. Warm water and liquid detergent are all that are needed for cleaning. Remove stubborn spots with a non-abrasive plastic mesh pad. To prevent scratching, do not use abrasives or abrasive cleaners. Use the soft side of a sponge to scrub it. Dry it with a lint-free cloth.

Before You Call for Service

Problem Solution Guide

PROBLEM	MAY BE CAUSED BY	WHAT TO DO
Igniters do not spark.	Cooktop not connected to electrical power.	Check to make sure power cord is connected to electrical receptacle.
	Power to electrical receptacle is off.	Turn power on at junction box. Check for tripped circuit breaker or blown fuse.
	Wet or dirty igniter.	Clean according to Cleaning and Maintenance section.
	Power outage.	Contact power company.
No flame.	Igniter not working (no clicking sound).	See igniters do not spark above.
	Wet or dirty igniter.	Clean according to Cleaning and Maintenance section.
	Gas is turned off.	Make sure the gas supply valve is in the on position.
	Gas supply interrupted.	Contact gas company.
Flame is distorted, yellow or very large.	Burner ring or burner cap is dirty or clogged.	Clean according to Cleaning and Maintenance section.
	Burner ring or burner cap not properly positioned.	Make sure burner is assembled according to the Setting Up Your Cooktop section.
	Cooktop set up to use a different type of gas (Natural or LP) or set up for different altitude.	Have a qualified service technician check to make sure that the cooktop is set up for the type of gas and the correct altitude.
	Gas regulator is not installed or faulty.	Have a qualified service technician check the gas regulator.
Igniter continues to spark (click) after flame ignites.	Burner is cold.	Burners may continue to spark for up to 60 seconds when cold and set to low. See Operating the Cooktop section for more information on how to minimize.
	Flame distorted by air draft.	Minimize any air drafts around the cooktop. Close nearby windows.
	Wet or dirty igniter.	Clean according to Cleaning and Maintenance section.
	Burner ring or burner cap is dirty.	Clean according to Cleaning and Maintenance section.
	Burner ring or burner cap not properly positioned.	Make sure burner is assembled according to the Setting Up Your Cooktop section.
Flame goes out at low setting.	Air intake holes obstructed.	Check to make sure air holes above knobs are not blocked.
	Low gas pressure.	Contact gas company.

Warranty and Service

Product Maintenance

Do not perform any maintenance other than that instructed in the **Cleaning and Maintenance** section of this manual. A qualified service technician should perform all other service.

Getting Help

Before you obtain service, please review the **Before You Call for Service** section on page 13. If you have performed the checks in the **Problem Solution Guide** and the problem has not yet been remedied, please visit our web site or contact our Customer Service Team for a listing of Dacor® authorized service agents. Prior to requesting service, it is helpful to be familiar with the warranty terms and conditions on this page.

Contact us through our web site at:

www.Dacor.com

Dacor Customer Service Team:

Tel: (800) 793-0093

Fax: (626) 403-3130

Business Hours: 6:00 A.M. - 5:00 P.M. Pacific Time

You may also write us at:

Dacor Customer Service
1440 Bridge Gate Drive
Diamond Bar, CA 91765

At Dacor, we believe that our quality of service equals that of our product. Should your experience with our service network or product be different, please contact our Customer Service Team and share your encounter with us. We will do our utmost to resolve the situation for you and deliver on our Dacor promise.

If you need anything clarified, just let us know.

What Is Covered

CERTIFICATE OF WARRANTIES: DACOR COOKTOPS

WITHIN THE FIFTY STATES OF THE U.S.A., THE DISTRICT OF COLUMBIA AND CANADA*:

FULL ONE-YEAR WARRANTY

If your DACOR product fails to function within one year of the original date of purchase, due to a defect in material or workmanship, DACOR will remedy the defect without charge to you or subsequent users. The owner must provide proof of purchase upon request, and have the appliance accessible for service.

*Warranty is null and void if non-CSA approved product is transported from the U.S.

OUTSIDE THE FIFTY STATES OF THE U.S.A., THE DISTRICT OF COLUMBIA AND CANADA:

LIMITED FIRST YEAR WARRANTY

If your DACOR product fails to function within one year of the original date of purchase, due to a defect in material or workmanship, DACOR will furnish a new part, F.O.B. factory to replace the defective part. All delivery, installation, and labor costs are the responsibility of the purchaser. The owner must provide proof of purchase, upon request, and have the appliance accessible for service.

What Is Not Covered

- Service calls to educate the customer in the proper use and care of the product.
- Failure of the product when used for commercial, business, rental or any application other than for residential consumer use.
- Replacement of house fuses or fuse boxes or resetting of circuit breakers.
- Damage to the product caused by accident, fire, flood or other acts of God.
- Breakage, discoloration or damage to glass, metal surfaces, plastic components, trim, paint or other cosmetic finish, caused by improper usage or care, abuse or neglect.

THE REMEDIES PROVIDED FOR IN THE ABOVE EXPRESS WARRANTIES ARE THE SOLE AND EXCLUSIVE REMEDIES. THEREFORE, NO OTHER EXPRESS WARRANTIES ARE MADE, AND OUTSIDE THE FIFTY STATES OF THE UNITED STATES, THE DISTRICT OF COLUMBIA AND CANADA, ALL IMPLIED WARRANTIES, INCLUDING BUT NOT LIMITED TO, ANY IMPLIED WARRANTY OF MERCHANTABILITY OR FITNESS FOR A PARTICULAR USE OR PURPOSE, ARE LIMITED IN DURATION TO ONE YEAR FROM THE DATE OF ORIGINAL PURCHASE. IN NO EVENT SHALL DACOR BE LIABLE FOR INCIDENTAL EXPENSE OR CONSEQUENTIAL DAMAGES. NO WARRANTIES, EXPRESS OR IMPLIED, ARE MADE TO ANY BUYER FOR RESALE.

Some states do not allow limitations on how long an implied warranty lasts, or do not allow the exclusion or limitation of inconsequential damages, so the above limitations or exclusions may not apply to you. This warranty gives you specific legal rights, and you may also have other rights that vary from state to state.

Notes

Notes

fold here



NO POSTAGE
NECESSARY
IF MAILED
IN THE
UNITED STATES

BUSINESS REPLY MAIL
FIRST-CLASS MAIL PERMIT NO. 4507 DIAMOND BAR CA

POSTAGE WILL BE PAID BY ADDRESSEE

DACOR INC.
ATTN: WARRANTY PROCESSING DEPT
1440 BRIDGE GATE DR STE 200
PO BOX 6532
DIAMOND BAR CA 91765-9861

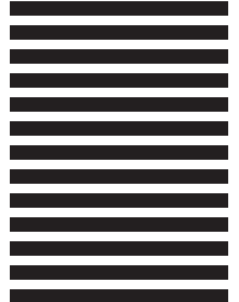

WARRANTY INFORMATION



IMPORTANT:

Your warranty will not be activated until you activate it online or return this form to Dacor. If you have purchased more than one Dacor product, please return all forms in one envelope or activate the warranty for each product online.

Please rest assured that under no conditions will Dacor sell your name or any of the information on this form for mailing list purposes. We are very grateful that you have chosen Dacor products for your home and do not consider the sale of such information to be a proper way of expressing our gratitude!

Owner's Name: _____
Last (Please Print or Type) First Middle

Street: _____

City: _____ State: _____ Zip: _____

Purchase Date: _____ Email: _____ Telephone: _____

Dealer: _____

City: _____ State: _____ Zip: _____

Your willingness to take a few seconds to fill in the section below will be sincerely appreciated. Thank you.

1. How were you **first** exposed to Dacor products? (Please check one only.)

- | | |
|-------------------------------------------------------|-------------------------------------------------|
| <input type="checkbox"/> A. T.V. Cooking Show | <input type="checkbox"/> F. Builder |
| <input type="checkbox"/> B. Magazine | <input type="checkbox"/> G. Architect/Designer |
| <input type="checkbox"/> C. Appliance Dealer Showroom | <input type="checkbox"/> H. Another Dacor Owner |
| <input type="checkbox"/> D. Kitchen Dealer Showroom | <input type="checkbox"/> I. Model Home |
| <input type="checkbox"/> E. Home Show | <input type="checkbox"/> J. Other _____ |

2. Where did you buy your Dacor appliances?

- | | |
|----------------------------------------------|-----------------------------------------|
| <input type="checkbox"/> A. Appliance Dealer | <input type="checkbox"/> D. Builder |
| <input type="checkbox"/> B. Kitchen Dealer | <input type="checkbox"/> E. Other _____ |
| <input type="checkbox"/> C. Builder Supplier | |

3. For what purpose was the product purchased?

- | | |
|-----------------------------------------------------|-----------------------------------------|
| <input type="checkbox"/> A. Replacement only | <input type="checkbox"/> C. New Home |
| <input type="checkbox"/> B. Part of a Remodel | <input type="checkbox"/> D. Other _____ |

4. What is your household income?

- | | |
|---------------------------------------------------|---------------------------------------------------|
| <input type="checkbox"/> A. Under \$75,000 | <input type="checkbox"/> D. \$150,000 – \$200,000 |
| <input type="checkbox"/> B. \$75,000 – \$100,000 | <input type="checkbox"/> E. \$200,000 – \$250,000 |
| <input type="checkbox"/> C. \$100,000 – \$150,000 | <input type="checkbox"/> F. Over \$250,000 |

5. What other brands of appliances do you have in your kitchen?

- | | |
|------------------|-----------------------|
| A. Cooktop _____ | C. Dishwasher _____ |
| B. Oven _____ | D. Refrigerator _____ |

6. Would you buy or recommend another Dacor product?

- Yes No

Comments: _____

Thank you very much for your assistance. The information you have provided will be extremely valuable in helping us plan for the future and giving you the support you deserve.

