

Installation instructions and user guide

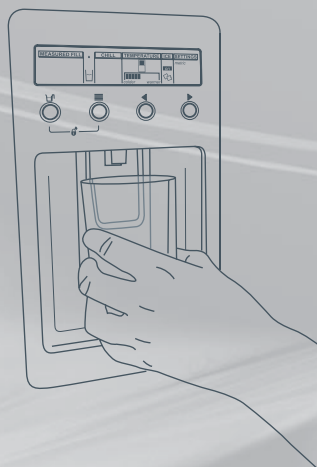

Ice & Water refrigerator

E402B, E442B, E522B, RF610A, RF540A, RF201A models

NZ AU GB AE HK SG IE

Introduction	2
Safety and warnings	3
Installation instructions	5
Before you start using your Ice & Water refrigerator	15
All about the display	16
Using your water dispenser	18
Using your ice maker	19
Using the display options	21
Measured Fill	21
Freezer Chill and Bottle Chill	22
The temperature of your refrigerator and freezer	23
Settings/User warnings	24
<i>Active Smart™</i> special features	26
Water filter	28
Measured Fill Calibration	30
<i>Active Smart™</i> maintenance	31
Cleaning and caring for your refrigerator	32
On vacation/holiday	35
Refrigerator sounds	36
Storing food in your refrigerator	37
Storing food in your freezer	38
Troubleshooting	40
Manufacturers warranty	44
Customer care	45
Filter performance data sheet	47

Important!
SAVE THESE INSTRUCTIONS

The models shown in this user guide may not be available in all markets and are subject to change at any time. For current details about model and specification availability in your country, please go to our website www.fisherpaykel.com or contact your local Fisher & Paykel dealer.

2 Introduction

Thank you for buying a Fisher & Paykel *Active Smart*™ refrigerator with automatic ice dispensing and chilled water through the door.

At Fisher & Paykel we are very proud of this refrigerator. We feel we have achieved water dispensing through the door without compromising storage space or access in the refrigerator. During our testing we have enjoyed the health benefits of having cool filtered water so accessible, while minimising the number of door openings.

Thousands of hours of food care research and 70 years of refrigeration experience has been programmed into your refrigerator to give you the best possible performance.

We hope you enjoy your new refrigerator.

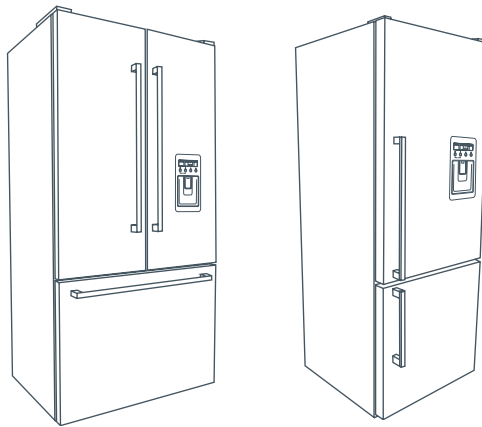

Fig.1 Ice & Water Refrigerators

Important!

It is important that this User Guide should be retained with your Ice & Water refrigerator for future reference. Should the appliance be sold or transferred to another owner, please ensure that the User Guide is left with the appliance. This will ensure that the new owner can familiarise themselves with the information and warnings contained within the Guide.

⚠ WARNING!**Electric Shock Hazard**

Read and follow the SAFETY AND WARNINGS outlined in this User Guide before operating this appliance.

Failure to do so can result in death, electric shock, fire or injury to persons.

Use this appliance only for its intended purpose as described in this User Guide.

Important safety precautions

Warning

When using this appliance always exercise basic safety precautions including the following:

Danger

- *This appliance is not intended for use by children or infirmed persons without supervision. This is especially important when using the freezer drawer compartment. Young children should be supervised to ensure they do not play with the appliance.*
- *Risk of child entrapment. Before you throw away your old refrigerator or freezer:*
 - *Take off the doors*
 - *Leave the shelves in place so that children may not easily climb inside.*

Disposal

- *Extreme care must be taken when disposing of your old appliance to avoid hazards. The refrigerant gas must be safely removed and for the safety of young children, remove doors.*
- *Your Fisher & Paykel Appliances Authorised Service Centre will be able to give advice on environmentally friendly methods of disposing of your old refrigerator or freezer.*

Electrical

- *This appliance must be properly installed in accordance with the installation instructions before it is used.*
- *Never unplug your refrigerator or freezer by pulling on the power cord.*
- *Always grip the plug firmly and pull straight out from the outlet.*
- *Do not plug in any other appliance at the same power point as your refrigerator or freezer or use extension cords or double adapters.*
- *Repair or replace immediately all electric service cords that have become frayed or otherwise damaged. Do not use a cord that shows cracks or abrasion along its length or at either the plug or appliance end.*

If the power supply cord is damaged, it must only be replaced by your Fisher & Paykel Appliances Authorised Service Centre because special purpose tools are required.

Safety and warnings

- *When moving your appliance away from the wall, be careful not to roll over or damage the power cord.*
- *Unplug your refrigerator or freezer before cleaning or replacing the lightbulb.*

Storing food and drinks

- *Never store volatile or flammable materials in your refrigerator or freezer as they may explode.*
- *Never freeze liquids in glass containers. Liquid expands during freezing, which may cause the container to explode.*
- *Never freeze carbonated drinks. They may explode.*
- *Do not consume food if it is too cold. Food removed from the freezer compartment may be cold enough to cause damage when brought into contact with bare skin eg frozen ice cubes.*

Power failure – food safety

- *Do not refreeze frozen foods that have thawed completely. Follow the recommendations below if you discover food in your freezer has thawed:*
 - 1) *Ice crystals still visible – food may be refrozen but should be stored for a shorter period than recommended.*
 - 2) *Thawed but refrigerator cold – refreezing generally not recommended. Fruits and some cooked food can be refrozen but use as soon as possible. Meat, fish, poultry – use immediately or cook then refreeze. Vegetables – discard as they usually go limp and soggy.*
 - 3) *Thawed but warmer than 4 °C (38 °F). Red meat can be cooked immediately and refrozen but use as soon as possible. Discard all other frozen foods.*
- *Do not refreeze frozen foods that have thawed completely. The food may be dangerous to eat.*

Cleaning

- *Many commercially available cleaning products contain solvents which may attack plastic components of your refrigerator or freezer and cause them to crack. Please refer to the cleaning care section of this booklet for further advice.*

Contents of filter kit

- 1 4 m (13 ft) white 6 mm (¼") tubing
- 2 1 x 200 mm (8") blue tubing
- 3 1 x pressure reducing valve (PRV)
- 4 1 x double sided foam
- 5 2 x locking keys
- 6 1 x water filter cartridge and head
- 7 1 x tap connection – 15 mm (½") BSP

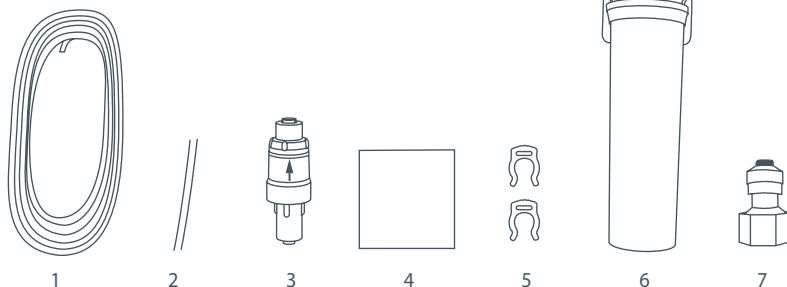

Fig.2 Water connection kit

Important!

- *It is imperative the pressure reducing valve (PRV) is fitted prior to the filter. This valve ensures the water will not flow back into the mains from the refrigerator water system. If the PRV is not fitted to the connection line your Ice & Water refrigerator features may not function in some circumstances.*
- *It is recommended that an authorised plumber in your state or town is used to install the water connection.*
- *The new tubings supplied with the machine are to be used, old tubings should not be used.*

Installation precautions/warning

- **DO NOT use with water that is microbiologically unsafe or of unknown quality without adequate disinfection before or after the system.**
- **WARNING** – connect to potable water supply only.
- **DO NOT install on line pressure above 900 kPa (130 psi) or below 150 kPa (22 psi).**
- **DO NOT use on hot water supply (38°C [100°F max.]).**
- **DO NOT install near electrical wires or water pipes that will be in the path of drilling when selecting the location of filter system.**
- **DO NOT mount filter in such a position so that it will be struck by other items, such as wastebaskets, etc.**
- **DO NOT install the filter in direct sunlight as prolonged exposure to light can weaken plastic components.**
- **DO NOT install in a location that is susceptible to freezing temperatures as damage to the housing could occur.**
- **DO NOT screw filter to fridge.**
- **AVOID contamination of pipes during installation.**

6 Installation instructions

Installation instructions:

- 1 Ensure that refrigerator is not plugged into a power supply.
- 2 Locate isolation tap for water connection – cold water feed only (dishwasher or sink mixer taps) – if you can't find the connection tap, contact an authorised plumber in your state or town to fit your water connection.
- 3 Connect the 200 mm (8") blue tubing to the outlet of the PRV (blue collet) and the inlet connection of the water filter cartridge as shown in Diagram 1. Gently pull on both ends to ensure it is locked.
- 4 Connect the white 6 mm (¼") tubing to the outlet of the water filter cartridge as shown in Diagram 2. Gently pull to ensure it is locked.
- 5 Measure the required length of tubing to run from the PRV to the water connection point.
- 6 Cut the tubing making sure the ends are square and clean.
- 7 Connect the tubing to the tap connection and the base of the PRV (white collet) and then to the tap as shown in Diagram 3. Please note that the tap connection supplied should fit most installation situations. If your tap requires a different fitting, please contact an authorised plumber in your state or town to purchase the correct fitting.
- 8 Connect one locking key to each side of the water filter cartridge in between the cartridge and the locking collet as shown in Diagram 4.
- 9 To flush the water filter and check for leaks, aim the end of the tubing into a bucket, turn isolating tap on and run at least 3 litres (3 qt) of water through. Once complete, turn isolating tap off.
- 10 Locate desired position for water filter noting carefully the following points:
 - It is recommended to fit the filter in a vertical orientation with the water filter head at the top. This will minimise water leakage when replacing cartridge.
 - Ensure the filter is in a convenient location to access every 6 months for replacement. We suggest that this location is beside the water filter supply tap in the cupboard beside the refrigerator.
 - A minimum clearance of 64 mm (2 ½") from the bottom of the filter cartridge is required to perform cartridge removal.
 - Do not screw filter to fridge.

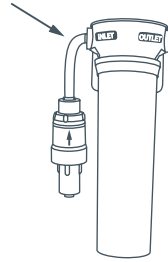

Diagram 1
Fig.3 PRV connection

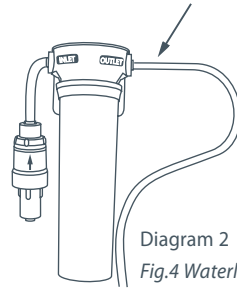

Diagram 2
Fig.4 Waterline connection

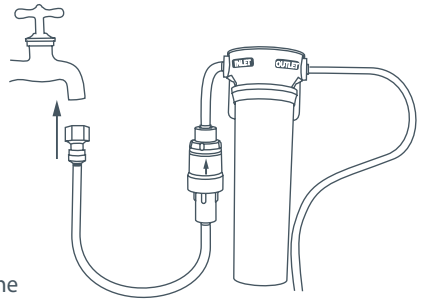

Diagram 3
Fig.5 Tap connection

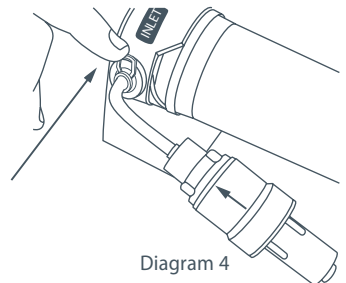

Diagram 4
Fig.6 Locking key

- 11 Attach double sided foam to the back of the water filter head as shown in Diagram 5. Write the date to be replaced on the filter (date installed + 6 months). Remove double sided foam backing and attach filter to the desired position as located in step 10 (refer to previous page).
- 12 Run the 6 mm (¼") tubing to back of the fridge ensuring there is enough tubing to pull out the refrigerator for service.
- 13 Connect tubing into the water (solenoid) valve located on the right hand side of the unit (compressor) compartment as shown in Diagram 7. Beware of hot pipes.
- 14 Pull gently on tubing to ensure it is locked in as shown in Diagram 8.
- 15 The completed installation should look like Diagram 9 on page 8.

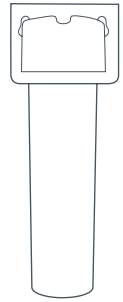

Diagram 5

Fig.7 Double sided foam attachment

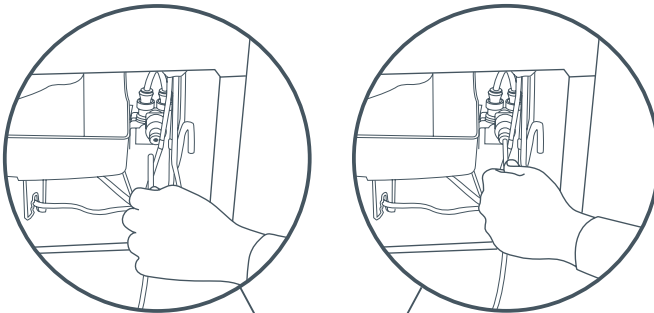

Diagram 7

Diagram 8

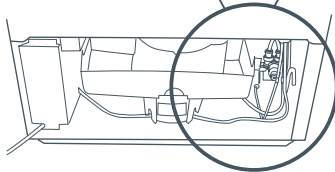







Diagram 6

Fig.8 Waterline connection to refrigerator

- 16 Turn isolating tap on and check that all connections are dry and free of drips. If not, please alert the plumber.
- 17 Coil water line tubing behind the fridge. Push your refrigerator into place being careful not to kink or squash the water line running into the water (solenoid) valve.
- 18 Read pages 9 – 14 carefully, and then turn refrigerator on.
- 19 The first time you require water out of the dispenser, there will be a delay while the water reservoir fills up. As this is happening, the  symbol will flash. Once the reservoir is full, this symbol will stop flashing.
- 20 Run a further 3 litres (3 qt) through the system, stopping intermittently to ensure the reservoir is flushed out. Failure to do this will result in excessive dripping from your dispenser.
- 21 Press  until the Ice menu is highlighted then press  to turn on the ice maker. Press   together to force a cycle. The ice tray will flip. Force another cycle. The ice tray will flip and spill the water into the ice bin. Empty water and replace bin.
- 22 You are now ready to enjoy chilled water and ice dispensing from your *Active Smart™* refrigerator. Please note that once installation is complete a few drips may appear out of the dispenser over the next few days as the remaining trapped air is cleared.

Important!

- *All connections must be checked for leaks.*
- *If unsure of connection process and/or leaks then contact your local plumber to install and check the system for you.*
- *Ensure white 6 mm (¼") tubing is routed away from sharp objects, sharp corners (beware of kinking tube as this will stop water flow), clear of the refrigerator unit compartment and not in a location where it can be squashed.*
- *Ensure all push-fit connections are firmly pushed into place. The tube should push in 20 mm (¾") before reaching the stop.*
- *If tubing is removed at any point, re-cut the end and re-insert. Tubing must be fully inserted to avoid leaks.*
- *To remove tube from connection points, turn off the isolating tap, push in the collet and gently pull tubing at the same time.*

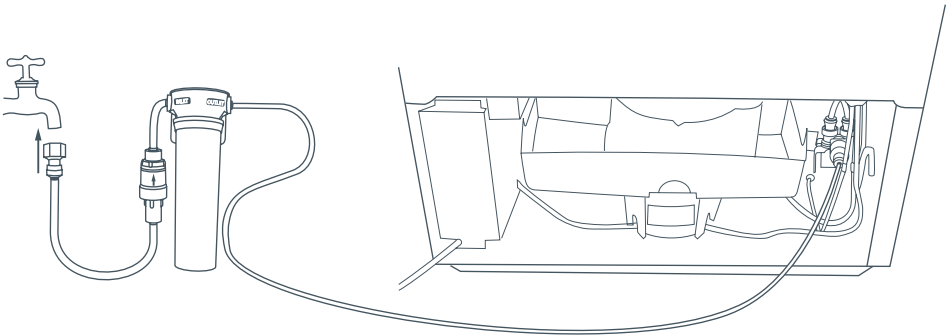

Fig.9 Connection to water supply

Diagram 9

System tested and certified by NSF International against NSF/ANSI Standard 53 for the reduction of Asbestos, Atrazine, Benzene, Cyst, Carbofuran, Lead, Lindane, Mercury, P-Dichlorobenzene, Toxaphene & Turbidity; against Standard NSF/ANSI 42 for the reduction of Chlorine Taste and Odour and Nominal Particulate Class I to a capacity of 2,838 Litres (750 gallons).

⚠ WARNING!**Electric Shock Hazard**

Read and follow the **SAFETY AND WARNINGS** outlined in this User Guide before operating this appliance, pages 3 – 4.

Failure to do so can result in death, electric shock, fire or injury to persons.

Please follow the steps for installation to ensure your appliance operates correctly.

1. Power

- The appliance must be installed so the plug is accessible.
- To ensure that the appliance is not accidentally switched off, connect your refrigerator or freezer to its own power point. Do not plug in any other appliance at this power point or use extension cords and double adaptors, as the combined weight of both power cords can pull the double adaptor from a wall outlet socket.
- For power requirements, refer to the information on the serial plate located at the front bottom right-hand side of the refrigerator when the door is open.
- It is essential that the appliance be properly grounded (earthed).

2. Location

- Your refrigerator or freezer should not be located in direct sunlight or next to any heat generating appliance such as a cooktop, oven or dishwasher.

10 Installation instructions

E402B, E442B, E522B

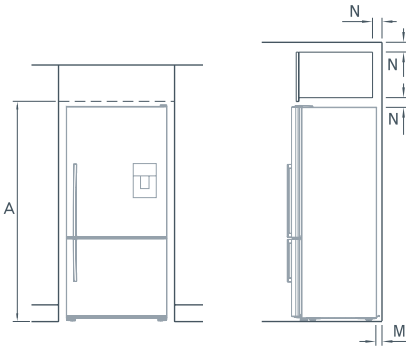

RF610A/RF540A/RF201A

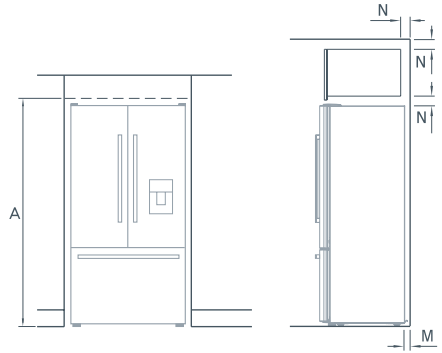

Flush with refrigerator chassis – full door rotation

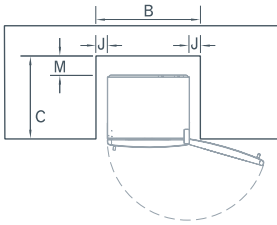

Flush with refrigerator chassis – full door rotation

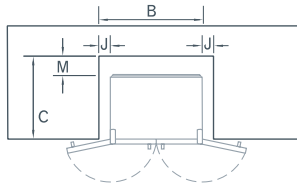

Flush with refrigerator door – 90° door rotation

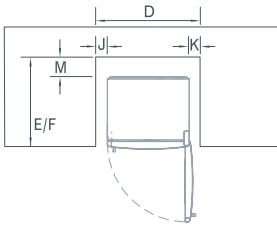

Flush with refrigerator door – 90° door rotation

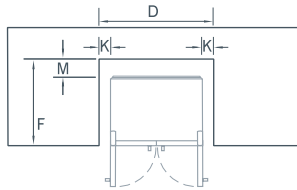

Flush with refrigerator door – full door rotation

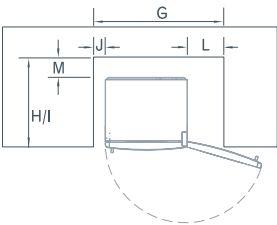

Flush with refrigerator door – full door rotation

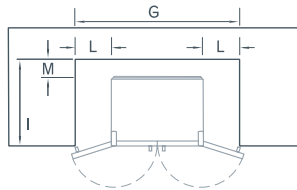

3. Ventilation and installation

- To ensure adequate ventilation for your refrigerator see recommended cabinetry dimensions below.
- The appliance is intended to be placed against a wall with a free distance not exceeding 75 mm.

Cabinetry dimensions (mm) (including minimum air clearances)	E402B	E442B	E522B	RF610A RF540A RF201A
A inside height	1745	1745	1745	1810
Flush with refrigerator chassis – full door rotation				
B inside width	675	720	830	940
C inside depth	620	620	620	620
Flush with refrigerator door – 90° door rotation				
D inside width	680	725	835	950
E inside depth flush to curved door	–	675	675	–
F inside depth flush to flat door	690	690	690	690
Flush with refrigerator door – full door rotation				
G inside width	795	840	950	1180
H inside depth flush to curved door	675	675	675	–
I inside depth flush to flat door	690	690	690	690
Minimum clearances				
J side clearance	20	20	20	20
K side clearance – hinge side flush with door – 90° rotation	25	25	25	25
L side clearance – hinge side flush with door – full rotation	140	140	140	140
M rear clearance (incl. evaporator tray)	30	30	30	30
N vent	50	50	50	50

4. Installation

Your Fisher & Paykel *Active Smart™* refrigerator is fitted with front and rear rollers, designed for moving the product in the forwards and backwards direction.

Avoid moving the product in a sideways direction as this may damage the rollers or the floor covering/surface.

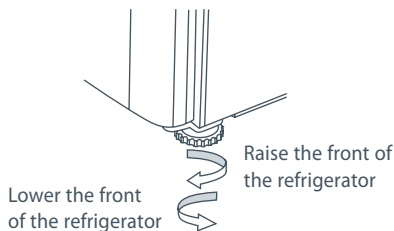

Fig.10 Refrigerator feet

- A Your refrigerator will arrive with the front feet wound up making moving the product into its final location a simple task.
 - B Roll the refrigerator into its final position making sure there is the correct air gap between the product and surrounding cabinetry. See minimum clearance in cabinetry dimensions table (refer to page 11).
- (RF610A, RF540A, RF201A only)**
- C Adjust the front feet down until the refrigerator is leaning backward with the front approximately 10 mm higher than the back. This will ensure a good door closing action. (Refer to Fig.10).
 - D Aligning your refrigerator with cabinetry.
 - Align the sides of the refrigerator with the cabinetry by adjusting the hinge side front foot.
 - Adjust the handle side foot until it touches the floor and takes a small amount of weight.
 - Once the refrigerator is in place and aligned with cupboards/alcove push gently on the front top and check if the product is rocking or stable.

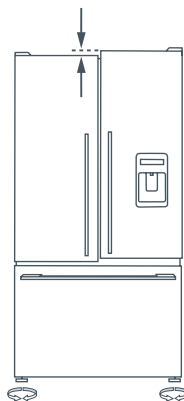

Fig.11 Uneven door alignment

5. Levelling of refrigerator door (RF610A, RF540A, RF201A only)

- For uneven surfaces, front feet can be used to align the 2 doors.
- If left hand door is too low, then unscrew the left hand foot to lift up the cabinet until the two doors top edges are aligned.
- If right hand door is higher, then process the same way with right hand foot.

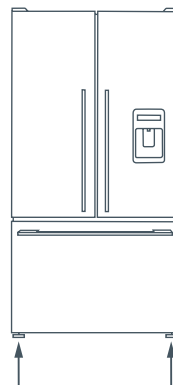

Fig.12 Even door alignment

6. What to do if your product is unstable

- E** Gently push the refrigerator back until the rear rollers contact floor.
- Measure the gap under the front foot, which has come off the floor.
 - Obtain some solid packing material (hardwood, plastic etc) which fits firmly into the gap under the foot.

Note: Do not use metallic materials that may corrode and stain or damage floor coverings.

- F** Wind both front feet up and roll the product out of position.
- Place the packing material in the location diagonally opposite the front roller that lifts off the floor.
 - Make sure the packing material stays in place when the product is pushed back into position.
 - Ideally, the packing material is large enough to rest against the back wall so as to prevent it moving when the cabinet is pushed into position.

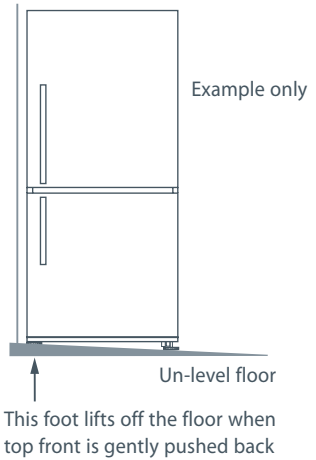

Fig 13. Unstable refrigerator

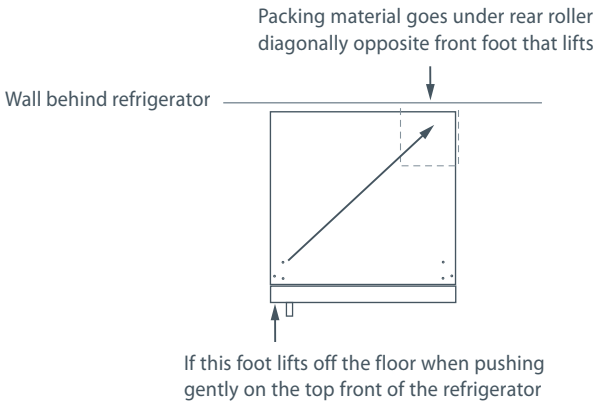

Fig.14 Stabilizing your refrigerator

- G** Roll the refrigerator back into position and adjust front feet as per step D. (Check alignment and door closing action are satisfactory).
- Make small adjustments to front feet where necessary.
 - Check that the product is stable (all 4 feet are on the floor). If not return to step E and repeat steps F and G.

Before placing food in the fresh food or freezer compartments

- Remove all packaging. Ensure that all transit clips are removed from the refrigerator. These are small rubber stops located at the back of the shelves.
- Allow the refrigerator and freezer to run empty for 2 – 3 hours to allow each compartment to cool to the appropriate temperature.
- Clean the inside of the appliance with warm water and a little liquid detergent to remove manufacturing and transportation dust.
- The appliance may have an odour on its initial operation, but this will go when the refrigerator and freezer have cooled sufficiently.

Energy efficiency

- Do not cover your appliances with any material that will prevent air from flowing around the cabinet sides.
- Do not leave the door open for any longer than is necessary.
- Allow good clearances in front of the air ducts within the cabinet for maximum cold air distribution.

Moving or storing your refrigerator

If your refrigerator or freezer is turned off for any reason, wait 10 minutes before turning it back on. This will allow the refrigeration system pressures to equalise before restarting.

Moving your refrigerator

- Turn off the appliance and unplug from the power point. Remove all food.
- Turn the adjustable feet to the right as far as they will turn (refer to page 12).
- Ease the refrigerator out of its position. Tuck the power cord away and tape the doors closed. Tape the shelves in place. If the cabinet needs to be placed at an angle or laid down, carefully lay it on its side (the right hand side when viewed from the front).
- Relocate and install. If the appliance has been left on its side for any length of time, leave it standing upright for at least 10 minutes before turning on.

Storing your refrigerator or freezer

- When storing your cleaned appliance, leave the door(s) open. This allows air to circulate and prevents the build up of bacteria and moulds.
- Before using again, clean well using a mixture of warm water and baking soda (add 1 teaspoon of baking soda to each 500 ml of water). Rinse with clean water.

Holiday time

We recommend you leave your refrigerator or freezer operating while you are on holiday.

- Check refrigerator is switched on and has cooled for at least 2 hours (refer to page 23 – The temperature of your refrigerator and freezer) before use.
- Check that the water filter has been connected and turned on.
- Turn on ice maker (refer to page 19).
- At first use allow approximately 1 minute from when the dispensing pad is pushed until water is dispensed. This will allow the tank to fill.
- Run through and discard the first 3 L (3 qt) of water from the dispenser, stopping intermittently (refer to page 18 – First use). Failure to do this will result in excessive dripping from your dispenser.
- Discard the first bin of ice (refer to page 19 – First use).

You are now ready to enjoy ice and water from your *Active Smart™* refrigerator.

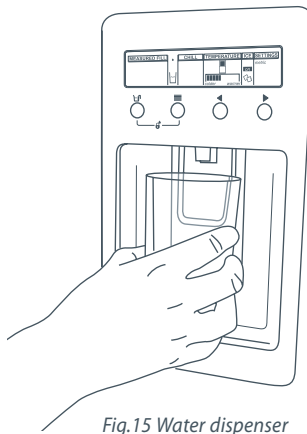

Fig.15 Water dispenser

Please note that once installation is complete a few drips may appear out of the dispenser over the next few days as the remaining trapped air is cleared.

16 All about the display

The display screen enables you to view and modify all the features and options on your fridge. For example, you can change the temperature in your fridge or freezer, and select the Freezer Chill function when you want to quickly freeze meat. You may want a measured amount of chilled water when you are cooking, or want to quickly chill a bottle of wine when friends arrive unexpectedly.

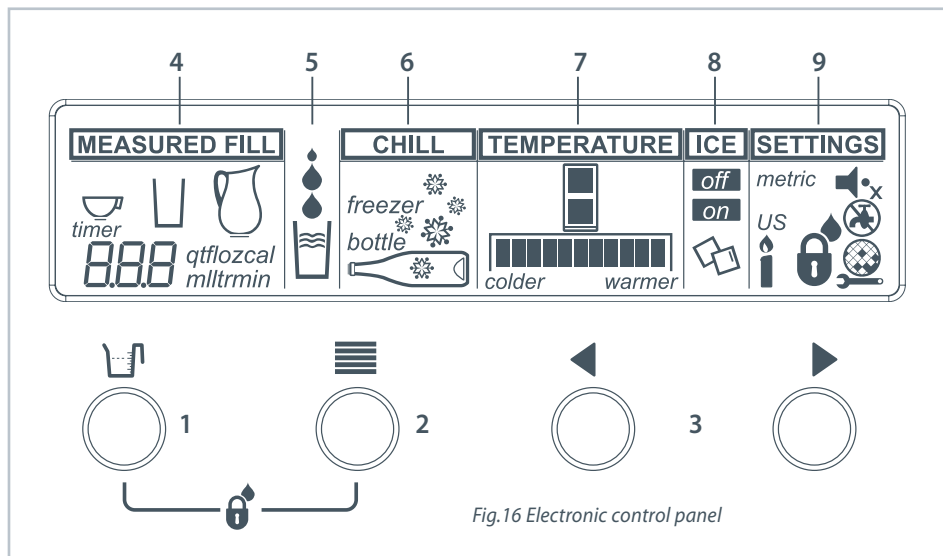













Fig.16 Electronic control panel

Keys

For more detailed information on these functions please refer to pages 18 – 25.

	1. Measured Fill (see page 21)
Enables you to select the amount of water to be dispensed.	
	2. Main menu
Scrolls through the main menu. (Chill, Temperature, Ice and Settings).	
	3. Arrow keys
Scrolls through the settings of each function.	

Display features

MEASURED FILL	<p>4. Measured Fill (see page 21)</p> <p>A pre-measured volume of water can be selected and dispensed automatically.</p>
	<p>5. Dispensing water (see page 18)</p> <p>Animation shows you water is being dispensed.</p>
CHILL	<p>6. Chill (see pages 22 – 23)</p> <p>Freezer Chill When activated this feature boosts cooling in your freezer, optimising the rate at which your foods are frozen.</p> <p>Bottle Chill Your drinks can be chilled more rapidly using this function. An alarm will alert you when they are ready.</p>
 <i>freezer</i>  <i>bottle</i>	
TEMPERATURE	<p>7. Temperature (see page 23)</p> <p>The temperature setting can be individually adjusted for each compartment.</p>
 <i>colder warmer</i>	
ICE	<p>8. Ice (see page 19)</p> <p>The ice making function can be turned on or off.</p>
  	
<i>metric</i>	<p>9. Settings/User alerts (see page 24)</p> <p>Water conversion Your volume can be displayed as either US or metric units.</p>
<i>US</i>	
	<p>Key Silent Mode All key presses can be silenced.</p>
	<p>Key and dispenser lock Dispenser lock – disables the buttons and prevents water from being dispensed.</p>
	<p>Key lock – disables the buttons.</p>
	<p>Sabbath Mode Can be activated if necessary (refer to page 24).</p>

Dispensing pad

Your water dispenser has been designed for one handed operation. Simply push your glass up against the dispenser pad found at the back of the dispenser area. This pad requires only a gentle press to activate.

Please remember that pressing very hard against the dispensing pad will not make the dispenser operate faster or produce greater quantities of water.

First use

- After installation, on the first use, allow approximately a one minute delay from when the dispensing pad is pushed until water is dispensed. This will allow the tank to fill completely.
- The  symbol will flash while the water reservoir fills up. Once the reservoir is full, the symbol will stop flashing.
- After you fill the tank for the first time, dispense and discard approximately 3 L (3 qt) stopping intermittently to flush the tank out.



Dispensing

- Unless Measured Fill is selected, water will be dispensed in free-flow mode. (For more information on Measured Fill refer to page 21).
- To dispense water push the dispensing pad gently, using a glass or container.
- When you dispense water, a light will appear above the dispensing area, and on the display screen. The water fill icon  will also appear.
- To stop the flow of water, simply pull your glass away from the dispensing pad.

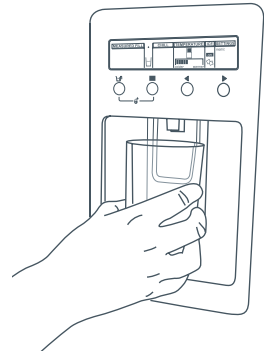

Fig.17 Water dispenser

Important!



To avoid damage to property or personal injury do not put hands, fingers or objects up the dispenser opening.

Please note that once installation is complete a few drips may appear out of the dispenser over the next few days as the remaining trapped air is cleared.

on**Ice maker**

Your ice maker is designed to automatically dispense ice until it senses that the bin is full. So the more ice you use, the more it makes. It is even clever enough to sense when there is no bin in place to catch the ice.

First use



- When you first turn your refrigerator on after installation, the ice maker will be off.
- To turn your ice maker on use the  button to scroll to the **ICE** screen. Use the  or  button to turn the ice maker on or off.

on

Shows the ice maker is on.

off

Shows the ice maker is off.

- Press   together to force a cycle. The ice tray will flip. Force another cycle. The ice tray will flip and spill the water into the ice bin. Empty water and replace bin.
- If the bin is full, or inserted incorrectly the ice maker will not operate. When the bin is inserted correctly the scoop will be on the right hand side of the bin for models E402B, E442B and E522B and the front of the bin for models RF610A, RF540A and RF201A (refer to Fig.19 on page 20). If the bin is removed the ice maker will not operate
- Once your ice maker is in operation, discard the first bin of ice cubes. This will flush away any impurities in the water line and ensure that you get the best quality ice. We recommend that you also do this after vacations or extended periods of not using ice.
- We recommend that you turn the ice maker off if:
 - The water supply is to be off for several hours or
 - The ice storage bin is to be removed for a period of time or
 - You are going on holiday/vacation.

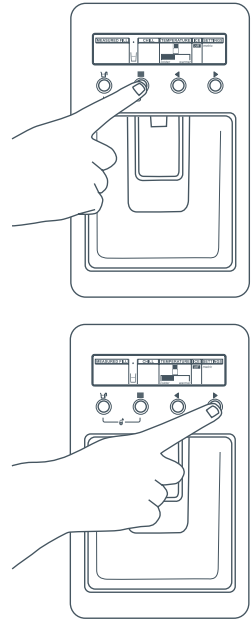
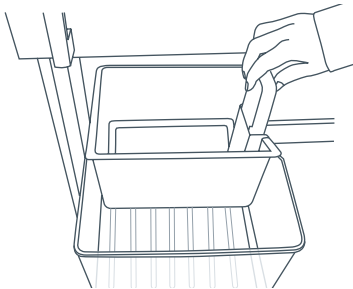

Fig.18 Turning ice maker on

Information about your ice maker

- Your automatic ice maker will produce approximately eight cubes of ice every 2 – 3 hours, depending on freezer compartment temperature and number of door openings.
- The ice cube tray will fill with water after the freezer has reached the correct temperature. First cubes will normally freeze after several hours.
- When cubes are frozen, they will be ejected from the mould into the ice storage bin.
- Ice making will continue until the storage bin is full.
- Ice making will resume when the ice is used.
- For maximum ice storage, level the stored cubes with the ice scoop.
- Your Ice & Water product comes with a smaller ice bin inside the larger freezer bin. Attached to this is a scoop for the ice.
- If a large amount of ice is required, remove the smaller storage bin and allow ice to fall into the larger bin.
- If ice is not used often, old cubes will become cloudy, taste stale, will shrink and may stick together. Empty the ice storage bin periodically and wash in lukewarm water. Dry thoroughly and place back.



E402B, E442B, E522B

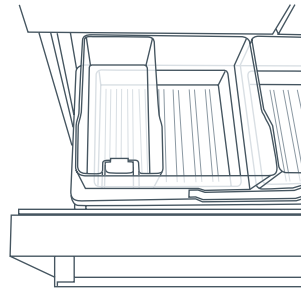

RF610A, RF540A, RF201A

Fig.19 Ice storage bin and scoop in correct position

Important!

- *Avoid contact with the moving parts of the ice maker ejector mechanism, and do not place your fingers on the automatic ice making mechanism while the refrigerator is in operation.*
- *Do not use ice cubes that may have become discoloured, usually with a green-blue colour. If such discolouration is noted, discard the ice cubes and contact your local authorized service centre.*
- *Ensure the ice maker is connected to the filter and to a drinkable water supply only.*
- *Installation of the water connection to the ice maker must be completed by a qualified service technician (see installation instructions).*

Measured Fill

One useful feature of your water dispenser is its ability to dispense a pre-measured amount of water. This comes in handy when cooking or preparing drinks.

- Press the  button to highlight the **MEASURED FILL** screen and again to cycle through the preset quantities.

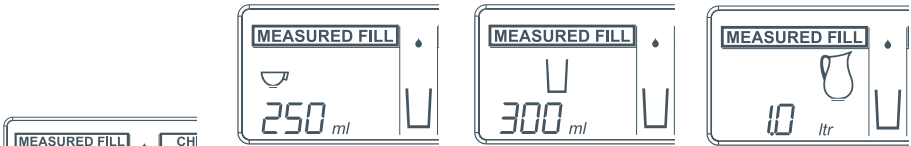

Fig.20 Metric display

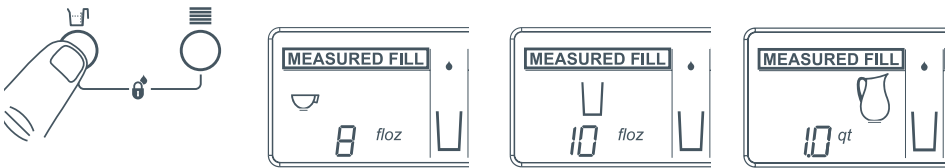







Fig.21 US display

- Push the dispensing pad to receive the pre-selected quantity of chilled water. The units will count up to confirm operation.
- If you stop dispensing part way through your pre-selected quantity the dispenser will remember the remaining quantity to be dispensed for a short time. Simply continue by pressing the pad.
- The  and  buttons can be used to increase or decrease the pre-set measurements in 25 ml, (1 oz) increments, to a maximum of 1 L (1 qt).

Changing the Measured Fill units

The pre-set measurements can be displayed in US imperial or metric units.







The unit setting can be changed by pressing the  button to scroll to the **SETTINGS** screen and pressing the  and  buttons until the desired units are displayed. To return to the Measured Fill option, press the  button.

22 Using the display options

Freezer Chill

We have created the Freezer Chill feature to help you to get the best possible results when freezing fresh food. Freezer Chill boosts freezing speed, which helps to ensure that vital freshness, texture and taste are retained during the freezing process.

The Freezer Chill feature drops the freezer to its coldest temperature for a 12 hour period and then returns to its normal mode. You may wish to use this when freezing a quantity of meat or when you are making frozen desserts.

- To activate, use the  button to scroll to the **CHILL** screen. Then use the  button until  is displayed.
- To deactivate manually, use the  button to scroll to the **CHILL** screen. Then use the  and  buttons until there is no  icon in the **CHILL** screen.

For best results, we recommend that you activate the function approximately 2 hours before it is required. Alternatively, activate it when placing food into the freezer.

Bottle Chill

This function allows you to chill your beverages in the freezer without the worry of forgetting about them.

When activated Bottle Chill will remind you to remove your beverage by sounding an alarm. The user alarm will continue to sound until any key on the panel is pressed.

The time taken to chill depends on the size of your beverage. Bottle Chill allows you to customise this chill time.





Recommended times:

20 minutes – can or small bottle.

25 minutes – wine bottle or similar size beverage.

30 minutes – larger bottle.

If you remove your beverage from the freezer and it is not chilled to your liking, reset the timer to 10 minutes and place the beverage back into the freezer.

- To activate, use the  button to scroll to the **CHILL** screen. Then use the  button until  is displayed.
- Then use the  button to select 10, 15, 20, 25 or 30 minutes as displayed on the left hand side of the screen in the **MEASURED FILL** screen.
- An alarm will sound after the amount of time selected has elapsed.
- Press any button on the display to silence the alarm. Remember to remove the beverage from the freezer.

Bottle Chill contd...



Important!

Do not leave the bottle inside the freezer longer than the time needed for chilling.

- To deactivate Bottle Chill manually, use the  button to scroll to the CHILL screen, then use the ◀ and ▶ buttons until there is no icon in the CHILL screen.

Note: The freezer chill and bottle chill option cannot be used at the same time.

The temperature of your refrigerator and freezer

- When the refrigerator is first turned on it will take approximately 2 to 3 hours to cool, depending on the humidity and temperature of the environment.
- To adjust the temperature of a compartment, use the  button to scroll to the TEMPERATURE screen, use the  button to select the compartment to change.
- The temperature can then be adjusted using the ▶ button to make the compartment warmer or the ◀ button to make the compartment colder.
- The temperature setting will be indicated on the icon below.

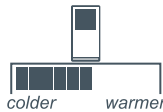



It is important to have your refrigerator set to the correct temperature. Setting it too cold may cause some items in the refrigerator to freeze, and setting it too warm will decrease the storage life of your food.

- For further information on food storage refer to the Food Care section (pages 37 – 39).

Settings

Water unit conversion

- You can change the units your refrigerator uses between US and metric units. To change the units press the  button to scroll to the **SETTINGS** screen option and press one of the  or  buttons until the desired units are displayed.







Key Silent Mode

- The Key Silent Mode allows you to silence all key presses.
- It can be activated or deactivated by holding the  button for four seconds.

When Key Silent Mode is on  will appear.
When this function is off no symbol will appear.

Note: Faults, Bottle Chill timer and the door alarm will still sound when the refrigerator is set on Key Silent Mode.

Key and dispenser lock

- The dispenser lock disables the buttons and prevents water from being dispensed.
- Key lock disables the buttons.
- Activate by holding down both the  button and the  button together.
- After 2 seconds  icon will appear indicating dispenser lock is activated.
- After 2 more seconds  icon will appear indicating key lock is activated.
- To de-activate, hold down both the  button and the  button together for 2 seconds.

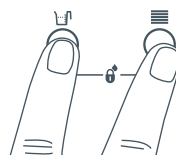





Fig.22 Key and dispenser lock

Sabbath Mode

- In Sabbath Mode alarms, lights and displays are deactivated.
- Sabbath Mode can be activated or deactivated by holding down the ,  and  button for 4 seconds.

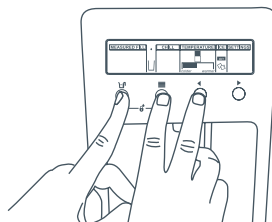

Fig.23 Sabbath Mode

Settings

Once in Sabbath Mode:

- The interior light will not turn on when the refrigerator is opened.
- The door alarm will not operate.
- The display will not be illuminated.
- Electronic control panel will not work.

Note: If power is turned off the refrigerator will automatically continue in Sabbath Mode once power is restored. Sabbath Mode will automatically de-activate after 80 hours.

User warnings

Your refrigerator is clever enough to diagnose it's own problems. It will alert you when there is a fault.



No water

The no water icon  will appear when the water supply to the refrigerator is interrupted. Please refer to the Troubleshooting checklist (refer to pages 40 – 43).



Filter reset

The filter reset icon  will appear when the water filter needs changing. This will flash when dispensing water. To change the filter and reset the filter icon refer to pages 28 – 29.



Fault

- In the unlikely event a fault occurs the  icon appears on the front of the display and a fault code will be displayed on the left in the **MEASURED FILL** screen.
- When the door is open the refrigerator fault alarm will sound. To silence this press any button on the display.
- Please take note of the fault code and contact our Customer Care Centre. Details of Customer Care phone numbers can be found in the back of this book.

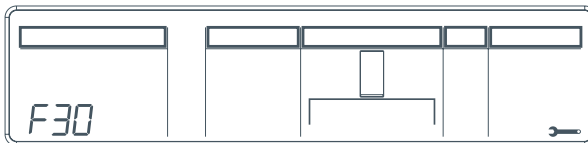

Fig.24 Fault code display

Fruit and vegetable bins and humidity control cover

The fruit and vegetable bins feature a unique cover which provides two functions:

- The humidity cover seals the bins and provides a humid microclimate to extend storage times of fruits and vegetables.
- The humidity cover prevents condensation, which forms at high humidities, from dripping down onto the fruit and vegetables. The ability to retain high humidity in the fruit and vegetable bin may produce small amounts of water in the bottom of the fruit and vegetable bins. This can be wiped out as required.

Fruit and vegetable bins and humidity slide (where fitted)

- Each fruit and vegetable bin has a humidity adaptor control that can be adjusted to fruit or vegetables depending on what is stored in the bins.
- If possible try to store fruit and vegetables separately. This will help extend their storage life.
- If there is a mixture of fruit and vegetables in the bin adjust the position of the control to the centre.
- If there is too much water in the bins the control can be adjusted towards the setting with fewer drips.
- Remember a small amount of water in the bins is beneficial for fruit and vegetable storage.

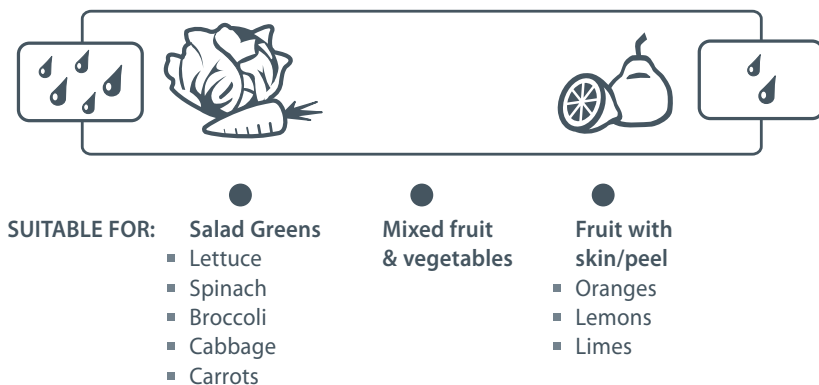

Fig.25 Humidity Control graphic

Slim storage drawer (where fitted)

The bins at the bottom of the refrigerator provide storage space for items that you may want to keep separate from the rest of the refrigerator. These slim storage bins can be used for deli item storage, beverages or defrosting foods.

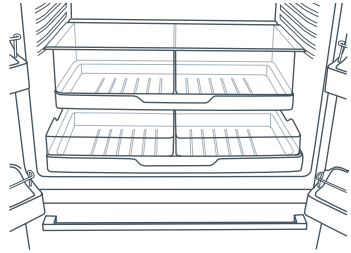

Fig.26 Slim storage drawer

Door alarms

- If the fresh food compartment door is left open the alarm will beep after 90 seconds and if the freezer door is left open the alarm will beep after 60 seconds.
- While either door remains open, subsequent beeps will sound every 30 seconds for 5 minutes.
- A continuous alarm will sound if the door has been left open for 5 minutes or longer and the light will turn off. The alarm will stop when the door is closed.

Bottle rack (where fitted)

- The bottle rack can be used to store a variety of bottles and can be positioned anywhere you would a shelf. To re-position, lift the rear of the rack and pull forward. Bottles are best stored with the neck of the beverage facing the front of the refrigerator.

All the water to your fridge is filtered to remove impurities through a cartridge located in a position of your choice outside the refrigerator. Of course, this will need changing approximately every 6 months or up to 2800 L (740 gallons) depending on the quality of the incoming water and how much you use the dispenser.

- There is a replacement indicator  icon on the control panel which will appear when the filter needs replacing. It will flash, when dispensing water, as a reminder.
- Replacement cartridges are available from your authorised Fisher & Paykel Dealer. The details of the replacement cartridge are on the label on the cartridge.

Changing the water filter cartridge

It is not necessary to turn off the water supply before attempting to change the water filter cartridge.

- 1 Grasp and firmly twist the cartridge in an anticlockwise direction (to the left when installed in the recommended orientation) as shown in Diagram 1.
- 2 Pull the cartridge away from the filter head (down when installed in the recommended orientation) as shown in Diagram 2.
 - It is not unusual for a few drops of water to be present when filter is removed.
- 3 Discard old filter.
- 4 Filter installation:
 - Remove protective cap on spigot on head.
 - Push the cartridge up towards filter head while rotating it in a clockwise direction (to the right when installed in the recommended orientation) as shown in Diagram 3.
- 5 Reset filter indicator icon on the display (this will set to remind you when the filter is due to be replaced again). Refer to page 29.
- 6 Dispense 5 L (5 qt) to flush the cartridge, removing trapped air and harmless carbon fines.
- 7 A few drips may appear out of the dispenser over the next few days as the remaining trapped air is cleared.

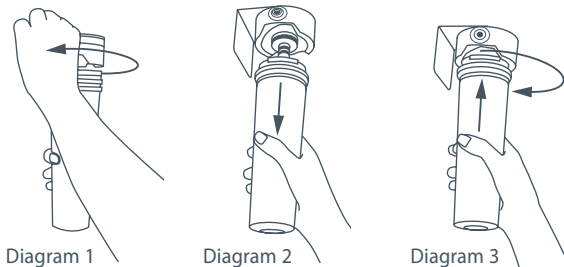





Fig.27 Changing the water filter cartridge

To reset the filter indicator

Important!





We recommend the water filter is used from installation.

Do not reset monitor before filter is changed or filter monitoring will be inaccurate.

- Press and hold  and  buttons for 4 seconds to reset the filter indicator.
- If present the  icon in the **SETTINGS** screen will disappear when reset.

To disable the filter indicator

Note: if disabled, you will not be reminded to change your filter.

- When no filter is to be fitted, you can disable the filter indicator.
- Press and hold ,  and  buttons for 4 seconds to turn this feature off/on.
- When activated or deactivated the  icon will flash and on or off will be displayed in the **MEASURED FILL** screen.
- We recommend that you do not disable the filter indicator if you have a filter fitted to the connection.

Important!

- *To avoid serious illness or death, do not use the water filter where water is unsafe or of unknown quality without adequate disinfection before or after use of filter.*
- *The water filter cartridge needs to be changed when the filter indicator icon flashes on the interface panel.*
- *We recommend the water filter cartridge is replaced when the  icon flashes. This will happen every 6 months or 2800 L (740 gallons).*
- *If the water filtration system has been allowed to freeze, replace filter cartridge.*
- *If the water filtration system has not been used for several months and water has an unpleasant taste or odour, flush system by dispensing 3 L (3 qt) of water. If unpleasant taste or odour persists, change filter cartridge.*

Measured Fill Calibration

The accuracy of your Measured Fill function can be affected by variations in the incoming water pressure. The Measured Fill Calibration Mode allows you to fine-tune the amount of water dispensed from the preselected volumes on your cabinet.

The calibration mode is worked out as a percentage. You can measure the amount the refrigerator is under filling or over filling and increase or decrease the calibration to get the exact amount you want.

To assess whether the Measured Fill function is under or over filling:

- Press the **MEASURED FILL** button until 1 L (1 qt) is displayed.
- Dispense this amount into a measuring jug.
- Estimate the amount of water that has been dispensed into the jug.
eg 975 ml = under filling by 25 mls or 31 floz = under filling by 1 floz

To calculate the Calibration factor:

- Transfer the difference into a percentage.
eg $1000/975 = 1.03 = 103\%$ or $32/31 = 1.03 = 103\%$
- Enter the Calibration mode by pressing and holding the **MEASURED FILL** and **←** buttons together for 4 seconds.
- 100CAL will be displayed.
- The number displayed is a percentage. Adjust this accordingly using the **←** and **→** buttons.
eg 100CAL = 103CAL
- Press the **MEASURED FILL** button to confirm your selection.

Please note:

- The Measured Fill function has an accuracy of +/-5% at the time of calibration.
- The accuracy of your calibration will of course be subject to the accuracy of your measuring device and method.

Calibration quick reference guides

Metric

Actual amount of water received	Under filled	Difference from 1 L	Adjust display to read (calibration factor)
Underfilling – you dispense 1 L but the amount of water you receive is actually less than 1 L			
975 ml	25 ml	3%	103 CAL
950 ml	50 ml	5%	105 CAL
Overfilling – you dispense 1 L but the amount of water you receive is actually more than 1 L			
1025 ml	25 ml	2%	98 CAL
1050 ml	50 ml	5%	95 CAL

US

Actual amount of water received	Under filled	Difference from 32 floz	Adjust display to read (calibration factor)
Underfilling – you dispense 1 qt but the amount of water you receive is actually less than 1 qt			
31 floz	1 floz	3%	103 CAL
30 floz	2 floz	7%	107 CAL
Overfilling – you dispense 1 qt but the amount of water you receive is actually more than 1 qt			
33 floz	1 floz	3%	97 CAL
34 floz	2 floz	6%	94 CAL

Replacement of the interior light (Halogen light bulb)

Turn the power off at the wall socket before replacing the bulb. The light bulb is located on the top roof of the cabinet at the front.

- Remove the lens cover using a small screwdriver. Insert the screwdriver in the front centre of the lens cover and gently lever down. Pull out old bulb.
- Do not touch the new bulb with your hand. Leave it in the plastic bag whilst slotting into position.
- Remove plastic bag when bulb is in position.
- Replace lens cover.
- Turn power on. Light bulb should now glow.

Note: The replacement halogen bulb must not exceed 12 Volt/10 Watt. Bulbs are available from your Fisher & Paykel Appliances Customer Care Centre.

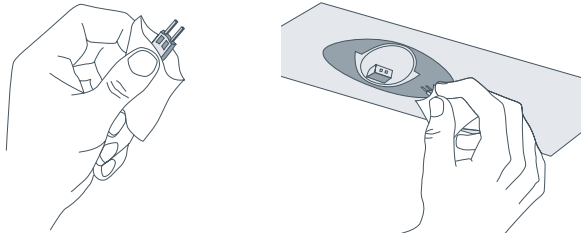

Fig.28 Halogen light replacement

Important!

Your refrigerator is designed to operate for many years without the need for service checks. However, if your refrigerator is malfunctioning, have it attended to by your Fisher & Paykel Appliances Authorised Service Centre as soon as possible. All electrical repairs must be carried out by an adequately trained service technician or qualified electrician.

Exterior

Stainless exterior doors (Iridium or EZKleen finishes)

- It is important when cleaning the exterior door surface of your refrigerator, to only use liquid dishwashing detergent dissolved in warm water.
- Dry the door with a clean, lint free cloth.
- The use of any abrasive or stainless steel cleaners and solvents will damage the door surface.

Water dispenser pad and interface

- We have incorporated a Dispenser and Key Lock function in your refrigerator to make cleaning easier (refer to page 24). This will help you to avoid accidental water dispensing while you clean.
- Clean the pad and interface panel with a soft damp cloth.

Other exterior surfaces

- Clean all other exterior surfaces with warm water and detergent.
- If necessary, clean the magnetic door gasket and the centre door gaskets with an old toothbrush, warm water and liquid dishwashing detergent.

Water evaporator tray

- The water evaporator tray is found above the compressor at the back of the refrigerator or freezer. The tray may require infrequent cleaning.
- Carefully move the refrigerator or freezer out from the wall.
- Switch off the appliance.
- We do not recommend that you remove the evaporator tray. If cleaning is required, excess water can be soaked up from the evaporator tray using a sponge. Wipe out with warm water and detergent or disinfectant.
- Reassemble taking care not to over-tighten the fasteners.
- Switch on the appliance.



Interior

- It is important to keep the interior of the refrigerator and freezer clean to help prevent food from becoming contaminated during storage.
- The amount and types of food stored determines how often cleaning should be carried out (ideally once every 1 to 2 weeks) in the refrigerator.
- Remove the shelves from cabinet and door. Wash shelves and storage bins in warm water and detergent; rinse in clean water and dry before replacing.
- Wipe over the interior surfaces with warm water and detergent or baking soda dissolved in warm water (add 1 teaspoon of baking soda to each 500 ml (½ qt) of water). Rinse with clean water.
- To help remove “old stale refrigerator” smells add a few drops of vanilla essence or vinegar to the water before cleaning.
- Clean exterior surfaces with warm water and detergent. Use a toothbrush for the magnetic door gasket.
- Do not use harsh, abrasive cloths or cleaners or highly perfumed, strong smelling cleaners or solvents on any part of the refrigerator or freezer.

Glass shelves

Clean with warm water and detergent or a glass cleaner. If cleaning the shelves without removing from the cabinet, use only warm water and detergent as a glass cleaner can damage the plastic components of your refrigerator.

Bottle rack

- Clean with warm water and detergent. The use of abrasive cleaners and solvents may cause damage.

Automatic ice dispenser

- We do not recommend you clean the ice maker componentry, but it is important to clean the bins occasionally.
- The storage bin should be cleaned regularly and the old ice in the bottom of the bin discarded.
- Wash bin in lukewarm water. Dry thoroughly and replace.
- When replacing the bin ensure that the scoop is on the right hand side.

Important!

Many commercially available cleaning products contain solvents that may attack the plastic components of your freezer and cause them to crack. It is important to use only warm water and a small amount of liquid dishwashing detergent on any plastic components inside and outside your freezer. Avoid using anti-bacterial cleaning products on either the interior or exterior of the cabinet as they may cause rusting of metal components and cracking of plastic components.

Humidity Control System

Important!

When cleaning the shelf above the vegetable bins, we recommend that you do not disassemble the Humidity Control System from the shelf.

In the event that the plastic lid and humidity slides become separated from the glass shelf, follow these instructions to reassemble.

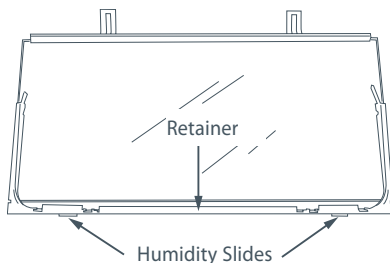

- 1 Turn shelf upside down
- 2 To attach humidity slides onto shelf front corners, fit bottom clips into shelf front trim. Next, slide sideways towards shelf until arm clips onto glass.

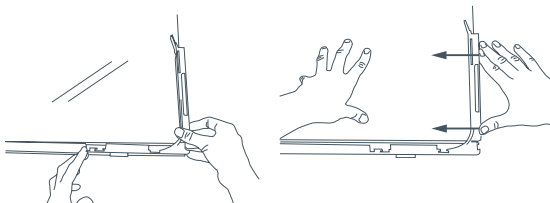

- 3 To attach humidity control lid – with text facing you, align lid with front of shelf. Hold lid vertically and fit front end into retainer on shelf. Ensure lid fits into retainer as well as underneath humidity slides.

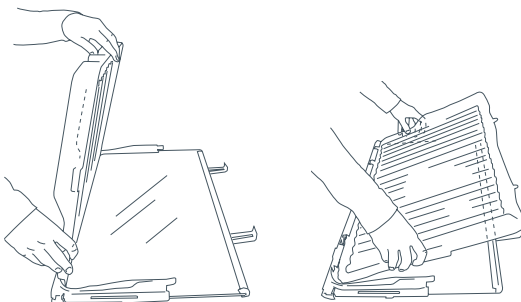

- 4 At the sides of the shelf, adjust humidity slide tabs so that the plastic lid is between the shelf and the tabs.
- 5 If clips on back of shelf are present, fasten lid with rear clips. Ensure that the cover is fully secure at front and back of shelf.

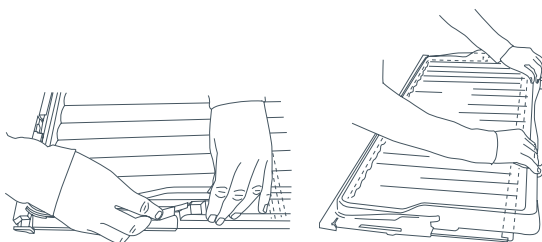

Fig.29 Humidity Control System cleaning

To remove trays or fixed bins

- For ease of removal, empty food from tray/bin first.
- Hold the centre front of the tray/bin handle.
- Lift vertically to unclip from the runners and pull tray/bin towards you to remove.
- Push both runners back into refrigerator.

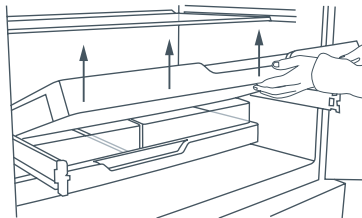

Fig.30 Tray removal

To replace trays or fixed bins:

- With the runners pushed back into the refrigerator, place the tray/bin on top of the runners. Push the tray/bin back slowly until you feel it clip back onto the runners.

Important!

- *Ensure that trays and bins are securely clipped onto the runners before use.*
- *Bin and tray runners are pre-lubricated, and will not need to be re-lubricated during their life. Do not attempt to clean grease from the runners, as this will affect their ability to function. Do not immerse runners in water.*

Permanently fixed bins and trays (model RF610A/RF540A/RF201A only)

The freezer bins and trays in this model are permanently fixed. They cannot be removed from the freezer compartment. To clean simply wipe with a soft, damp cloth.

On vacation/holiday

- Switch the ice maker to off on the interface panel (refer to page 19).
- Shut off the water supply to the refrigerator.
- On return turn on the water supply to the refrigerator.
- Dispense 3 L (3 qt) of water and discard to ensure the tank is refilled with fresh water.
- Turn on the ice maker (refer to page 19).
- Throw away the first bin of ice cubes.

Normal refrigerator sounds

Active Smart™ refrigerators, with their excellent energy ratings and cooling performance, can produce sounds somewhat different to your old refrigerator.

Normal operational sounds include:

- Fan air flow sound. *Active Smart™* refrigerators have fans which change speed depending on demand. During cooling periods, such as after frequent door openings, fans circulate the cold air in the refrigerator and freezer compartments producing some air flow sound. This is quite normal.
- Cracking or popping which may sound like ice coming off the evaporator. This occurs when the defrost function is operating.
- Running water sound. This is the liquid refrigerant in the system and can be heard as a boiling or gurgling noise.
- An audible hissing sound after closing the freezer door. This is due to the pressure difference between the warm air that has entered the cabinet and suddenly cooled, and the outside air pressure.
- Other strange sounds may be heard for the following reasons:
 - Cabinet not level
 - Floor uneven or weak
 - Bottles or jars rattling on shelves
- If this is your first refrigerator with an ice maker, you will hear occasional sounds that may be unfamiliar. They are normal ice making sounds and are not cause for concern.
- The following sounds are normal with the operation of an ice maker:
 - Motor operation (low humming).
 - Running water as the ice maker and/or water tank fills.
 - Water valve opening and closing (hissing sound).
 - Ice being loosened from the ice moulding tray (cracking).
 - Ice dropping into bin (clunking).

Red meat

- Place fresh red meat on a plate and loosely cover with waxed paper or plastic wrap or foil.
- Store cooked and raw meat on separate plates. This will prevent any juices lost from the raw meat from contaminating the cooked product.
- Delicatessen meats should be used within the recommended storage time.



Poultry

- Fresh whole birds should be rinsed inside and out with cold running water. Dry and place on a plate. Cover loosely with plastic wrap or foil.
- Poultry pieces should also be stored this way. Whole poultry should never be stuffed until just before cooking, otherwise food poisoning may result.
- Cool and refrigerate cooked poultry quickly. Remove stuffing from poultry and store separately.



Fish and seafood

- Whole fish and fillets should be used on the day of purchase. Until required, refrigerate on a plate loosely covered with plastic wrap, waxed paper or foil.
- If storing overnight or longer, take particular care to select very fresh fish. Whole fish should be rinsed in cold water to remove loose scales and dirt and then patted dry with paper towels. Place whole fish or fillets in a sealed plastic bag.
- Keep shellfish chilled at all times. Use within 1 – 2 days.

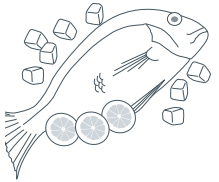

Precooked foods and leftovers

- These should be stored in suitable covered containers so that the food will not dry out.
- Keep for only 1 – 2 days.
- Reheat leftovers only once and until steaming hot.

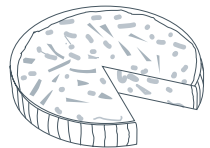

Fruit and vegetable bins

- Although most fruit and vegetables store best at low temperatures, take care not to store the following at temperatures of less than 7°C for long periods: citrus fruit, tropical fruit, tomatoes, cucumbers.
- Undesirable changes will occur at low temperatures such as softening of the flesh, browning and/or accelerated decaying.
- Do not refrigerate avocados (until they are ripe), bananas, mangoes or pepinos. If possible store fruit and vegetables separately, i.e. fruit in one bin and vegetables in the other.
- Each fruit and vegetable bin has a humidity control slide that can be adjusted depending on what is stored in the bins. For more information on using the Humidity Control refer to page 26.

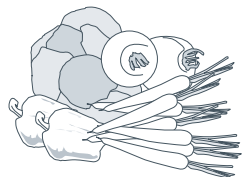

38 Storing food in your freezer

The use of temperatures of -18°C or colder to store food means that the food can be kept for longer periods than when refrigeration temperatures are used. This is because the growth of bacteria, moulds and yeasts are stopped, and chemical and physical reactions are severely restricted at very low temperatures.

Frozen food care

For best results:

- Choose only high quality foods that freeze well.
- Store at -18°C or colder. Take care to maintain this low storage temperature eg try to avoid opening the freezer door unnecessarily. If your ice cream is soft you are running your freezer too warm.
- Leave space at the top of containers, glass jars or plastic bags containing liquids or semi-solid foods. These expand as they freeze. Usually 20 – 50 mm head space is recommended. Seal. Ideally, remove all the air from the package after food is frozen.
- Packages or containers of solid foods should have the air removed from them and be sealed tightly before freezing.
- Use the Freezer Chill function when freezing fresh food. This helps to speed up the freezing process, giving optimum freezing results. It is recommended that the function is activated approx 2 hours before required. For more information refer to page 22.
- Freeze immediately and as quickly as possible. Freeze only small quantities of food at any one time. For best results we recommend that only 1 kg of food be frozen per 25 L freezer capacity. (About 3 kg in small freezers and 4 kg in larger freezers). For faster freezing in *Active Smart™* models, we recommend that fresh food is placed at the top of the freezer compartment close to the air vent.
- Do not pile frozen food around the fan cover. It can prevent adequate air circulation.
- Thaw foods preferably in a refrigerator, or using a microwave oven or multifunction oven.
- Keep a constant turnover of food. Use older items of food first. Do not exceed recommended storage times.
- Use good quality freezer proof packaging to maintain food quality.
- If food is only covered in plastic film place inside a freezer-proof plastic bag.



Recommended freezer storage times

These times should not be exceeded.

	M o n t h s	1	Bacon, casseroles, milk
		2	Bread, ice-cream, sausages, pies – (meat and fruit), prepared shellfish, oily fish
		3	Non oily fish, shellfish, pizza, scones and muffins
		4	Ham, cakes, biscuits, beef and lamb chops, poultry pieces
		6	Butter, vegetables (blanched), eggs whole and yolks, cooked crayfish, minced meat (raw), pork (raw)
		12	Fruit (dry or in syrup), egg whites, beef (raw), whole chicken, lamb (raw), fruit cakes

Meat, poultry and game

- Do not try to freeze more than 1 kg meat per 25 L freezer capacity. Meat must be frozen quickly in order to maintain its texture.
- Do not stuff poultry before freezing.
- Red meat can be cooked from frozen, or from the partly or completely thawed states. Remember to allow extra cooking time if cooking from frozen.
- Always thaw poultry completely before cooking.



Fish

- Fish is best frozen commercially. If however you do want to freeze fish at home, make sure the fish is very fresh and of high quality.
- Clean, scale and preferably leave whole. All fish should be wrapped in two layers of packaging as depending on the type of fish, odours and flavours can be readily transferred either to or from it. Seal well.
- For best results, cook from either the frozen or partly thawed state.

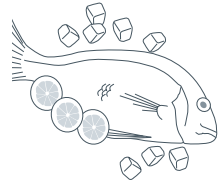

Vegetables

- Most vegetables freeze well, although 'salad' vegetables lose their crispness. Other vegetables eg celery, onion and tomatoes should only be used in cooked dishes as they soften on freezing.
- Freeze only high quality, mature, ready-to-eat vegetables.
- Sort and discard any that are damaged.
- **It is necessary to blanch most raw vegetables prior to freezing.**
- Blanching involves a short cooking period during which vegetable enzymes are destroyed. If these enzymes are not destroyed they cause undesirable physical and chemical changes during freezer storage.
- Vegetables can be blanched in boiling water, steam or microwave oven. If using boiling water, boil vegetables for 2 – 4 minutes and cool quickly.
- In general frozen vegetables are best cooked from their frozen state.

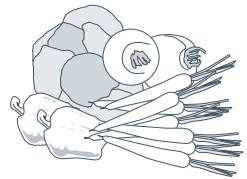

Prepared and cooked foods

- Most cooked foods can be frozen but it is not recommended to freeze the following:
- Cooked egg white, custards, cream fillings and milk puddings, gelatine or jelly-like dishes, mayonnaise and similar salad dressings, meringue toppings. These tend to separate on thawing.

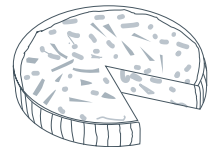

Fruit

- Choose high quality, mature, and ready to eat fruit. Preferably select varieties recommended for freezing.
- Avoid unripe and over-ripe fruit.
- The way fruit is packed depends on how it is to be used. Fruits packed in syrup are ideal for desserts, whereas fruits packed without sugar are better used for cooking. Most fruits can be stored for 8 – 12 months.







If there is a problem with your appliance, please check the following points before contacting your local Fisher & Paykel Appliances Authorised Service Centre Dealer or Customer Care Centre.

Problem	Possible causes	What to do
Appliance does not operate.	No electricity at power outlet.	Check that the plug is correctly connected and power switched on. Check another appliance at the same outlet. Check house fuse.
Light not working.	Blown light bulb(s).	Change light bulb(s) (refer to page 31).
	Refrigerator not working.	Check refrigerator is turned on at wall. If problem continues refer to page 45.
Light and display not working.	Product in Sabbath Mode.	Refer to Sabbath Mode page 24.
Motor operates for long periods.	Hot weather. Frequent door lid openings. Large amount of food recently added.	Minimise door opening to allow temperature to stabilise.
	Temperature control set too low.	See Temperature control section (page 23).
	Doors not sealing properly.	Check that cabinet is level and gasket seals are clean.
Storage compartments too warm.	Temperature setting not correct.	See Temperature control section (page 23).
	Frequent door openings. Large amount of food recently added.	Minimise door openings to allow temperature to stabilise.
Food freezing in the refrigerator.	Temperature setting not correct.	See Temperature control section (page 23).
	Food placed directly in front of air outlets.	Move chill sensitive foods away from the centre back of the shelf.
Unfamiliar noises.	Cabinet not stable or level. Freezer is defrosting.	See Installation section (pages 12 – 13) or refer to Sounds (page 36).
Water in the vegetable bins.	Condensation is formed by the water produced by fruit and vegetables.	A small amount of condensation is beneficial for fruit and vegetable storage. If there is too much water, store fruit and vegetables loosely wrapped in plastic bags. Wipe out water with a cloth. Set humidity slide to low humidity setting 

Problem	Possible causes	What to do
Sides of cabinet are warm.	This is normal.	
Warm area on central door seal.	This is normal.	
Condensation on outside of refrigerator/freezer.	Not unusual during periods of high humidity.	Wipe dry.
Condensation inside fresh food compartment.	Frequent or long door openings.	Minimise door openings.
	Door gasket leaking.	Check that gasket is sitting flat and sealing tightly.
	Not unusual during periods of high humidity.	Wipe dry.
Ice buildup inside freezer compartment.	Freezer door not closing tightly.	Move items in freezer so door can close tightly. Check and clean door gasket seal.
Taste or odour in ice cubes.	Transfer of odour/taste from strong smelling foods.	Wrap or cover strong smelling foods.
Door handles out of alignment.	With time and usage, movement may occur.	See Installation instructions – Stability instructions (pages 12 – 13).
Tray/bin does not slide in and out evenly.	Packaging trapped.	Check to ensure no food or packaging is trapped behind the tray/bin.
	Runners not extending fully.	Holding onto sides of tray/bin, extend the runners fully by using a firm pull – this will reset the runner.

Problem	Possible causes	What to do
Ice maker makes unfamiliar sounds or seems too loud.	Normal ice maker operation.	Refer to refrigerator sounds (refer to page 36).
Automatic ice maker does not work.	Ice maker has not been switched on.	Switch on ice maker (refer to page 17).
	Bin is in the wrong way or no bin at all.	Place bin so scoop is on the right side. Ice bin sits directly under ice maker on top left side of freezer.
	Water supply turned off or not connected.	Connect water supply.
	Freezer compartment not working.	Contact Customer Care.
	Water pressure too low.	Check water pressure.
	Water line kinked/squashed.	Check water line for kinks/squashing.
	Filter clogged.	Water filter may need replacing.
Ice cubes have odour/taste.	Unsealed packages may be transmitting odour/taste.	Old cubes need to be discarded. Ensure food packaging is sealed.
	Interior of freezer needs cleaning.	Ice storage bin needs to be emptied and washed. Clean refrigerator (refer to pages 33 – 35).
	Poor taste from incoming water.	Filter may need changing. A filter may need to be installed.
Slow ice cube freezing.	Door may have been left ajar.	Close door.
	Freezer compartment too warm.	Turn temperature to a colder setting (refer to page 23).
Warm spot on central door seal.	You may feel a warm spot at times on the central seal between the two refrigerator doors.	This is perfectly normal and is part of the normal refrigerator operation.
Wet ice/ice clumping.	Low water pressure.	Check water pressure.
	Filter blocked.	Replace filter (refer to pages 28 – 29).
	Long freezer door openings High ambient temperature Ice bin left out of freezer compartment a length of time Ice will stick together over time.	Gently tap ice with scoop to unstick or, if large clumps occur, empty ice bin and make new ice.

Problem	Possible causes	What to do
Water has poor taste/odour.	Refrigerator not used for an extended period.	Dispense 3 L (3 qt) water so fresh water supply is replenished.
Water dispenser does not work and/or  icon flashing.	Water supply turned off or not connected.	Turn water on. Press dispenser for 2 mins to remove trapped air from water line and to fill the water system.
	Supply line may be blocked. On first installation there may be air in water system.	Check supply for kinks or leaks. To remove air, run a litre or a quart of water through the dispenser.
	Filter may be blocked and need replacing.	Replace filter (see back of this booklet for Customer Care contact details).
	Dispenser lock activated.	Hold down the  and  button for 2 seconds.
	Water frozen in tank.	Increase temperature to a warmer setting in fresh food compartment and freezer.
Water in first glass is warm.	Water dispenser not used for extended period.	Allow 24 hrs for water to cool to set temperature.
	Tank capacity used recently.	Allow water time to cool.
Filter warning light  is flashing.	Filter needs replacing.	Replace filter as soon as possible (refer to pages 28 – 29).
Measured Fill amount of water is inaccurate.	Measured Fill needs recalibration.	Recalibrate (refer to page 30).
Drips overflow drip-shelf.	Air trapped in tank.	Flush 3 L (3 qt) water through dispenser, stopping intermittently.
	New filter installed.	Flush 3 L (3 qt) water through filter and then 3 L (3 qt) through dispenser.

Manufacturers warranty

You automatically receive a 2 year Manufacturer's Warranty with the purchase of this Product covering parts and labour for servicing within the country of purchase.

Fisher & Paykel undertakes to:

Repair or, at its option, replace without cost to the owner either for material or labour any part of the Product, the serial number of which appears on the Product, which is found to be defective within TWO YEARS of the date of purchase.

This warranty DOES NOT cover

- A** Service calls to which are not related to any defect in the Product. The cost of a service call will be charged if the problem is not found to be a Product fault. For example:
 - 1. Correcting the installation of the product.
 - 2. Instructing you how to use the product.
 - 3. Replacing house fuses or correct house wiring or plumbing.
 - 4. Correcting fault(s) caused by the user.
 - 5. Noise or vibration that is considered normal, eg drain/fan sounds, regeneration noises or user warning beeps.
 - 6. Correcting damage caused by pests, eg rats, cockroaches etc.
- B** Defects caused by factors other than:
 - 1. Normal domestic use or
 - 2. Use in accordance with the Product's User Guide.
- C** Defects to the Product caused by accident, neglect, misuse or Act of God.
- D** The cost of repairs carried out by non-authorized repairers or the cost of correcting such unauthorised repairs.
- E** Normal recommended maintenance as set out in the Product's User Guide.
- F** Repairs when the appliance has been dismantled, repaired or serviced by other than an AUTHORISED CUSTOMER SERVICE CENTRE or the selling dealer.
- G** Pick-up and delivery.
- H** Transportation or travelling costs involved in the repair when the product is installed outside the AUTHORISED CUSTOMER SERVICE CENTRE'S normal service area.

Service under this manufacturer's warranty must be provided by an Authorised Service Agent (refer to the Service Contacts section at the start of this book). Such service shall be provided during normal business hours. This warranty certificate should be shown when making any claim.

Note

This Warranty is an extra benefit and does not affect your legal rights.

Please keep this User Guide in a safe place.

Before you call for service or assistance ...

Check the things you can do yourself. Refer to the installation instructions and your user guide and check that:

- 1 Your product is correctly installed.
- 2 You are familiar with its normal operation.

If after checking these points you still need assistance please refer to the following...

In New Zealand if you need assistance...*

Call your Fisher & Paykel retailer who is trained to provide information on your appliance, or if we can be of any further help, please contact our Customer Care Centre,

Toll Free: 0800 FP CARE or 0800 37 2273

Fax: (09) 273 0656

Email: customer.care@fp.co.nz

Postal Address: Fisher & Paykel Appliances Limited, PO Box 58732 Greenmount, Auckland

If you need service...*

Fisher & Paykel has a network of independent Fisher & Paykel AUTHORISED SERVICE CENTRES whose fully trained technicians can carry out any service necessary on your appliance. Your dealer or our Customer Care Centre can recommend an AUTHORISED SERVICE CENTRE in your area.

In Australia if you need assistance...*

Please call our Fisher & Paykel Customer Care Centre.

Toll Free: 1300 650 590

Fax: (07) 3826 9298

Email: customer.care@fp.com.au

Postal Address: Fisher & Paykel Appliances Limited, PO Box 798, Cleveland, QLD4163

If you need service...*

Fisher & Paykel Australia Pty Ltd has a network of independent Fisher & Paykel AUTHORISED CUSTOMER SERVICE CENTRES whose fully trained technicians can carry out any service necessary on your appliance. Our Customer Care Centre can recommend an AUTHORISED SERVICE CENTRE in your area.

In United Kingdom if you need assistance...*

Phone: (0845) 066 2200

Fax: (0845) 331 2360

Email: customer.care@fisherpaykel.co.uk

Postal Address: Fisher & Paykel Appliances Limited, Pheasant Oak Barn, Hob Lane, Balsall Common, CV7 7GX

In Ireland if you need assistance...*

Phone: 01800 625 174

Fax: 01800 635 012

Email: customer.care@fisherpaykel.ie

Postal Address: Fisher & Paykel Appliances Limited, Unit 3, North Park, North Road, Dublin 11

For the rest of the world...*

Call your Fisher & Paykel retailer/dealer from whom you purchased the product. They are trained to provide information on your appliance. If we can be of any further help, please contact us on:

Phone: +64 9 273 0660

Fax: +64 9 273 0580

Email: international.enquiries@fp.co.nz

Postal Address: Fisher & Paykel Appliances Limited, PO Box 58550, Greenmount, Auckland, New Zealand

**Feel free to contact us at our website on
www.fisherpaykel.com**

*If you call or write, please provide: name, address, model number, serial number, date of purchase and a description of the problem. This information is needed in order to better respond to your request for assistance.

Product details

Fisher & Paykel Appliances Ltd

Model/Serial No.

Date of Purchase _____ **Purchaser** _____

Dealer _____ **Suburb** _____

Town _____ **Country** _____

State of California
Department of Health Services
Water Treatment Device
Certificate Number

06 - 1806

Date Issued: July 18, 2006

Trademark/Model Designation

Fisher & Paykel 836860

Replacement Elements

836848

Manufacturer: Cuno Incorporated

The water treatment device(s) listed on this certificate have met the testing requirements pursuant to Section 116830 of the Health and Safety Code for the following health related contaminants:

Microbiological Contaminants and Turbidity

Cysts
Turbidity

Inorganic/Radiological Contaminants

Asbestos
Lead
Mercury

Organic Contaminants

Atrazine
Benzene
Carbofuran
Lindane
p-dichlorobenzene
Toxaphene

Rated Service Capacity: 750 gal

Rated Service Flow: 0.78 gpm

Conditions of Certification:

Do not use where water is microbiologically unsafe or with water of unknown quality, except that systems certified for cyst reduction may be used on disinfected waters that may contain filterable cysts.

Performance Data Sheet For Fisher & Paykel Filter System Model: 836860

Replacement Cartridge: 836848

This system has been tested according to NSF/ANSI 42 and 53 for the reduction of the substances listed below. The concentration of the substances in water entering the system was reduced to a concentration less than or equal to the permissible limit for water leaving the system as specified in NSF/ANSI 42 & 53. Note that while the testing was performed under standard laboratory conditions, actual performance may vary.



System tested and certified by NSF International against NSF/ANSI Standard 53 for the reduction of Asbestos, Atrazine, Benzene, Cyst, Carbofuran, Lead, Lindane, Mercury, P-Dichlorobenzene, Toxaphene and Turbidity; against Standard NSF/ANSI 42 for the reduction of Chlorine Taste and Odor and Nominal Particulate Class 1.

To a capacity of 2,838 liters (750 gallons)

Substance	USEPA MCL	Influent Challenge concentration (mg/L)	Standard 53: Health Effects		Effluent		% Reduction		Min. Required Reduction
			Average	Maximum	Average	Maximum	Average	Maximum	
Turbidity	1 NTU**	11±1 NTU**	10.7 NTU**	0.49 NTU**	0.31 NTU**	95.20%	95.20%	97.09%	0.5 NTU**
Cysts	99.95% reduction	Minimum 50,000 #L 10 ⁷ to 10 ⁸ fibers/L;	166500 #L	<1 #L	<1 #L	<99.99%	<99.99%	<99.99%	>99.95%
Asbestos	99% reduction	fibers greater than 10 um in length	155 MF/L	<1 MF/L	<1 MF/L	<99.99%	<99.99%	<99.99%	>99%
Lead @ pH 6.5	0.015 mg/L	0.15mg/L ±10%	0.153 mg/L	<0.001 mg/L	<0.001 mg/L	99.35%	99.29%	99.35%	0.010 mg/L
Lead @ pH 8.5	0.015 mg/L	0.15mg/L ±10%	0.150 mg/L	<0.001 mg/L	<0.001 mg/L	99.33%	99.29%	99.33%	0.010 mg/L
Mercury @ pH 6.5	0.002 mg/L	0.006mg/L ±10%	0.006 mg/L	0.0003 mg/L	0.0003 mg/L	95.70%	90.91%	95.70%	0.002 mg/L
Mercury @ pH 8.5	0.002 mg/L	0.006mg/L ±10%	0.006 mg/L	0.0008 mg/L	0.0008 mg/L	86.22%	75.31%	86.22%	0.002 mg/L
Atrazine	0.003 mg/L	0.009mg/L ±10%	0.009 mg/L	<0.002 mg/L	<0.002 mg/L	76.99%	75.31%	76.99%	0.003 mg/L
Benzene	0.005 mg/L	0.015mg/L ±10%	0.014 mg/L	0.0006 mg/L	0.0011 mg/L	95.71%	92.14%	95.71%	0.005 mg/L
Carbofuran	0.04 mg/L	0.08mg/L ±10%	0.081 mg/L	<0.001 mg/L	<0.001 mg/L	98.74%	98.46%	98.74%	0.04 mg/L
p-dichlorobenzene	0.075 mg/L	0.225mg/L ±10%	0.208 mg/L	<0.0005 mg/L	<0.0005 mg/L	99.76%	99.74%	99.76%	0.075 mg/L
Lindane	0.0002 mg/L	0.002mg/L ±10%	0.002 mg/L	0.000025 mg/L	0.00007 mg/L	98.72%	96.50%	98.72%	0.0002 mg/L
Toxaphene	0.003 mg/L	0.015±10%	0.015 mg/L	<0.001 mg/L	<0.001 mg/L	92.97%	91.67%	92.97%	0.003 mg/L

Standard 42: Aesthetic Effects

Substance	USEPA MCL	Influent Challenge concentration (mg/L)	Effluent		% Reduction		Min. Required Reduction
			Average	Maximum	Average	Maximum	
Chlorine Taste & Odor	~	2.0mg/L ±10%	1.88 mg/L	0.0513666364 mg/L	0.06 mg/L	97.26%	96.84%
Nominal Particulate*	~	at least 10,000 particales/mL	5,700,000 #/ml	30,583 #/ml	69,000 #/ml	99.95%	98.94%

* Measurement in Particles/ml. Particles used were 0.5 - 1 microns.

**NTU = Nephelometric Turbidity Units

Operation Specifications	
Water pressure	172-827 kPa (25-120psi)
Water temperature	0.6-38°C (33-100°F)
Service flow	2.9 lpm (.78 gpm)
Filter capacity	2,838 liters (750gallons)

Systems must be installed and operated in accordance with manufacturer's recommended procedures and guidelines. Follow any and all local plumbing codes and requirements. Some local codes may require the use of a licensed plumber or a certified installer when disrupting a potable water line.

Important: Failure to follow instructions may result in voidance of warranty.

© 3M Company. All rights reserved.
INSTR7069 0706

IMPORTANT: Change the filter cartridge at least every 6 months.

CAUTION: To reduce the risks associated with water leakage, which, if not avoided, may result in property damage - check with your plumbing professional to verify that water pressure is less than 827 kPa (120 psi).

For estimated cost of replacement element, please call 1-888-936-7872 or contact your local appliance distributor or dealer.



Manufactured by : CUNO Incorporated, a 3M Company
1000 Apollo Road
Eagan, MN 55121

Copyright © Fisher & Paykel 2007. All rights reserved.

The product specifications in this booklet apply to the specific products and models described at the date of issue. Under our policy of continuous product improvement, these specifications may change at any time. You should therefore check with your Customer Care Centre to ensure this booklet correctly describes the product currently available.

www.fisherpaykel.com

NZ AU GB AE HK SG IE

Ice & Water refrigerator

Installation instructions and user guide

Published: 01/2007

Part No. 818596 B