

*Frigidaire*

Factory Parts Catalog

Product No.	PLEB30T9FCA
	37057363H60S1
Series	30" double
Color	stainless
Market	North America
Wiring Diagram	318046121
Owner's Guide	318200943
Installation Instructions	318201514
Service Data Sheet	318047306
Timer Guide	318200135

 **Electrolux**

Electrolux Major Appliances  
North & Latin America  
P.O. BOX 212378  
AUGUSTA, GA 30917

Publication No.  
**5995469029**  
06/06/28  
(EN/SERVICE/ECL)  
377

**DOUBLE ELECTRIC  
WALL OVEN**

Model No.  
**PLEB30T9F**

Copyright © 2006 Electrolux Home Products, Inc.  
All rights reserved.

**CONTROL PANEL**

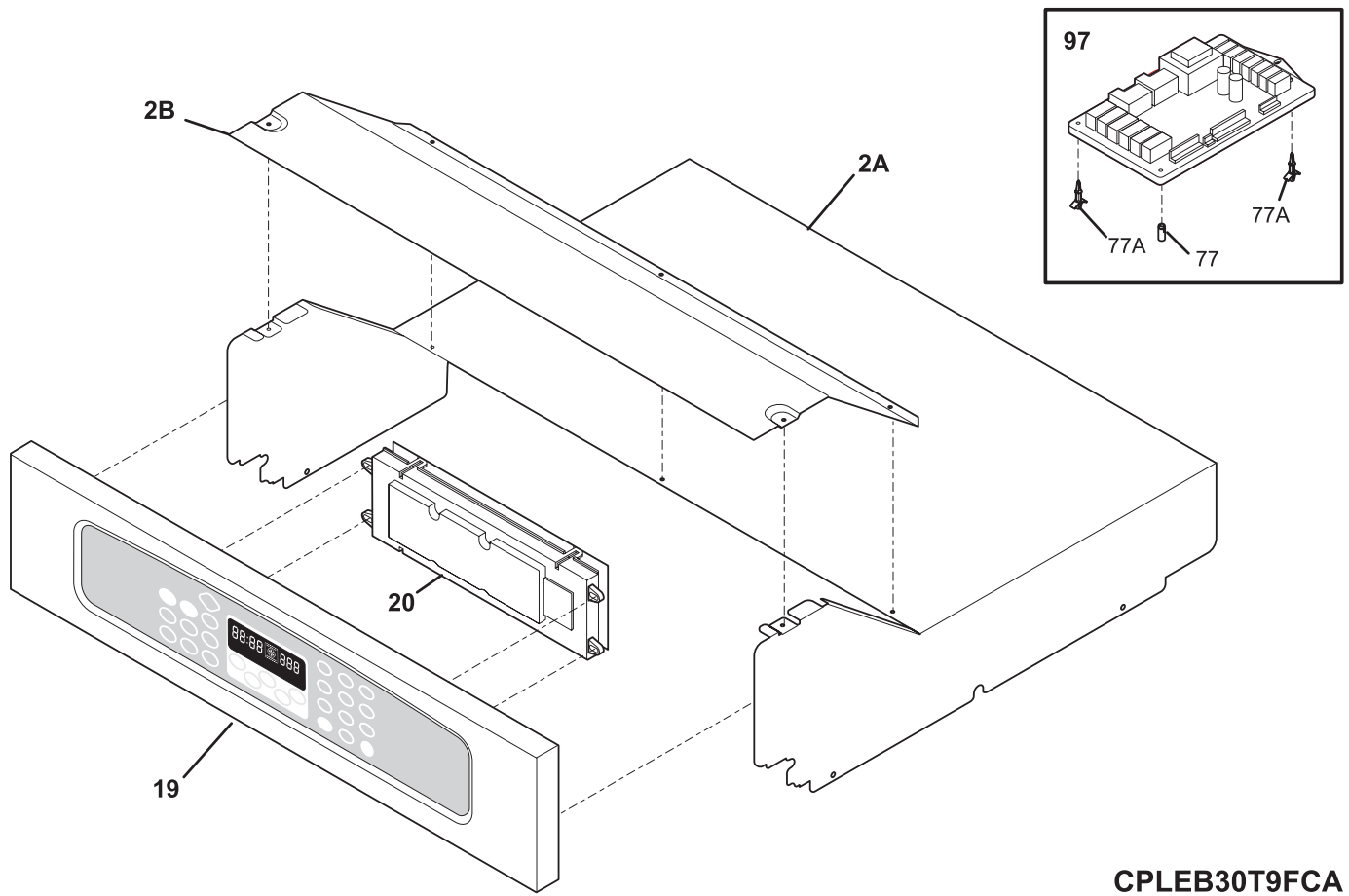

**CPLEB30T9FCA**

**CONTROL PANEL**

---

POS. NO	PART NO.	DESCRIPTION
2A	318257300	Shield, oven top
2B	318260100	Cover, box
19	318271534	Control Panel Assembly, steel/glass, stainless/black, w/touch pad
20 #	316443805	Control, electronic, ES610W3, dual oven
*	5303311306	Screw, 8-18 x 0.375, (3)
77	316247900	Spacer, power board, (2)
77A	316114100	Spacer, (2)
97	316443901	Board, relay, dual oven
*	318231751	Harness, wiring, control-relay
*	5303211311	Screw, 8 x 0.500

UPPER OVEN

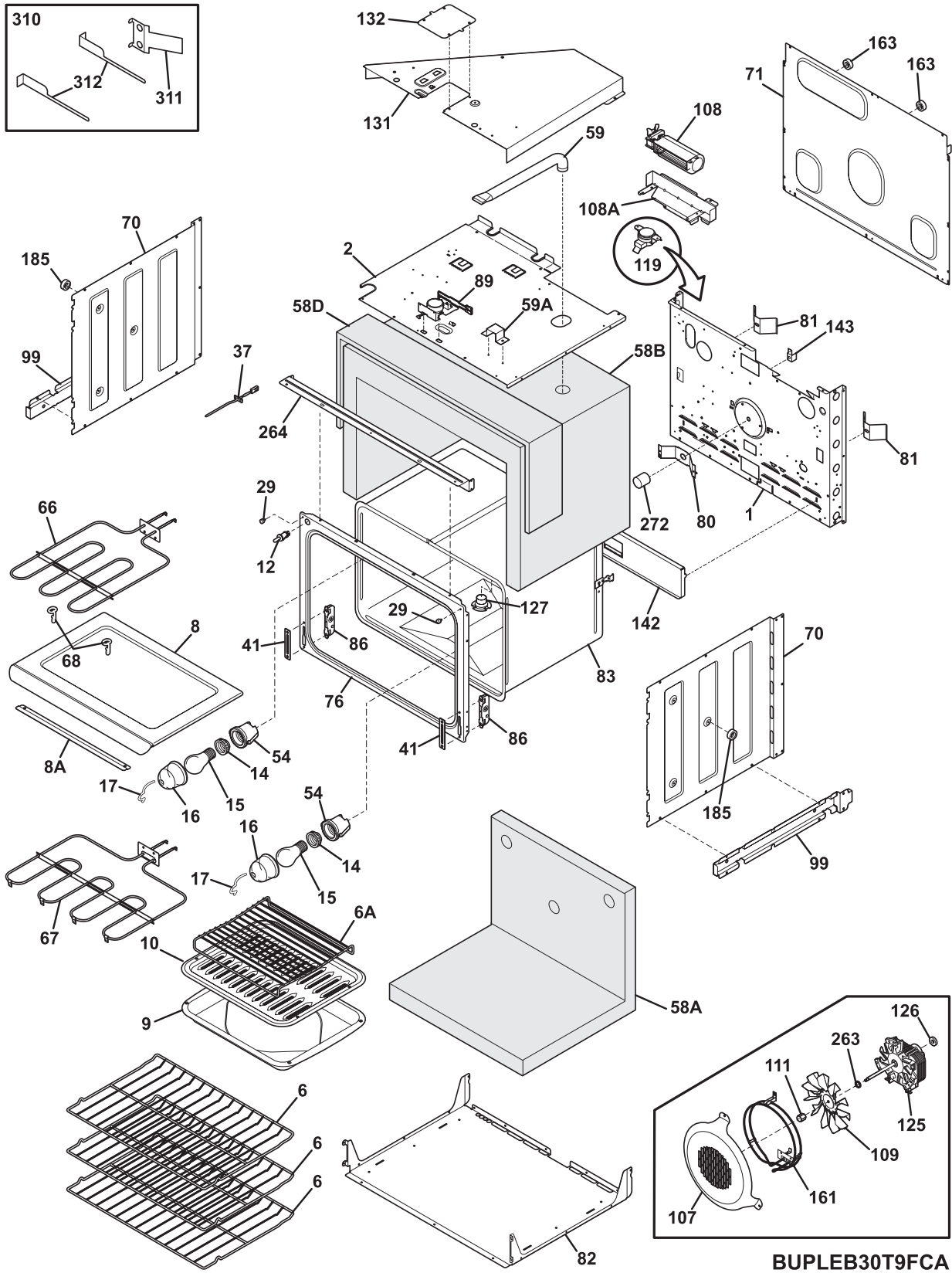

BUPLEB30T9FCA

---

**UPPER OVEN**

---

POS. NO	PART NO.	DESCRIPTION
1	318259204	Back, main
2	318258902	Shield, insulation, upper
6	318345208	Rack, oven
6A	318219500	Rack, broiler pan
8	318262001	Cover, element
8A	318318600	Bracket, element, hidden bake
9	5303317977	Pan, broiler
10	5303317976	Insert, broiler pan
12 #	318089917	Switch, light
14	318224000	Receptacle, oven light
14*	318268099	Insulation, oven light
15	5303013071	Bulb/Lamp, light
16	3201911	Cover, oven light, glass
17	5304400195	Retainer, light cover
29	318147411	Bumper, (2)
37 #	316217002	Probe, oven temp
41	5303310526	Cover, hinge cutout
54	318222400	Housing, oven light
58A	318285055	Insulation, oven wrapper
58B	318285056	Insulation, oven back
58D	318133789	Insulation, 1/2" thick, 26.75 x 19
*	318294903	Insulation, 9.5x26.75x.5
58D	318285058	Insulation, 1/2" thick, 43 x 9.5
59	318072560	Duct, oven vent
59A	318261600	Bracket, vent tube
66 #	318255600	Element, broil, 2750W
67	318254901	Element, bake, 3400W, 8 pass
68	5304403015	Support, hanger, (2), broil element
70	318259100	Shield, insulation, sides, (2)
71	318260007	Panel, rear box
71*	318340200	Bracket, insul. panel
76	318056217	Front, oven
80	5303320846	Plate, oven mtg
81	318192400	Spring, oven
82	318258707	Shield, insulation, lower
83	318261400	Liner, oven assy
86	5303310524	Receptacle, hinge
89 #	318261211	Motor, latch assy
* #	318231750	Harness, wiring, main, latch
* #	318199744	Wiring Harness, latch, BAS
* #	318199746	Wiring Harness, latch, NO BAS
99	318252800	Support, side
*	5303300265	Screw, 8-18 X 1/2, (2)
107	318219401	Cover, fan
108#	318073018	Motor, blower
*	08016432	Screw, truss head, 8-18 x 0.375
108A	318251300	Bracket, fan support
109	316136400	Blade, fan
111	316136600	Nut, fan retainer
119#	318004900	Switch, thermal
125#	316415800	Motor, fan
125*	5303316994	Insulation, 3.81 x 3.13
126	318142100	Washer, motor, RH, convection
127	318317100	Adapter Assembly, vent tube, w/converter
131	318272900	Box, vent
132	318003000	Plate, shield
142	318123910	Deflector
143	318172904	Support, wire
161#	318255503	Element, convection, 350 W
163	318014111	Spacer
185	318014700	Spacer, oven shield, (4)
263	316136500	Washer, flat
264	318257701	Trim, oven, black, front
272	318249401	Tube, protector
310	5304440067	Cabinet Mounting Kit
311	318246010	Bracket, cabinet mtg. (2)
311*	5304438005	Screw, 6 x 1, black
312	318246702	Tool, cabinet bracket, RH
312	318246703	Tool, cabinet bracket, LH
*	318165800	Spacer
*	5303211311	Screw, 8 x 0.500
*	5303323277	Screw, 8-18 X 13/32
*	5304436875	Screw, 8-18 X 1/2, black

LOWER OVEN

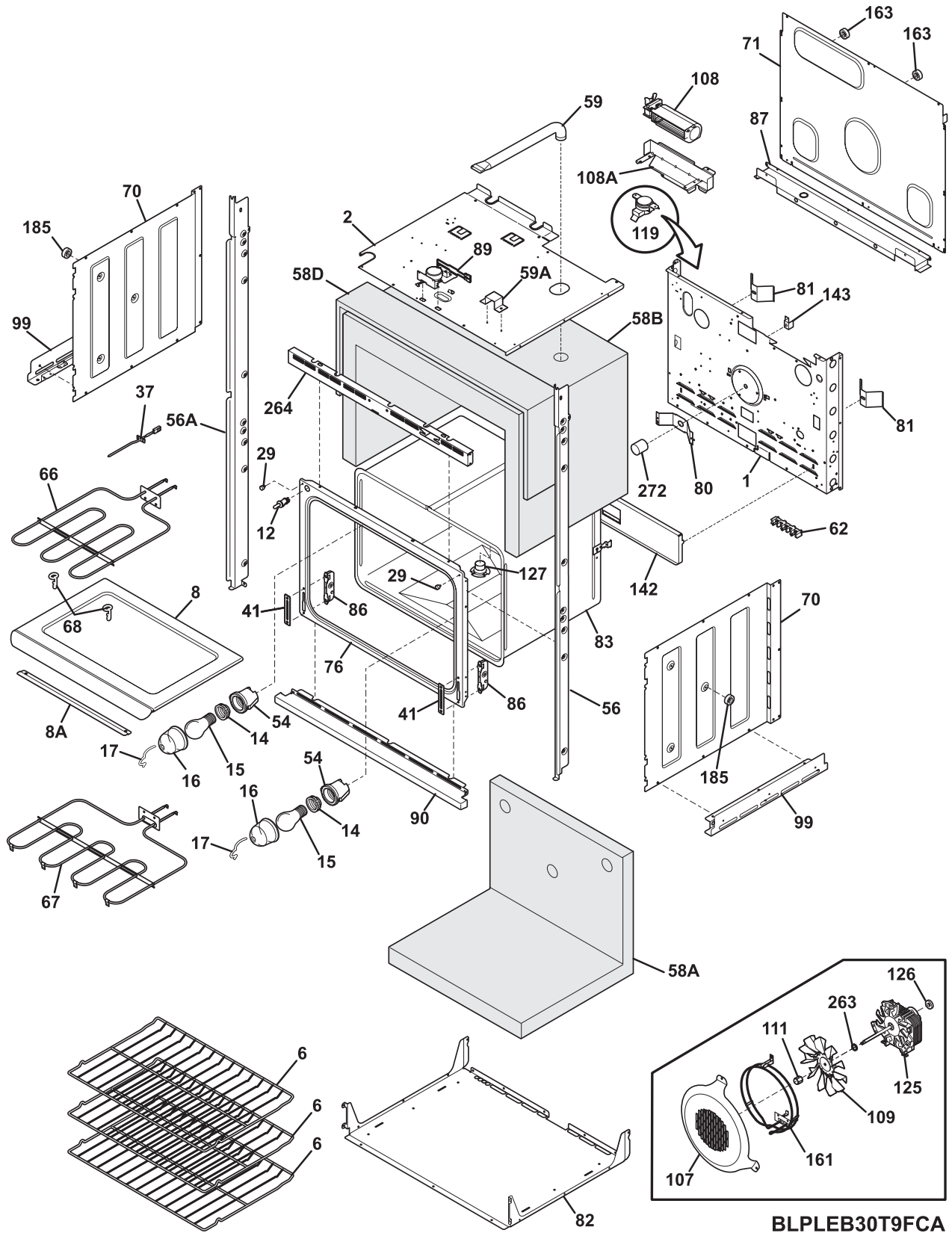

---

**LOWER OVEN**

---

POS. NO	PART NO.	DESCRIPTION
1	318259204	Back, main
2	318258902	Shield, insulation, upper
6	318345208	Rack, oven
8	318262001	Cover, element
8A	318318600	Bracket, element, hidden bake
12 #	318089917	Switch, light
14	318224000	Receptacle, oven light
14*	318268099	Insulation, oven light
15	5303013071	Bulb/Lamp, light
16	08011086	Lens, oven light, glass
17	5304400195	Retainer, light cover
29	318147411	Bumper, (2)
37 #	316217002	Probe, oven temp
41	5303310526	Cover, hinge cutout
54	318222400	Housing, oven light
56	318259914	Trim, side filler, black, RH
56A	318259915	Trim, side filler, black, LH
58A	318285055	Insulation, oven wrapper
58B	318285056	Insulation, oven back
58D	318285058	Insulation, 1/2" thick, 43 x 9.5
59	318072560	Duct, oven vent
59A	318261600	Bracket, vent tube
62	316056000	Terminal Block
62*	5303323139	Screw, 10-24 x 0.906
62*	5303323144	Nut, 10-32
66 #	318255600	Element, broil, 2750W
67	318254901	Element, bake, 3400W, 8 pass
68	5304403015	Support, hanger, (2), broil element
70	318259100	Shield, insulation, sides, (2)
71	318260007	Panel, rear box
71*	318340200	Bracket, insul. panel
76	318056217	Front, oven
80	5303320846	Plate, oven mtg
81	318192400	Spring, oven
82	318258707	Shield, insulation, lower
83	318261400	Liner, oven assy
86	5303310524	Receptacle, hinge
87	318260600	Bracket, cable mtg.
89 #	318261211	Motor, latch assy
* #	318231750	Harness, wiring, main, latch
* #	318199744	Wiring Harness, latch, BAS
* #	318199746	Wiring Harness, latch, NO BAS
90	318259803	Trim, base, stainless
99	318256200	Bracket, side, bottom, (2)
*	5303300265	Screw, 8-18 X 1/2, (2)
107	318219401	Cover, fan
108#	318073018	Motor, blower
*	08016432	Screw, truss head, 8-18 x 0.375
108A	318251300	Bracket, fan support
109	316136400	Blade, fan
111	316136600	Nut, fan retainer
119#	318004900	Switch, thermal
125#	316415800	Motor, fan
125*	5303316994	Insulation, 3.81 x 3.13
126	318142100	Washer, motor, RH, convection
127	318317100	Adapter Assembly, vent tube, w/converter
142	318123910	Deflector
143	318172904	Support, wire
161#	318255503	Element, convection, 350 W
163	318014111	Spacer
185	318014700	Spacer, oven shield, (4)
263	316136500	Washer, flat
264	318257801	Trim, oven, black, front
272	318249401	Tube, protector
* #	318078543	Box & wires assy
*	318231748	Harness, wiring, main
*	5303323136	Screw ground
*	5303211311	Screw, 8 x 0.500
*	5303323277	Screw, 8-18 X 13/32
*	5304436875	Screw, 8-18 X 1/2, black

DOORS

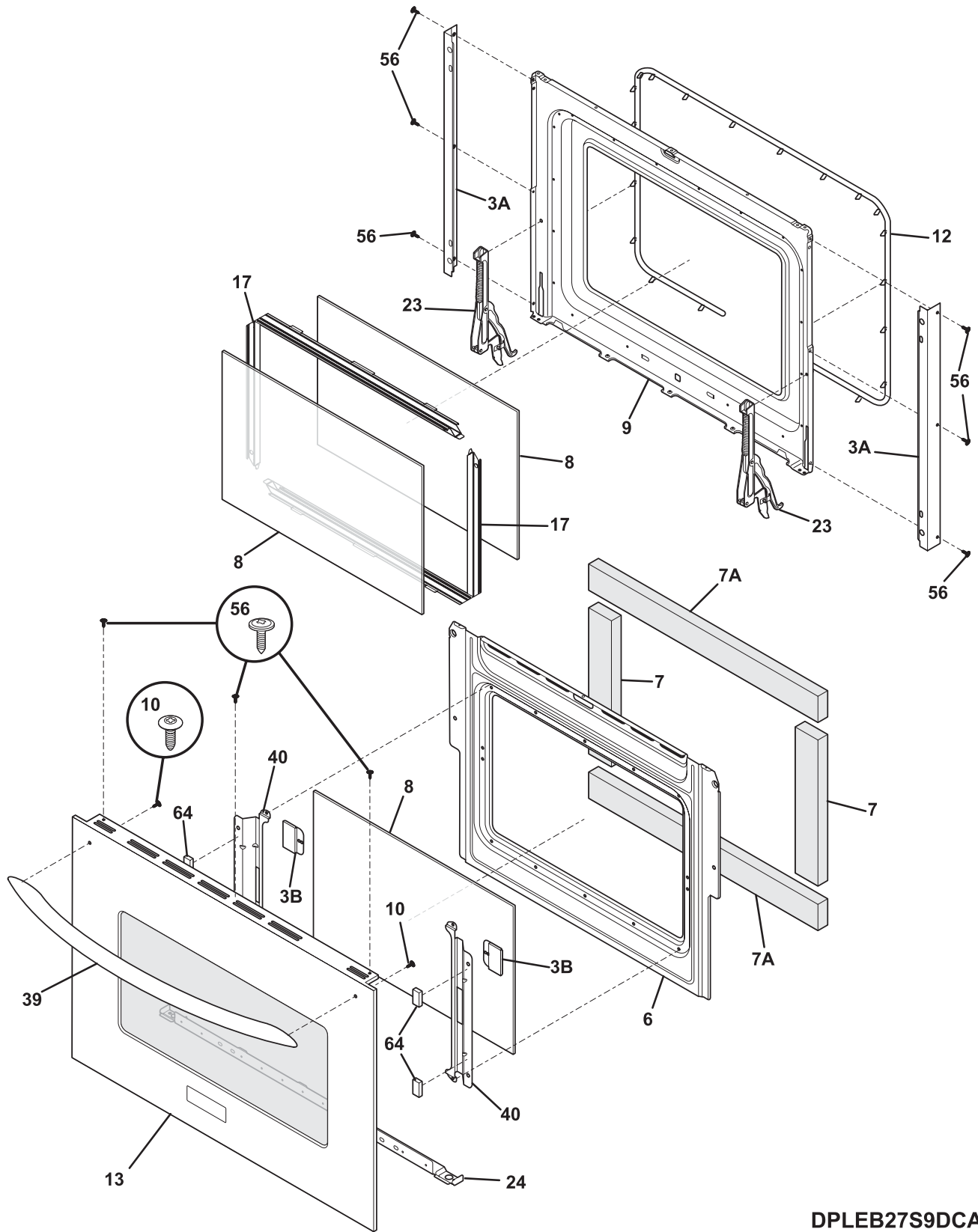

DPLEB27S9DCA



## DOORS

---

POS. NO	PART NO.	DESCRIPTION
3A	318260401	Trim, oven door, side, (2)
3B	318262101	Cover, rear door, black, (2)
6	318260520	Baffle, door
7	318285057	Insulation, oven door
7A	318285062	Insulation, oven door
8	316117500	Glass, oven door, heat barrier
9	318259605	Liner, door
10	5303311174	Screw, 10-24 x 3/8
12	318053130	Seal, oven door, upper
12	318053120	Seal, door, lower oven
13	318272166	Door Assy, glass, stainless steel, outer
13	318272167	Door Assy, w/nameplate, stainless steel, outer, w/tape & foil
17	316402403	Spacer, door glass, (2)
23	318024714	Hinge, door, (2)
24	318260301	Trim, door, black, lower
39	318219802	Handle, door/drawer, stainless
40	318242700	Bracket, glass holder, (2)
56	5304436875	Screw, 8-18 X 1/2, black
64	318165800	Spacer
*	5303323277	Screw, 8-18 X 13/32

WIRING DIAGRAM

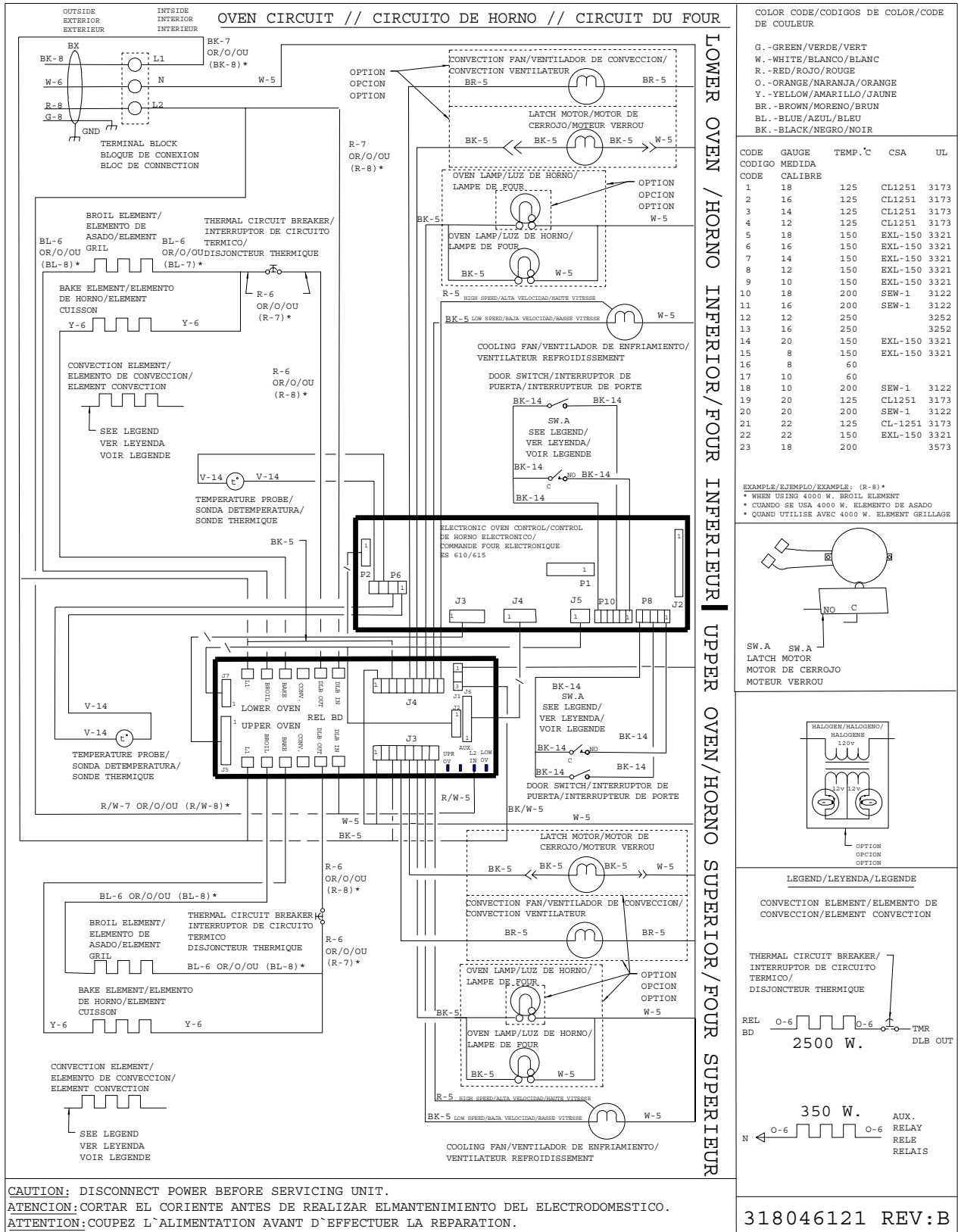

COLOR CODE/CODIGOS DE COLOR/CODE DE COULEUR

G. -GREEN/VERDE/VERT  
W. -WHITE/BLANCO/BLANC  
R. -RED/ROJO/ROUGE  
O. -ORANGE/NARANJA/ORANGE  
Y. -YELLOW/AMARILLO/JAUNE  
BR. -BROWN/MORENO/BRUN  
BL. -BLUE/AZUL/BLEU  
BK. -BLACK/NEGRO/NOIR

CODE	GAUGE	TEMP. °C	CSA	UL
CODIGO	MEDIDA			
CODE	CALIBRE			
1	18	125	CL1251	3173
2	16	125	CL1251	3173
3	14	125	CL1251	3173
4	12	125	CL1251	3173
5	18	150	EXL-150	3321
6	16	150	EXL-150	3321
7	14	150	EXL-150	3321
8	12	150	EXL-150	3321
9	10	150	EXL-150	3321
10	18	200	SEW-1	3122
11	16	200	SEW-1	3122
12	12	250		3252
13	16	250		3252
14	20	150	EXL-150	3321
15	8	150	EXL-150	3321
16	8	60		
17	10	60		
18	10	200	SEW-1	3122
19	20	125	CL1251	3173
20	20	200	SEW-1	3122
21	22	125	CL-1251	3173
22	22	150	EXL-150	3321
23	18	200		3573

EXAMPLE/EJEMPLO/EXAMPLE: (R-8)\*  
\* WHEN USING 4000 W. BROIL ELEMENT  
\* CUANDO SE USA 4000 W. ELEMENTO DE ASADO  
\* QUAND UTILISE AVEC 4000 W. ELEMENT GRILLAGE

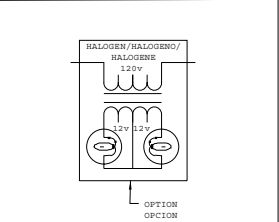
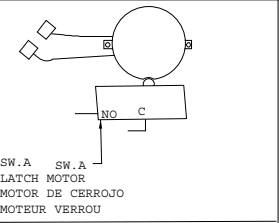

LEGEND/LEYENDA/LEGENDE  
CONVECTION ELEMENT/ELEMENTO DE CONVECCION/ELEMENT CONVECTION

