

Frigidaire

Factory Parts Catalog

Product No.	GLGT1031CS1
Market	North America
Color	white
Volts	120
Wiring Diagram	134134100
Owner's Guide	131781700
Installation Instructions	131661700
Operating Instructions	134089600
Operating Instructions	131921300
Energy Guide	134355900

 **Electrolux**

ELECTROLUX HOME PRODUCTS, INC.
P.O. Box 212378, Augusta, GA 30917

Publication No.
5995410288
04/05/20
(EN/SERVICE/WC)
361

**LAUNDRY CENTER
WITH GAS DRYER**

Model No.
GLGT1031C

Copyright © 2004 Electrolux Home Products, Inc.
All rights reserved.

UPPER CABINET/DRUM HEATER

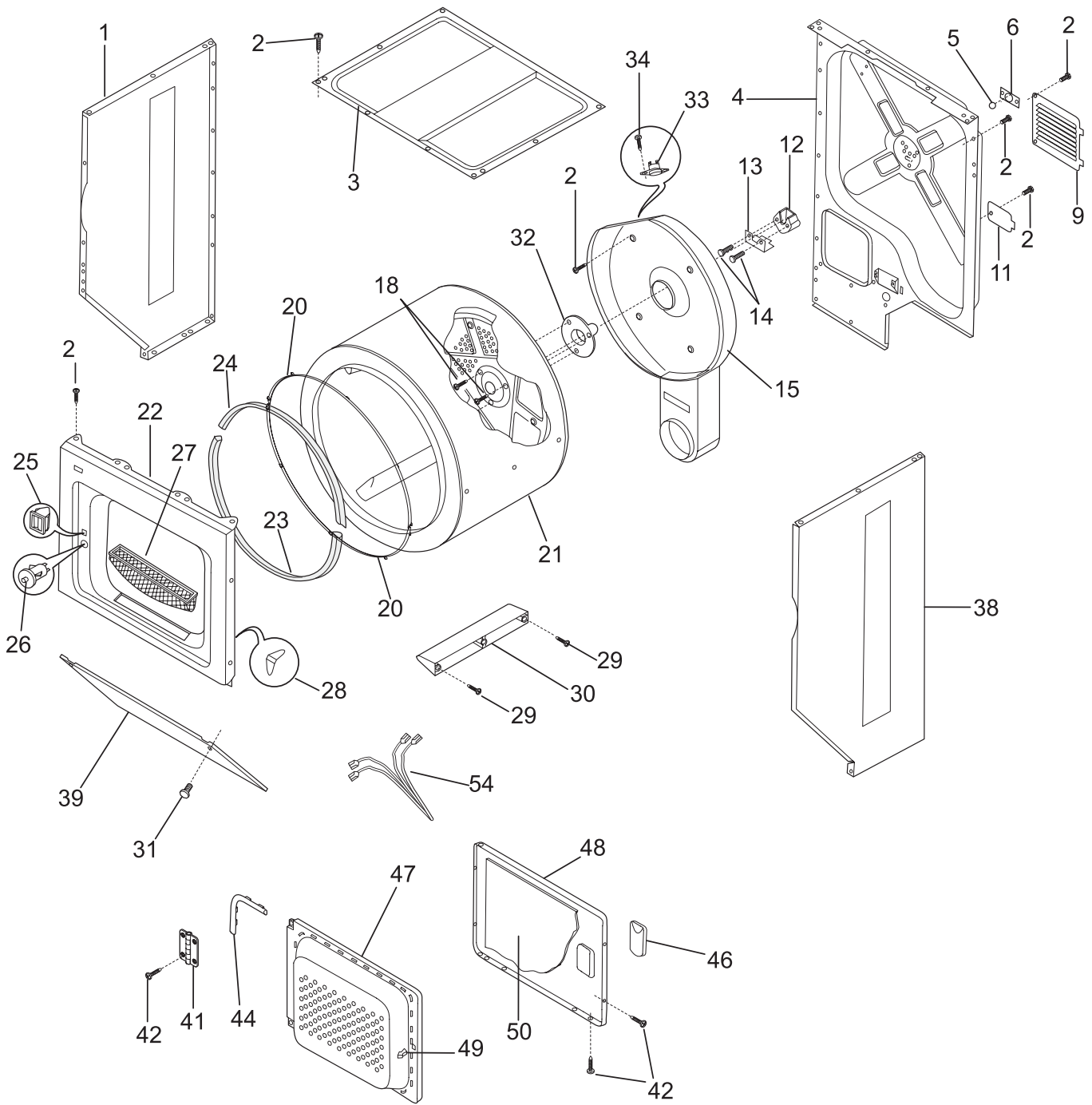

P17U0038

UPPER CABINET/DRUM HEATER

POS. NO	PART NO.	DESCRIPTION
1	131084710	Panel, white, left side
2	131168200	Screw, pan head, 8-18B x 0.31
3	131883301	Panel, top
4	131752302	Panel, rear, steel, galvanized
5	5303281019	Ball
6	5303281020	Clip, ball, steel, flat nut
9	3204249	Panel, motor access, rear
11	5303207395	Cover, terminal block
12	131825900	Bearing, drum support
13	131724300	Bracket, bearing support
14	131205400	Screw, bracket mtg., 10-16B x 1.375, cr/sq drive
15	5303207394	Housing, heater, w/duct & seal
18	131477000	Screw, 10-16AB x 0.375
20	131963900	Glide, drum
21	134122572	Drum, dryer, painted, service kit
22	134031600	Panel, front, white, svce kit w/plug
22*	131870700	Plug, light hole
23	134134700	Seal, felt, lower
24	134036400	Seal, felt, upper
25	131658800	Door Catch
26 #	5308001614	Switch, door, w/o drum light
27	131359600	Lint Trap
28	5303281074	Clip, guide, (3)
29	131382300	Screw, quadrex head, 10-14 x 1.00, vane mtg., special
30	5303201200	Vane, straight
31	131202300	Screw, pph, 10-16AB x 0.625
32	131777700	Shaft, drum support, ballhitch
33 #	5304406099	Thermostat, safety
34	131243800	Screw, pan hd locking, 8-32CA x 0.375, cup point
38	131084810	Panel, white, right side
39	131084402	Panel, access, white, front
41	134222900	Hinge, dryer door
42	131209600	Screw, flat head, 8-18AB x 0.44, cr/sq drive
44	131129900	Gasket, door seal
46	131789400	Handle, door, white
47	131579103	Panel, inner door, white
48	131789303	Panel, outer door, white
49	5303211430	Door Strike
50	3204286	Insulator, heat shield, outer door
54 #	131498900	Wiring Harness, door switch, w/o light

MOTOR/BLOWER/BELT

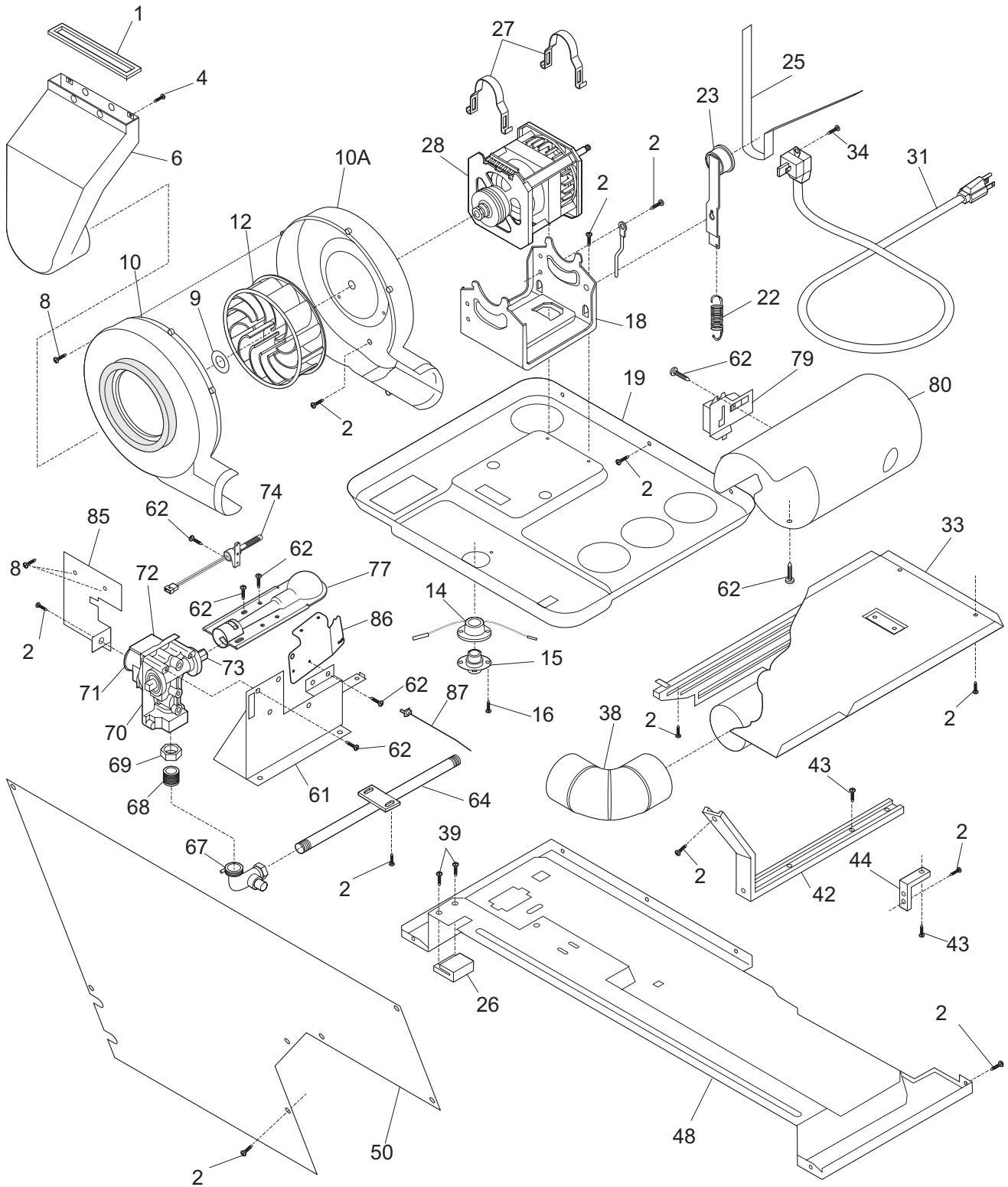

P17B0041

MOTOR/BLOWER/BELT

POS. NO	PART NO.	DESCRIPTION
1	131295200	Seal, air duct
2	131168200	Screw, pan head, 8-18B x 0.31
4	131362400	Fastener, push-in
6	134086300	Duct, air
8	3205245	Screw, pan head, 6-18AB x 0.60
9	5303304824	Clamp
10	131784500	Housing, blower, front, with seal
10A	134145100	Housing, blower, rear
12	131476300	Blower Wheel
14 #	131658101	Thermostat, heater
15 #	131322600	Thermostat, control
16	131311900	Screw, quadrex ph, 8-18AB x 0.500
18	131413600	Cradle, motor mount, with idler stud
19	131363901	Panel, motor cradle mt
22	3205241	Spring, idler
23	131863100	Idler Arm Assy, with pulley
25 #	134163500	Belt, dryer drive
26	5303212870	Block, support, bottom panel
27	134242400	Clamp, motor mtg.
28 #	134196600	Motor, dryer drive, with pulley
31 #	134099900	Power Cord, electric svce
33	131731410	Shield, access area, cover
34	134154100	Screw, hex washer head, 10-32 x 0.375, ground
38	3204320	Elbow, exhaust duct
39	131205100	Screw, #8 pan head, 10-10B x 0.500, cr/sq drive
42	5304439185	Bracket, marriage, interior
43	131751500	Screw, hex head, 12-24T 0.63
44	3204326	Bracket, L mounting, cabinet rear, external
48	131731310	Panel, dryer, bottom rear
50	3204329	Cover, safety, lower front
61	5303309493	Bracket, gas valve mtg
62	131243700	Screw, pan head, 8-18AB x 0.375, cr/sq drive
64	134145200	Pipe, gas
67 #	131498500	Valve, gas shutoff
68 #	134185100	Tail Piece, coupling
69 #	5308015194	Union, hex nut
70 #	5303207409	Valve, gas
71 #	5300622602	Solenoid, secondary coil
72 #	5308015680	Solenoid, booster coil
73 #	5303211036	Orifice, natural gas, size 44
74 #	134393700	Igniter Assy
77 #	134197700	Burner, gas
79 #	5303281135	Sensor, radiant
80 #	131712401	Tube, burner
85	134287300	Shield, heat
86	134264800	Plate, adapter
87	131964400	Cable Tie, push mount, 5.20 inch
* #	134391000	LP Conversion Kit, natural to LP
* #	134101400	Terminal Block, main

CONTROL PANEL

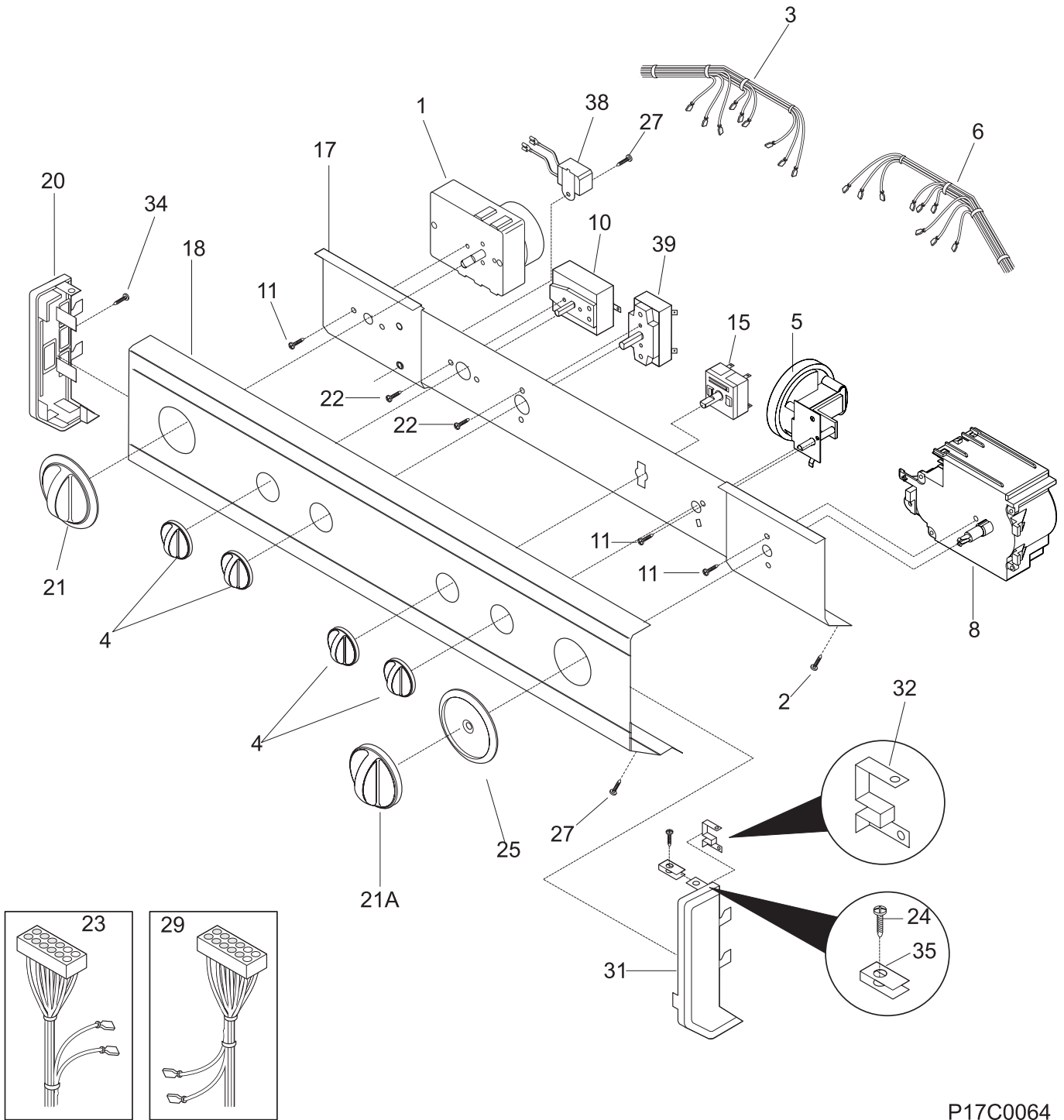

P17C0064

CONTROL PANEL

POS. NO	PART NO.	DESCRIPTION
1	131583801	Timer, dryer, 3-off
2	131168200	Screw, pan head, 8-18B x 0.31
3 #	131703600	Wiring Harness, dryer control
4	134034950	Knob, rotary, white
5	131692100	Switch, pressure, 3 position, 1/2 hp
5*	131209800	Clamp, hose, pressure switch
6 #	134122200	Wiring Harness, washer control, w/temp switch
8 #	134049600	Timer, washer
10 #	131447500	Switch, start, turn type
11	5303283289	Screw, cr pan head, 8-32 x 0.250, thread forming
15 #	131620800	Switch, temp selector, 3 posn rotary
17	134135100	Bracket, control mtg
18	134284200	Panel, trimplate, console front
20	131288101	End Cap, white, LH
21	134043000	Knob, dryer timer, white/dark gray
21A	134043200	Knob, washer timer, white
22	3161259	Screw, switch mtg, 6-32 x 0.19, (2), sems
23 #	131848700	Wiring Harness, main
* #	134101400	Terminal Block, main
24	131209600	Screw, flat head, 8-18AB x 0.44, cr/sq drive
25	131976804	Indicator, timer pointer, white/dark gray, washer
27	131892100	Screw, 6-20B x 0.230
29 #	134113400	Wiring Harness, washer, lower
29*	5303161300	Strap, plastic
31	131288211	End Cap, white, RH
32	3204357	Clip, grounding
34	131243700	Screw, pan head, 8-18AB x 0.375, cr/sq drive
35	5308014350	Clip, end cap mtg, U-type
38 #	5303286537	Buzzer
39	131753000	Switch, dryer temp, 4 posn rotary
*	134355900	Energy Guide, Laundry Center

LOWER CABINET/TOP

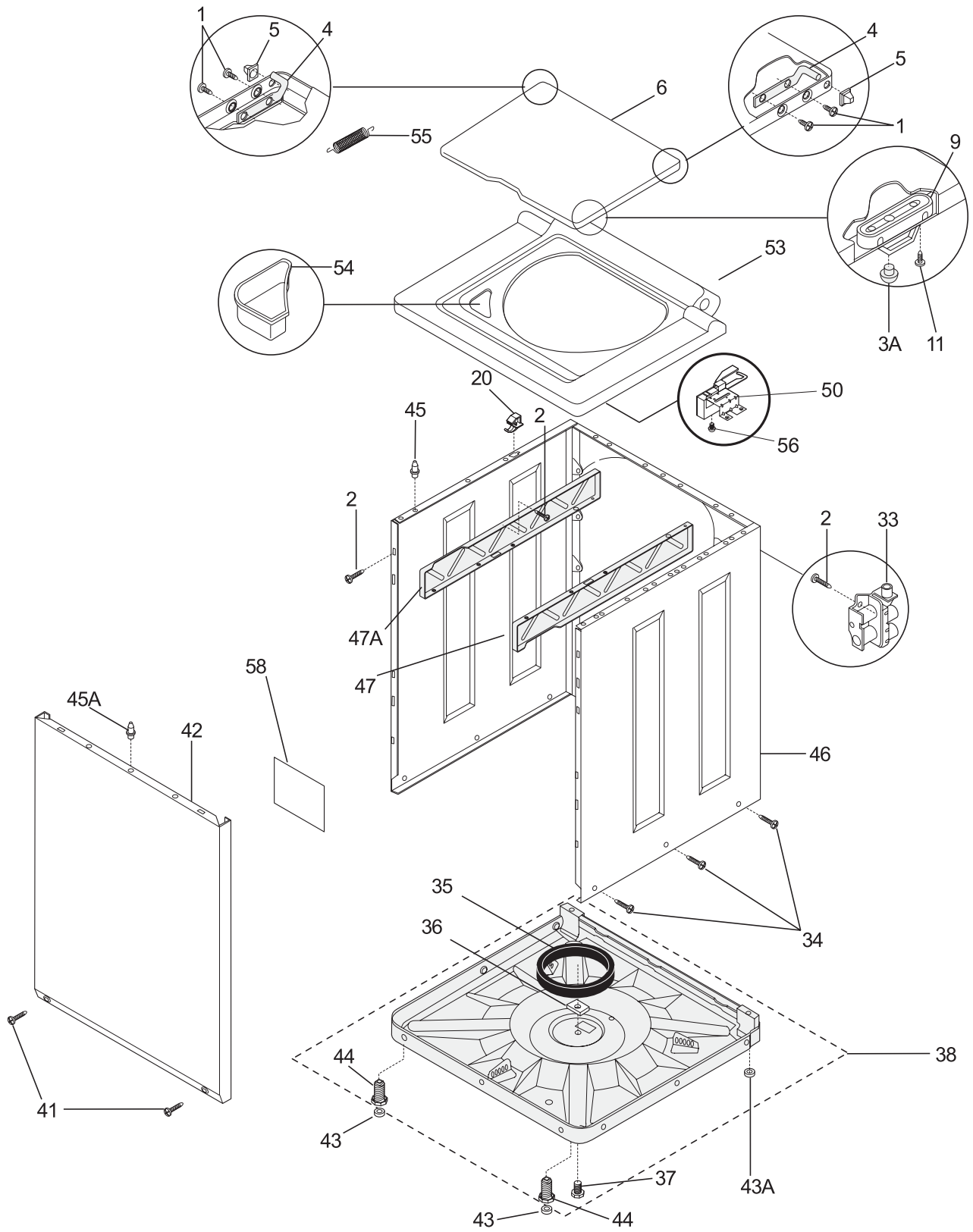

P17R0016

LOWER CABINET/TOP

POS. NO	PART NO.	DESCRIPTION
*	131453000	Bushing, snap-in, drain hose
*	5303212877	Insert, spring adjuster, vertical
*	5303309503	Clip, drain hose, back sheet
1	134203900	Screw, pan hd phillips, 6-32 x 0.337, dog point
2	131168200	Screw, pan head, 8-18B x 0.31
3A	134075500	Bumper, lid, front
4	3205250	Hinge Bar
5	5303208743	Grommet, hinge
6	5303212872	Lid, washer, white
9	131390000	Lid Strike
11	3204368	Screw, lid strike mtg, 6-20B X 0.375
20	3204374	Pin, slide, side to top
33 #	134211400	Valve, water, 115 V
34	131205500	Screw, cab body, 1/4-14 x 0.625, side-to-base
35	5308002385	Snubber Ring
36	3204380	Shipping Block
37	131658900	Screw, shipping, 1/4-20 x 1.001, yellow, unit base, thread forming
38	5303311213	Base Assembly
41	131258400	Screw, 10-16AB x 0.500
42	131104303	Panel, front, white
43	131422100	Pad, leveling leg, front
43A	131422200	Pad, self lvlg leg, rear
44	5303309673	Screw, leveling leg, with pad
45	131346400	Pin, panel locator, side
45A	131346401	Pin, panel locator, front
46	134046600	Cabinet Assy, white, back and sides
47	131106701	Bracket, marriage, RH
47A	131091001	Bracket, marriage, LH
50 #	134101800	Lock, lid, w/ext switch
53	131452510	Panel, washer top, white
54	3204394	Dispenser, bleach
55	5303212876	Spring, lid assist
56	131243700	Screw, pan head, 8-18AB x 0.375, cr/sq drive
58	131744202	Damper, vibration

MOTOR/TUB

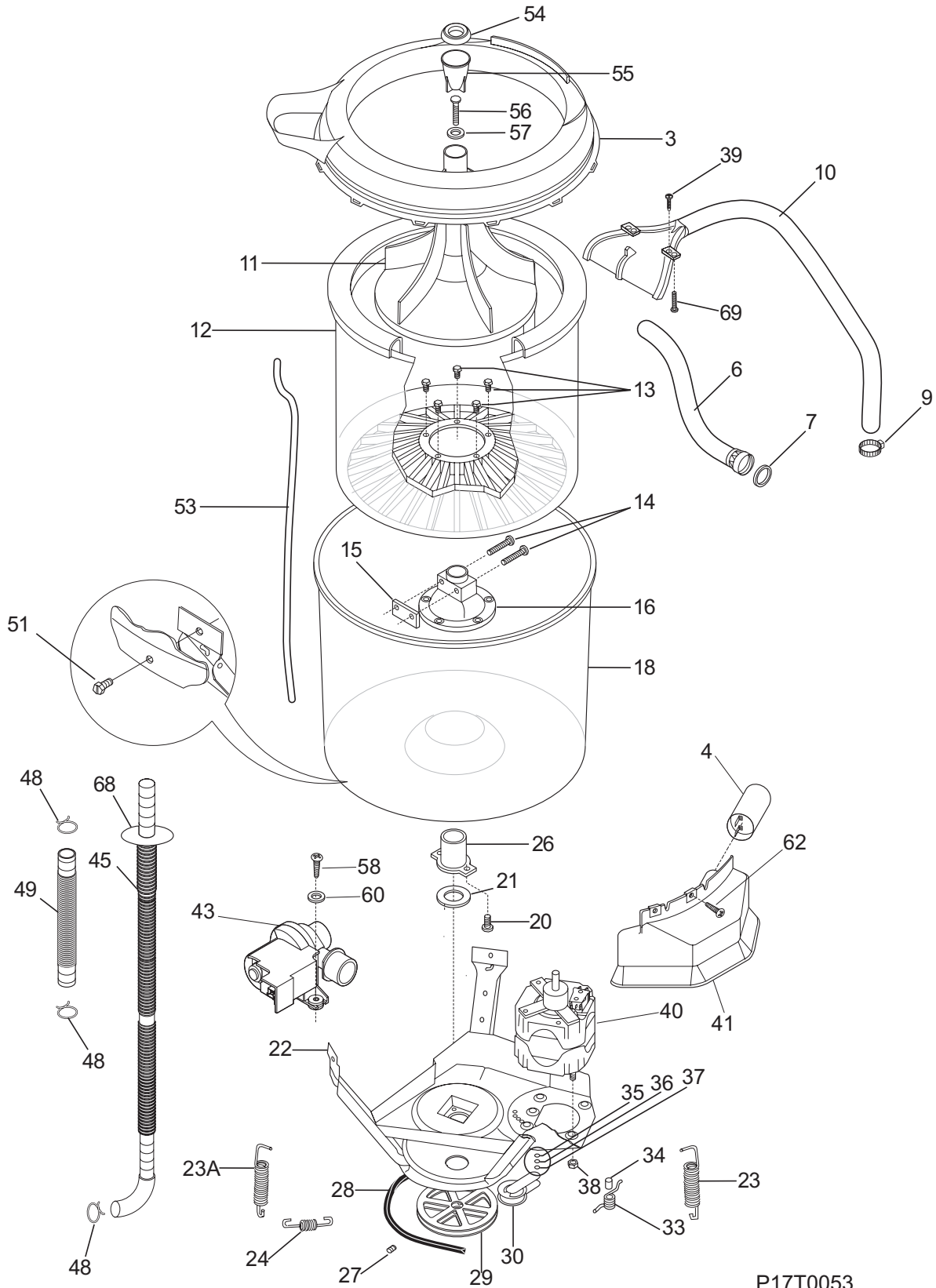

P17T0053

MOTOR/TUB

POS. NO	PART NO.	DESCRIPTION
3	131551102	Cover, splash tub, with seal
3*	131901400	• Seal, splash cover
4 #	131212301	Capacitor, motor
6	131454100	Hose, water inlet, 4 ft., hose & washer
7	5303161296	Washer, inlet hose
9	5303304824	Clamp
10	131726300	Hose Assy, w/nozzle, clamp
11	131427200	Agitator
12	131221300	Tub, spin
13	5303283293	Screw, trunion, 5/16-18 x 0.625, (5)
14	131192800	Screw, lockplate, 5/16-18 x 1.625
15	5308001923	Plate, lock
16	131545101	Trunnion
18	131557201	Tub, splash, w/air dome, brg
20	3205150	Screw, tub bearing, 8-12B x 0.750
21	5308002401	Washer, spin bearing, upper
22	131373610	Leg & Dome Assy
23	5303208858	Spring, vertical, short
23*	5303212877	Insert, spring adjuster, vertical
23A	5303208860	Spring, vertical
24	131373900	Spring, horizontal
26 #	3204405	Bearing, outer tub
27	5303304825	Screw, set, hex hd cup, 5/16-18 x 0.85, xmsn pulley, hex head cup pt
28 #	134161100	V-Belt, washer drive, standard 4L
29 #	131498301	Pulley, xmsn drive
30 #	131862900	Idler Arm Assy, VAW, with pulley
33	3204425	Spring, torsional
34	3204426	Sleeve, idler pivot
35	3161433	Ring, retaining
36	5303261031	Washer, pivot shaft
37	5303161306	Washer, spring type
38	5303318708	Nut, hex flange, motor mounting
39	131205100	Screw, #8 pan head, 10-10B x 0.500, cr/sq drive
40 #	134159500	Motor, 3/4 hp, 2 speed, with pulley
41	131513300	Shield, motor assy, w/speed nuts
43 #	134051200	Pump, drain
45	134049200	Hose, drain
45*	131453000	Bushing, snap-in, drain hose
45*	131462500	Clip, drain hose, base
45*	131506500	Clip, drain hose, back sheet, (2)
45*	131663500	Cushion, drain hose, base
48	131306234	Clamp, pump to trap
49 #	131494800	Hose, pump to tub
51	134164400	Screw, hex washer head, 5/16-18 x 0.625
53	5304401845	Tube, pressure, vinyl
54	131266800	Cap, dispenser
55	131206100	Cup, dispenser
56	131468900	Screw, agitator mtg, 5/16-18 x 1.250
57	131339600	Spacer, agitator mtg, rubber
58	134160900	Screw, quadrex, 10-16AB X 0.750
60	131304300	Washer, 0.21 x 0.71, 0.06 thick
62	131258400	Screw, 10-16AB x 0.500
68	131707800	Ring, drain hose
68*	5303309503	Clip, drain hose, back sheet
69	131731500	Fastener, ratchet

TRANSMISSION

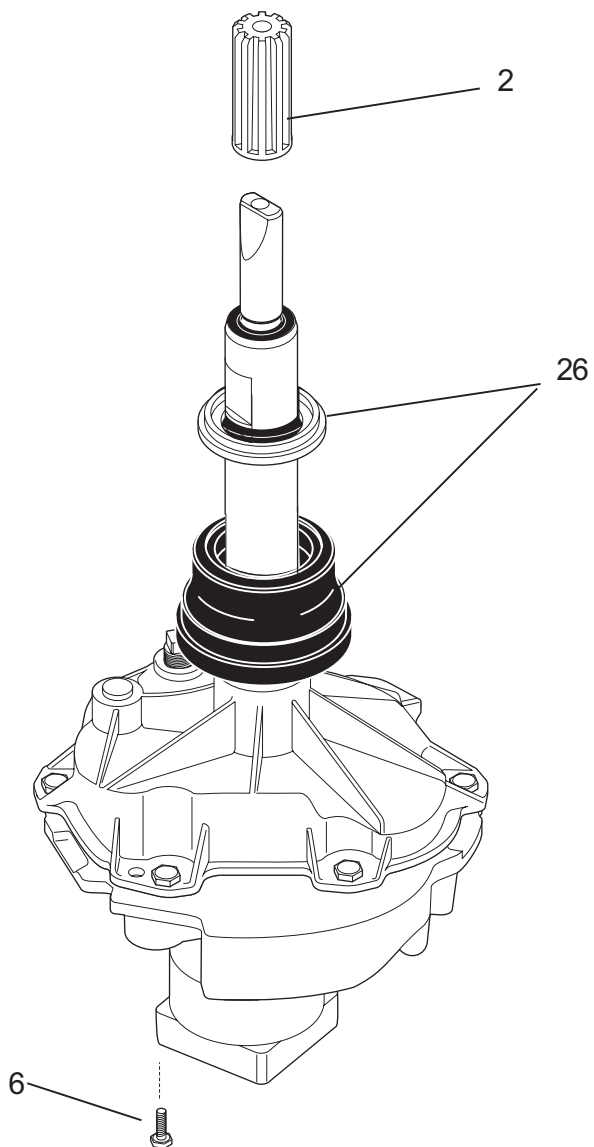
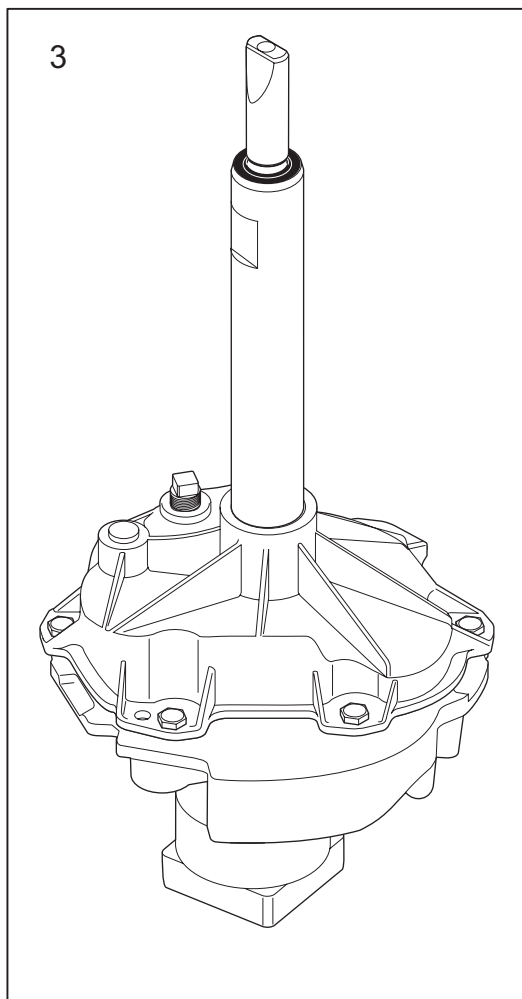

P17M0015

TRANSMISSION

POS. NO	PART NO.	DESCRIPTION
2 #	131475100	Hub, drive, agitator
3	131878401	Transmission Assy, H+-helical gear
6	134197900	Screw, hex washer head, 1/4-20 x 0.437
26 #	5303279394	Seal Assy, tub, transmission

WIRING DIAGRAM

CAUTION: DISCONNECT ELECTRIC CURRENT BEFORE SERVICING. LABEL ALL WIRES PRIOR TO DISCONNECTION WHEN SERVICING CONTROLS. WIRING ERRORS CAN CAUSE IMPROPER AND DANGEROUS OPERATION. VERIFY PROPER OPERATION AFTER SERVICING.

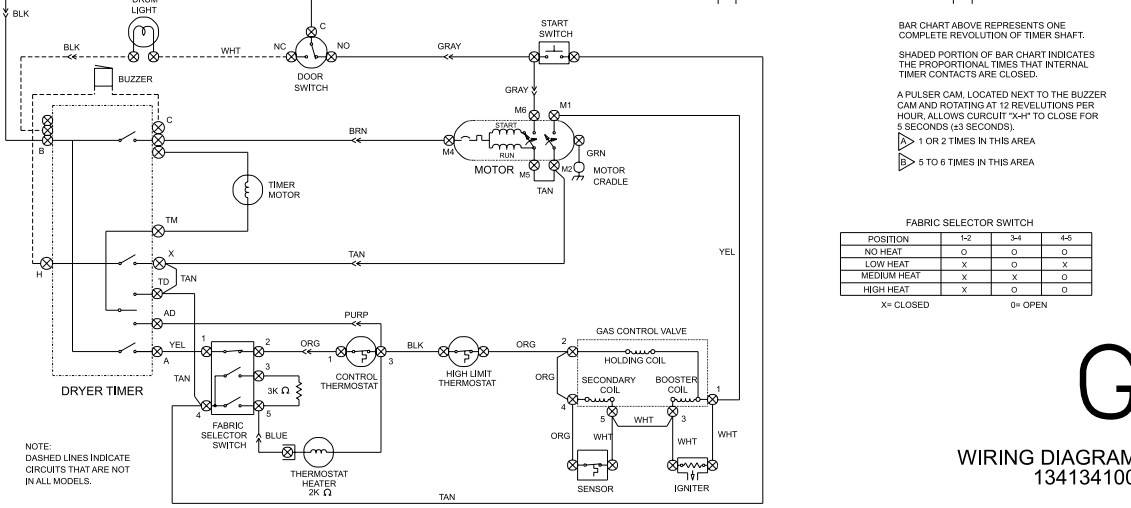
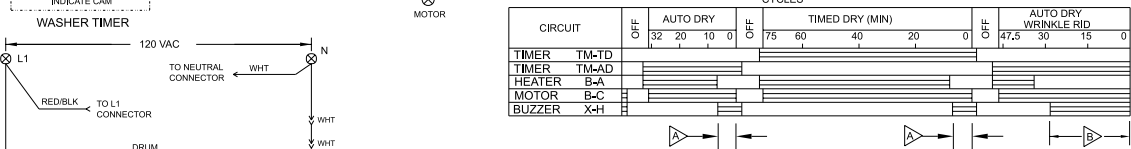
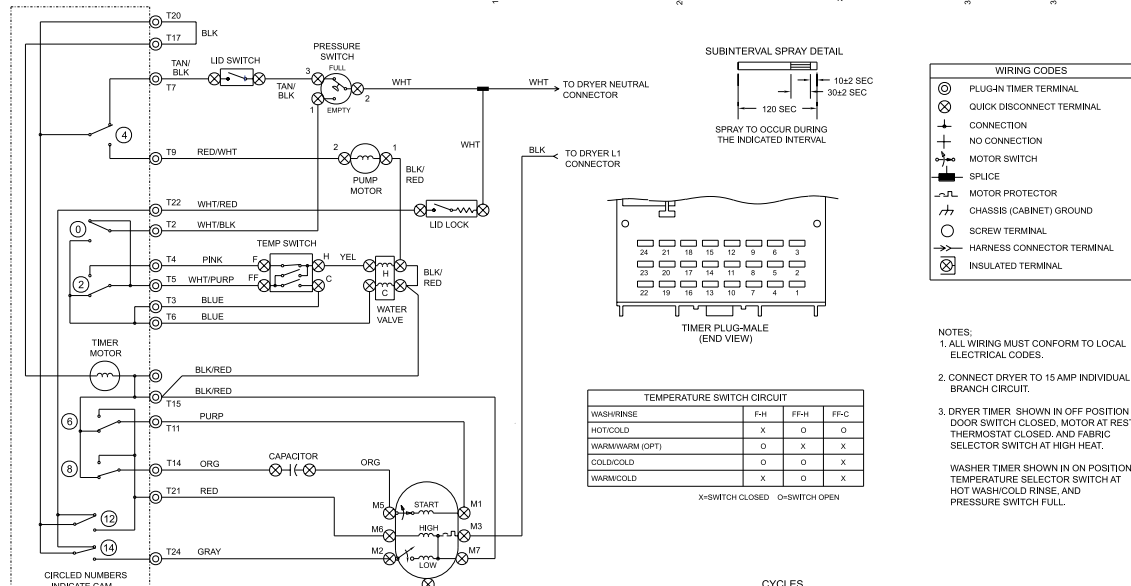
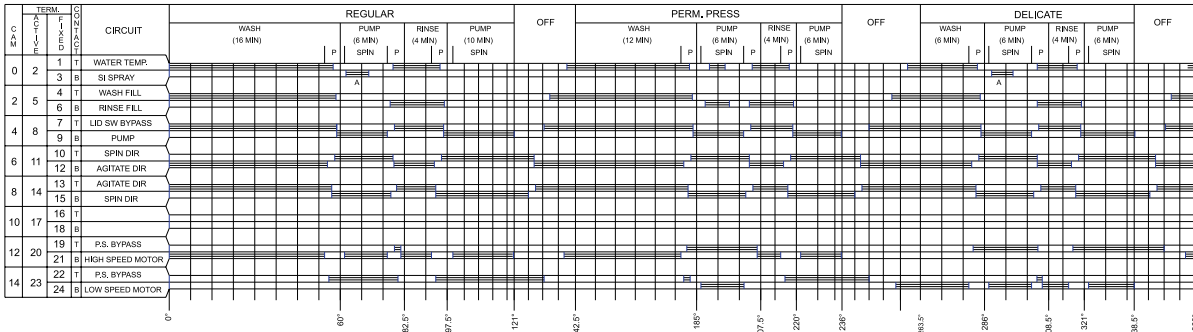

WIRING DIAGRAM
134134100