

Viking Use/Installation Guide



Viking Range Corporation
111 Front Street
Greenwood, Mississippi 38930 USA
(662) 455-1200

For more product information,
call 1-888-VIKING1 (845-4641)
or visit the Viking Web site at
vikingrange.com

Charcoal Ceramic Cooking Capsule™

Congratulations. . .

Your purchase of this product attests to the importance you place upon the quality and performance of the major appliances you use. With minimal care, as outlined in this guide, this product is designed to provide you with years of dependable service. Please take the few minutes necessary to learn the proper and efficient use and care of this quality product.

We appreciate your choosing a Viking Range Corporation product, and hope that you will again select our products for your other major appliance needs.

Table of Contents

Unpacking	2
Parts Included With Your Cooker	3
Before Installing Your C4 Outdoor Cooker	4
Lighting Your Cooker	6
Approximate Damper Adjustments	7
Cleaning and Maintenance	9
Service Information	10
Warranty	Rear cover

Unpacking

1. Remove cooker from box.
2. Remove all parts within the cooker in order to remove any styrofoam or cardboard packaging. (See Figure 1)
3. After removing all packaging materials, replace parts inside unit as shown on the next page, beginning at the bottom and going up.

NOTE: Upon first opening and examining your cooker, some hairline cracks and powder residue may be found in the ceramic fire box. These are common and normal characteristics of a ceramic product.

Parts Included With Your Cooker

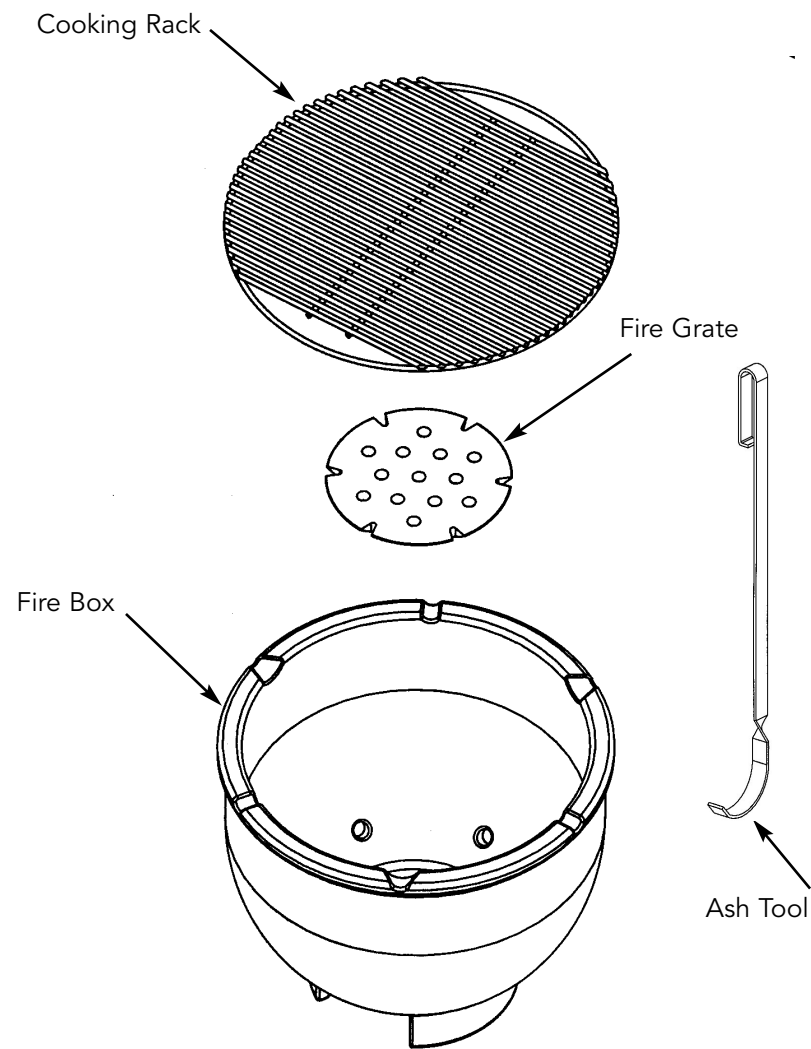

Figure 1

Before Installing Your C4 Outdoor Cooker

After unpacking the cooker, the dome will need to be removed before installing on a cart.

CAUTION

Keep hands and fingers out of spring area.

To remove the dome:

Install shipping screws into each side of hinge. (See figure 2). Remove the two (2) top nuts and washers on each side of the hinge mount.

Remove dome and set aside.

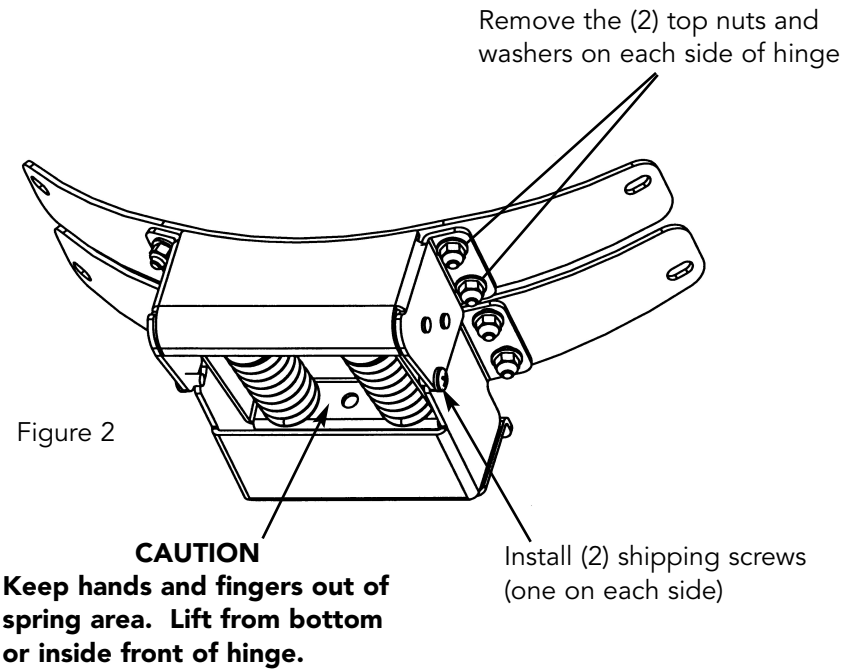

To replace the dome:









Place dome on the cooker. Re-install the two (2) top nuts and washers on each side of the hinge mount. Remove the shipping screws from each side of the hinge. Replace inside parts.

Lighting Your Cooker

1. Open the dome until it locks it in place and remove the cooking rack.
2. Crumple 1-2 double-wide newspaper sheets and place them on the ceramic fire grate. Place 2-3 hand fulls of natural lump charcoal (not briquettes) on top of the newspaper. Lump charcoal lights easily with a little newspaper and does not contain fillers or additives and gives the food a natural charbroiled taste. After cooking, the remaining charcoal can be extinguished by closing the dampers and reused again.
3. Open the bottom draft door COMPLETELY. Light the newspaper in several places. After newspaper starts to burn, close the dome by pulling on the dome handle. Open the slide metal top COMPLETELY. The air flow will help light the charcoal. If preferred, you can use an electric starter, or charcoal starter. **DO NOT** use lighter fluid.
4. Check the thermometer often during the heat-up of the cooker. (Dampers open during heat-up). When the temperature approaches the desired setting, adjust the top and bottom dampers to set the temperature. Start with the dampers open 1/4" to 1/2" and adjust as required. To lower the temperature, close dampers. To raise the temperature, open the dampers. Readjust dampers to maintain desired temperature.
5. When the temperature is set, put your food on. After a few times using the cooker, you will be able to control the temperature easily. When you finish cooking, completely close the bottom draft door and the slide metal top. This will extinguish the remaining charcoals and allow you to use it again.
6. Since your cooker uses ceramic materials, it holds the heat better and longer. Due to this, if the cooker gets too hot it may take longer to lower the temperature. Therefore, when cooking it is very important to constantly adjust the dampers to control the air flow. If you continue to have problems with the cooker becoming too hot, you may want to reduce the amount of charcoal being used.

7. For the best cooking results, use a meat thermometer when cooking large pieces of meat such as beef, ham, turkey, whole chickens, etc. The use of a meat thermometer will allow you to determine if the meat is cooked properly and safely.

Approximate Damper Adjustments

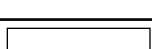
Temperature		Top Damper	Bottom Damper
150°	Smoking jerky/fish		
300°	Chicken pieces, grilling hamburger and ribs		
325°	Poultry, turkey breast		
350°	Roasting beef, pork and lamb		
450° or higher	Searing steaks		

 Amount closed  Amount opened

Suggested Cooking Times at 325° - 350°F*

- Chicken (whole)60-80 min.
- Chicken (pieces)30-45 min.
- Ham2 - 5 hrs.
- Turkey (whole stuffed, 18 lbs.)3-4 hrs.
- Turkey (whole unstuffed, 12 lbs.)2-3 hrs.
- Turkey Breast (8 lbs.)2-3 hrs.
- Leg of Lamb3-4 hrs.
- Beef Roast (8-15 lbs.)2-3 hrs.
- Boston Butt (Bone-In, 8 lbs.)3-4 hrs.

***NOTE:** The above information is given only as a guide. For more accurate cooking times, use a meat thermometer.

Meat Thermometer Internal Temperatures

Food	Rare	Medium	Well Done
Beef	140°F	160°F	180°F
Poultry	Not Rec.	170°F	180°F
Lamb	140°F	160°F	180°F
Pork	Not Rec.	160°F	175°F
Fish	Not Rec.	Not Rec.	when soft & flaky

Lighting the Side Burners (If applicable):

First remove the burner cover or any cooking utensil from the burner grate.

⚠ CAUTION: The side burner cover may be hot if the cooker is in operation. Push and turn the control knob until the High position aligns with the indicator line on the control panel. **Immediately press the electronic ignition button corresponding to the burners being lit until the burner is lit or until 4 seconds pass. If the burner does not light after several attempts, wait 5 minutes to allow any accumulated gas to dissipate.** If the burner will not light after several attempts, then the burner can be match lit by holding a lit match next to the burner ports.

Cleaning and Maintenance

After use, clean up the ashes which have fallen through the fire grate into the bottom. They can be removed through the bottom draft door with the ash tool. Do not let the ash build up, this will hinder the air flow through the bottom draft door.

Your cooker can be placed anywhere outside your home. The cooker can be used year round. Cold weather or rain will not affect the quality of cooking.

Drip Tray (if applicable)

The drip tray pan should be removed and cleaned after each use. Allow the drippings in the drip tray pan to cool completely before removing. Place the pan in hot, soapy water to clean. Wipe up any debris that may have collected in the drip tray with a hot, soapy towel. Dry and replace drip tray pan before next use.

Battery Replacement (if applicable)

The side burner is equipped with a battery for the electronic ignition. It is located to the right of the side burner knobs under the control panel. The battery location is shown on the control panel.

To replace the battery:

1. Slide out the drip tray.
2. Locate the round black cap which is inside the burner box under the battery symbol on the control panel.
3. Unscrew cap. Battery is snapped in the cap.
4. Replace the battery by connecting corresponding post to post inside burner box.
5. Snap cap on battery and screw back into slot underneath control panel.

Service Information

If service is required:

1. Call your dealer or authorized service agency. The name of the authorized service agency can be obtained from the dealer or distributor in your area.
2. Have the following information readily available:
 - a. Model number
 - b. Date purchased
 - c. Name of dealer from whom purchased
3. Clearly describe the problem that you are having.

If you are unable to obtain the name of an authorized service agency or if you continue to have service problems, contact Viking Range Corporation at (888) 845-4641 or write to:

VIKING RANGE CORPORATION
PREFERRED SERVICE
111 Front Street
Greenwood, Mississippi 38930 USA

Record the information indicated below. You will need it if service is ever required.

Model Number - _____

Date of Purchase _____ Date Installed _____

Dealer's Name _____

Address _____

If service requires installation of parts, use only authorized parts to ensure protection under the warranty.

KEEP THIS MANUAL FOR FUTURE REFERENCE

**PROFESSIONAL SERIES
CHARCOAL CERAMIC COOKING CAPSULE™
ONE YEAR FULL WARRANTY**

C4™ outdoor cookers and all of their components and accessories, except as detailed below*, are warranted to be free from defective materials or workmanship in normal use for a period of twelve (12) months from the date of original purchase. Viking Range Corporation, warrantor, agrees to repair or replace, at its option, any part which fails or is found to be defective during the warranty period.

*Painted, porcelain, and decorative items are warranted to be free from defective materials or workmanship for a period of ninety (90) days from the date of original retail purchase. ANY DEFECTS MUST BE REPORTED TO THE SELLING DEALER WITHIN NINETY (90) DAYS FROM DATE OF ORIGINAL RETAIL PURCHASE.

Viking Range Corporation uses the most up-to-date processes and best materials available to produce all color finishes. However, slight color variation may be noticed because of the inherent differences in painted parts and porcelain parts as well as differences in kitchen lighting, product locations, and other factors.

LIFETIME LIMITED WARRANTY

All ceramic parts and any stainless steel part which **rusts through** due to defective material or workmanship in normal use during the second year through the useful lifetime of the cooker from date of original retail purchase will be repaired or replaced, free of charge for the part itself, with the owner paying all other costs, including labor.

This warranty extends to the original purchaser of the product warranted hereunder and to each transferee owner of the product during the term of warranty.

This warranty shall apply to products purchased and located in the United States and Canada. Products must be purchased in the country where service is requested. Warranty labor shall be performed by an authorized Viking Range Corporation service agency or representative. Warranty shall not apply to damage resulting from abuse, accident, natural disaster, alteration, improper installation, improper operation or repair or service of the product by anyone other than an authorized Viking Range Corporation service agency or representative. This warranty does not apply to commercial usage. Warrantor is not responsible for consequential or incidental damage whether arising out of breach of warranty, breach of contract, or otherwise. Some jurisdictions do not allow the exclusion or limitation of incidental or consequential damages so the above limitation or exclusion may not apply to you.

Owner shall be responsible for proper installation, providing normal care and maintenance, providing proof of purchase upon request, and making the appliance reasonably accessible for service. If the product or one of its component parts contains a defect or malfunction during the warranty period, after a reasonable number of attempts by the warrantor to remedy the defects or malfunctions, the owner is entitled to either a refund or replacement of the product or its component part or parts. Warrantor's liability on any claim of any kind, with respect to the goods or services covered hereunder, shall in no case exceed the price of the goods or services or part thereof which gives rise to the claim.

Warranty service under the terms of this warranty, service must be performed by a factory authorized Viking Range Corporation service agent or representative. Service will be provided during normal business hours and labor performed at overtime or premium rates shall not be covered by warranty. To obtain warranty service, contact the dealer from whom the product was purchased, an authorized Viking Range Corporation service agent, or Viking Range Corporation. For the name of your nearest authorized Viking Range Corporation service agency, call the dealer from whom the product was purchased. If you do not receive a satisfactory response, please call Viking Range Corporation Customer Service (662)451-4133. **IMPORTANT:** Retain proof of original purchase to establish warranty period.

The return of the Owner Registration Card is not a condition of warranty coverage. You, however, should return the Owner Registration Card so that Viking Range Corporation can contact you should any questions of safety arise which could affect you.

Any implied warranties of merchantability and fitness applicable to the above described porcelain cooker grates, ceramic parts, and stainless steel parts are limited in duration to the period of coverage of the applicable express written limited warranties set forth above. Some jurisdictions do not allow limitations on how long an implied warranty lasts, so the above limitation may not apply to you. This warranty gives you specific legal rights, and you may also have other rights which may vary from jurisdiction to jurisdiction.

Specifications subject to change without notice.