

# Installation Instructions

## for Frontload Washers

### Inside.....

Washer Dimensions.....	2
Before You Start.....	2
Installation.....	3
Installer Checklist.....	Back Cover

Para bajar una copia de estas instrucciones en español, visite [www.speedqueen.com](http://www.speedqueen.com).

Keep these instructions for future reference.

(If this machine changes ownership, this manual must accompany machine.)

Date Purchased \_\_\_\_\_

Model Number \_\_\_\_\_

Serial Number \_\_\_\_\_

## Washer Dimensions

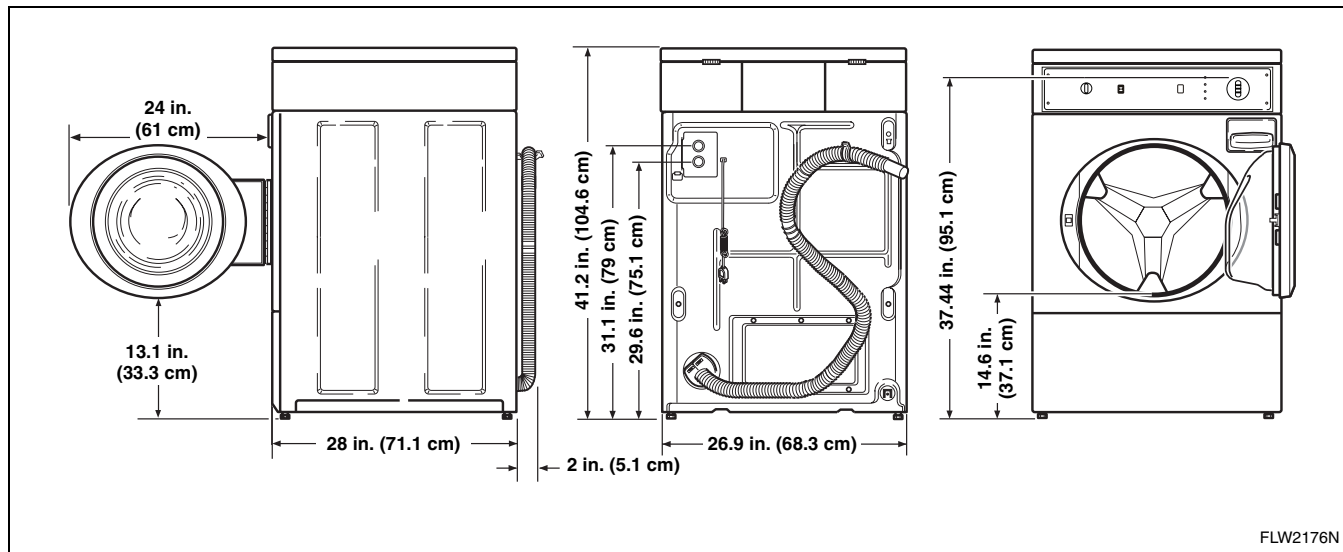

Figure 1

## Before You Start

### Supplies

For most installations, the basic supplies you will need are:

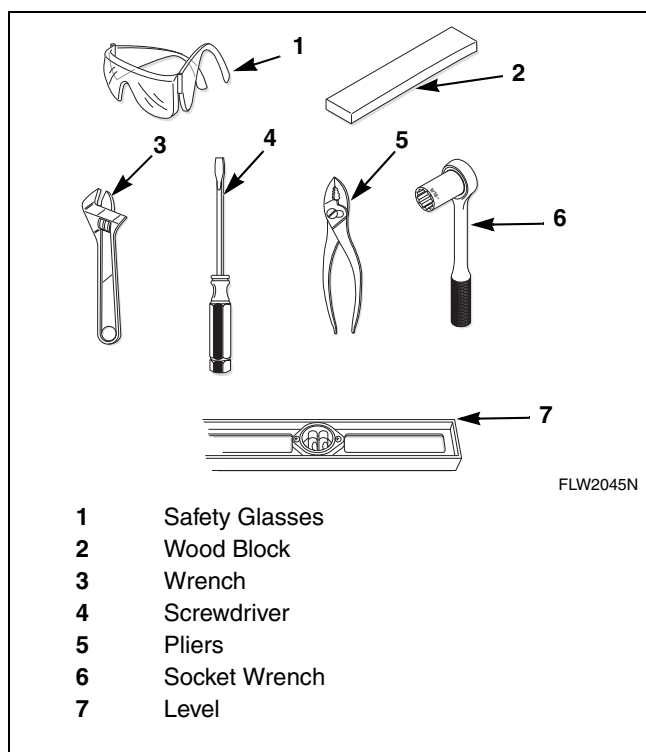

Figure 2

### Parts Included

An accessories bag has been shipped inside your washer. It includes:

- Two fill hoses with washers and filter screens. Refer to step 2 of *Installation*.
- Four rubber feet. Refer to step 4 of *Installation*.
- Beaded strap. Refer to step 3 of *Installation*.
- Installation Instructions.
- User's Guide.
- Product Registration Card.
- Warranty Bond.

**NOTE:** If the washer is delivered on a cold day (below freezing), or is stored in an unheated room or area during the cold months, do not attempt to operate it until the washer has had a chance to warm up.

**NOTE:** Some moisture in the wash drum is normal. Water is used during testing at the manufacturer.

**NOTE:** Install dryer before washer. This allows room for attaching exhaust duct.

## Installation

### Step 1: Position Washer Near Installation Area

Move washer as close to the desired area of installation as possible.

**NOTE: For best performance and to minimize vibration or movement, install washer on a solid, sturdy and level floor. Some floors may need to be reinforced, especially on a second floor or over a basement. Do not install the washer on carpeting, soft tile, a platform or other weakly supported structures.**

### Step 2: Connect Fill Hoses

	<b>WARNING</b>
<p><b>Under certain conditions, hydrogen gas may be produced in a hot water system that has not been used for two weeks or more. HYDROGEN GAS IS EXPLOSIVE. If the hot water system has not been used for such a period and before using the washer, turn on all hot water faucets and let the water flow from each for several minutes. This will release any accumulated hydrogen gas. The gas is flammable. Do not smoke or use an open flame during this time.</b></p>	
<small>W029</small>	

#### Water Supply

Water supply faucets must fit standard 3/4 inch (19.1 mm) female garden hose couplings. **DO NOT USE SLIP-ON OR CLAMP-ON CONNECTIONS.**

Water supply faucets should be readily accessible to permit turning them off when washer is not being used.

Recommended cold water temperature is 60° to 80° Fahrenheit (16° to 27° Celsius). Recommended hot water temperature is 120° to 140° Fahrenheit (49° to 60° Celsius). Warm water is a mixture of hot and cold water. Warm water temperature is dependent upon water temperature and pressure of both the hot and cold water supply lines.

Water pressure must be a minimum of 20 to a maximum of 120 pounds per square inch (138 to 827 kPa) static pressure measured at the faucet.

**NOTE: Water pressure under 20 pounds per square inch (138 kPa) will cause an extended fill time in the washer and may not properly flush out the detergent dispenser.**

Turn on the water faucets and flush the lines for approximately two minutes to remove any foreign material that could clog the screens in the water mixing valve.

**NOTE: When installing in newly constructed or renovated buildings, it is very important to flush the lines since build-up may have occurred during construction.**

#### Connecting Hoses

Remove the two plain rubber washers and two filter screens from the accessories bag. Install them into each end of the fill hoses as shown in *Figure 3*. The screen must be facing outward.

Screw hose couplings with the filter screens onto the water faucets until they are finger-tight. Then, using a pliers, screw approximately 1/4 turn. Use the red color-coded hose for the hot water connection and the blue color-coded hose for the cold water connection.

Screw hose couplings from other end of hoses onto the water mixing valve until they are finger-tight. Then, using a pliers, screw approximately 1/4 turn. Refer to *Figure 4*. Make sure the red color-coded hose from the hot water faucet goes to the water mixing valve marked “H” and the blue color-coded hose from the cold faucet goes to the valve marked “C”.

**IMPORTANT: Do not cross thread or overtighten couplings. This will cause them to leak.**

Turn water on and check for leaks. If leaks are found, turn off the water, unscrew hoses and reinstall them until there are no leaks.

**IMPORTANT: Turn off water supply whenever there will be an extended period of non-use.**

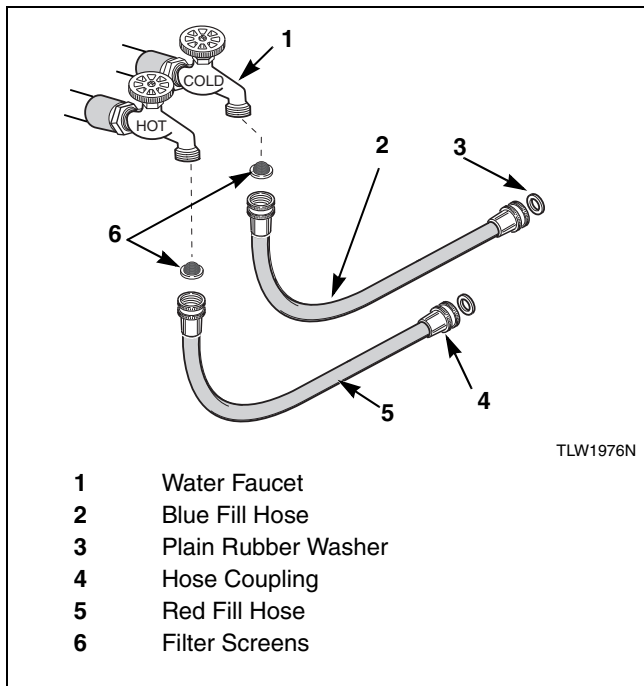

Figure 3

**IMPORTANT:** Hoses and other natural rubber parts deteriorate after extended use. Hoses may develop cracks, blisters or material wear from the temperature and constant high pressure they are subject to.

All hoses should be checked on a yearly basis for any visible signs of deterioration. Any hose showing the signs of deterioration listed above should be replaced immediately. All hoses should be replaced every five years.

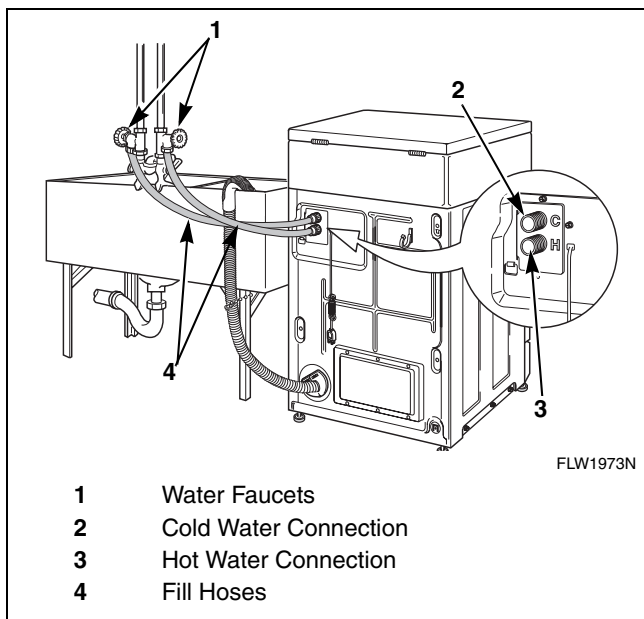

Figure 4

### Step 3: Connect Drain Hose to Drain Receptacle

Remove the drain hose from its shipping position on the rear of the washer by unhooking the hose from the retainer clamp and by removing the shipping tape.

Install the drain hose into the drain receptacle (standpipe, wall or laundry tub) following the instructions below.

**IMPORTANT:** Drain receptacle must be capable of handling a minimum of 1-1/4 inch (3.2 cm) outside diameter drain hose.

#### Standpipe Installation:

Place the drain hose into the standpipe.

Remove the beaded strap from accessories bag and place around standpipe and drain hose and tighten strap to hold hose to standpipe. Refer to *Figure 5*. This will prevent the drain hose from dislodging from drain receptacle during use.

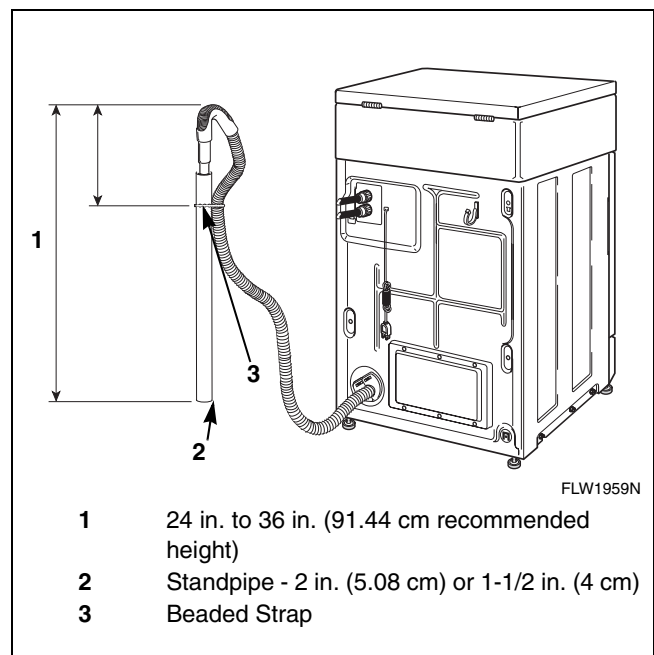

Figure 5

#### Wall Installation:

For installations of this type, the drain hose **MUST** be secured to one of the fill hoses using the beaded strap from accessories bag. Refer to *Figure 6*.

**NOTE:** End of drain hose must be below 24 in. (61 cm).

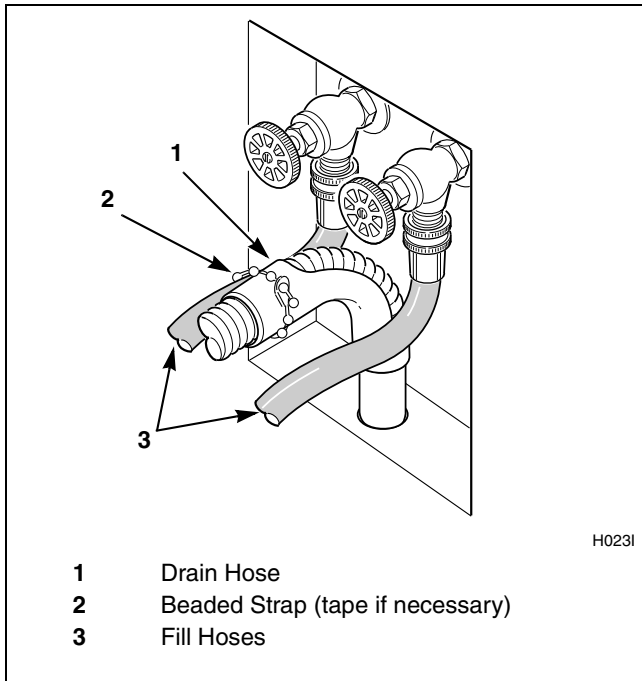

Figure 6

**Laundry Tub Installation:**

For this type of installation, the drain hose MUST be secured to the stationary tub to prevent hose from dislodging during use. Refer to Figure 7. Use the beaded strap (supplied in accessories bag) to secure hose.

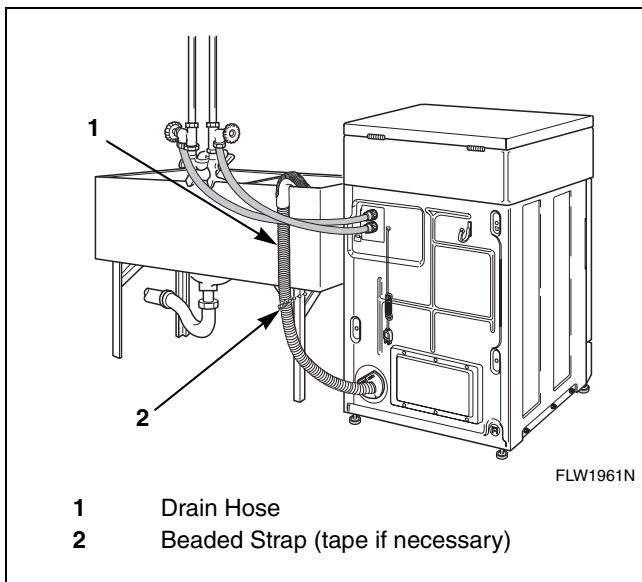

Figure 7

**Step 4: Position and Level the Washer**

Position washer so it has sufficient clearance for installation and servicing.

**NOTE: Use of the dispenser drawer or washer door as a handle in the transportation of the washer may cause damage to the dispenser or door.**

Place washer in position on a solid, sturdy and level floor. Installing the washer on any type of carpeting, soft tile, a platform or other weakly supported structures is not recommended.

For easier access to leveling legs, prop up washer with a wooden block. Refer to Figure 8.

Place a level on the cabinet top and check if the washer is level from side to side and front to back.

**NOTE: Level must rest on raised portion of top panel. Refer to Figure 8.**

If washer is not level, tilt washer to access the front and rear leveling legs. Loosen the locknuts and adjust legs by screwing into or out of washer base.

Make sure that the washer does not rock. When washer is level and does not rock, tighten locknuts securely against bottom of washer base. If these locknuts are not tight, washer will move out of position during operation.

Do not slide washer across floor once the leveling legs have been extended. Legs and base could become damaged.

Place rubber feet (supplied in accessories bag) on all four leveling legs. Refer to Figure 8.

Verify that washer does not rock.

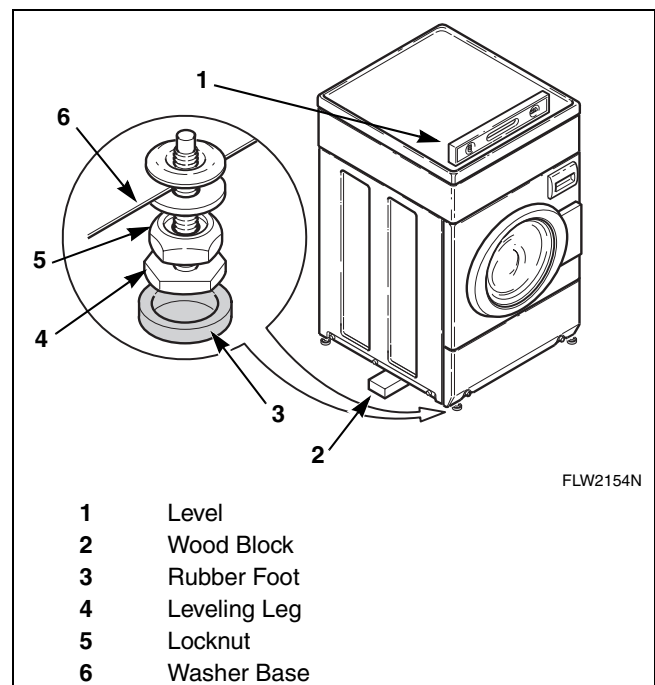

Figure 8

## Step 5: Remove the Shock Sleeves and Shipping Brace

Remove front access panel by removing the two screws at the bottom of the panel.

Remove the five bolts and lockwashers from shipping brace with 9/16 inch wrench and remove brace. Refer to *Figure 9*. Four bolts are located on the washer base and one is holding the brace to the weight. Remove shock sleeves by pulling on the yellow rope. Refer to *Figure 9*.

Make sure all four shock sleeves are removed. Remove label from front side of front access panel and place on backside of front access panel for future reference.

Store the shipping materials in the accessories bag. Save materials for use whenever the unit is moved.

Reinstall front access panel.

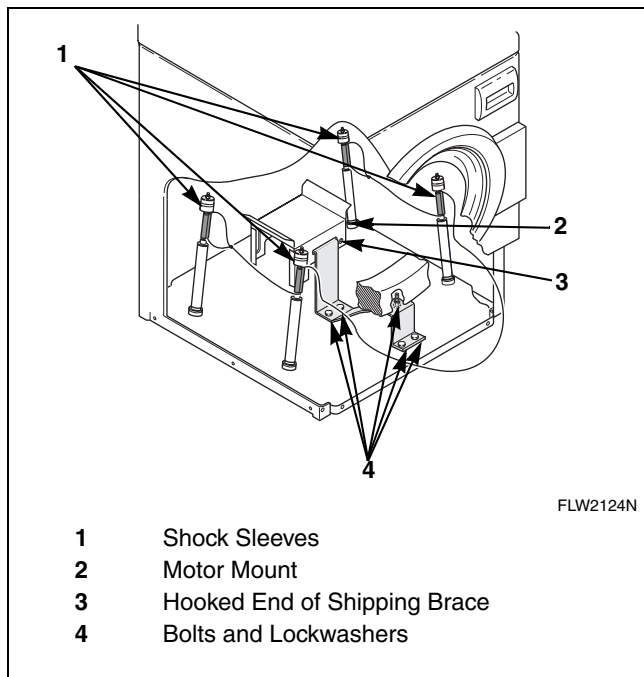

Figure 9

**IMPORTANT:** The shipping brace, bolts, lockwashers and shock sleeves should be saved and **MUST** be reinstalled whenever the unit is moved more than four feet. Do not lift or transport unit from front or without shipping materials installed. Refer to the User's Guide for proper instructions on reinstalling the shipping materials.

**IMPORTANT:** DO NOT tip washer more than 6 inches (152.4 mm) in any direction after shipping brace has been removed. Shock absorbers may separate and damage to washer may result. For leveling purposes, the washer may be tilted a maximum of 6 inches (152.4 mm) in any direction.

## Step 6: Wipe Out Inside of Washer Drum

Before using the washer for the first time, use an all-purpose cleaner, or a detergent and water solution, and a damp cloth to remove shipping dust from inside the drum.

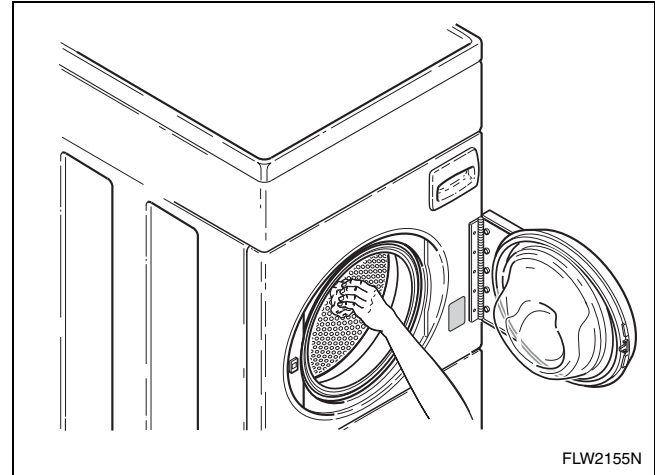

Figure 10

## Step 7: Plug in the Washer

Washer requires 120 Volt, 60 Hertz electrical supply and comes equipped with a 3-prong grounding plug. Refer to serial plate for specific electrical requirements.

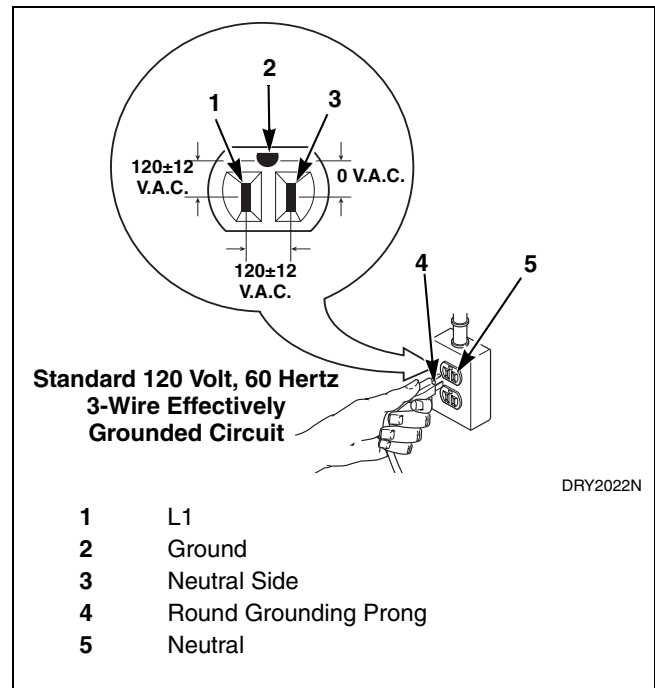



Figure 11

	<b>WARNING</b>
<p><b>To reduce the risk of fire, electric shock or personal injury, all wiring and grounding MUST conform with the latest edition of the National Electrical Code, ANSI/NFPA 70, and such local regulations as might apply. It is the customer's responsibility to have the wiring, fuses and circuit breakers installed by a qualified electrician to make sure adequate electrical power is available to the washer.</b></p>	
W518	

When plugging in the washer:

- DO NOT overload circuits.
- DO NOT use an extension cord.
- DO NOT use an adapter.
- DO NOT operate both a washer and gas dryer on the same circuit. Use separately fused 15 Amp circuits.

The washer is designed to be operated on a separate branch, polarized, three-wire, effectively grounded, 120 Volt, 60 Hertz, AC (alternating current) circuit protected by a **15 Amp fuse**, equivalent fusetrone or circuit breaker.

The three-prong grounding plug on the power cord should be plugged directly into a polarized three-slot effectively grounded receptacle rated 110/120 Volts AC (alternating current) 15 Amps. Refer to *Figure 11* to determine correct polarity of the wall receptacle.

	<b>WARNING</b>
<p><b>To reduce the risk of an electric shock or fire, DO NOT use an extension cord or an adapter to connect the washer to the electric power source.</b></p>	
W082	

### Grounding Information

The washer must be grounded. In the event of malfunction or breakdown, grounding will reduce the risk of electric shock by providing a path of least resistance for electric current.

The washer is equipped with a cord having an equipment-grounding conductor and a 3-prong grounding plug. The plug must be plugged into an appropriate outlet that is properly installed and grounded in accordance with all local codes and ordinances.

	<b>WARNING</b>
<p><b>Improper connection of the equipment-grounding conductor can result in a risk of electric shock. Check with a qualified electrician or service person if you are in doubt as to whether the washer is properly grounded.</b></p>	
W216	

Do not modify the plug provided with the washer - if it will not fit the outlet, have a proper outlet installed by a qualified electrician.

**NOTE: Have a qualified electrician check the polarity of the wall receptacle. If a voltage reading is measured other than that in *Figure 11*, the qualified electrician should correct the problem.**

	<b>WARNING</b>
<p><b>This unit is equipped with a three-prong (grounding) plug for your protection against shock hazard and should be plugged directly into a properly grounded three-prong receptacle. Do not cut or remove the grounding prong from this plug.</b></p>	
W213	

**NOTE: The wiring diagram is located behind the control panel, inside the control cabinet.**

### Step 8: Check Installation

Refer to *Installer Checklist* on the back cover of this manual and make sure that washer is installed correctly.

Run washer through one complete cycle to make sure it is operating properly.

# Installer Checklist

## Fast Track for Installing the Washer

(Refer to the manual for more detailed information)

- 1** • Position Washer Near Installation Area.

CHECK

- 5** • Remove the Shock Sleeves and Shipping Brace.

CHECK

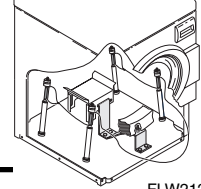

FLW2124N

- 2** • Connect Fill Hoses.

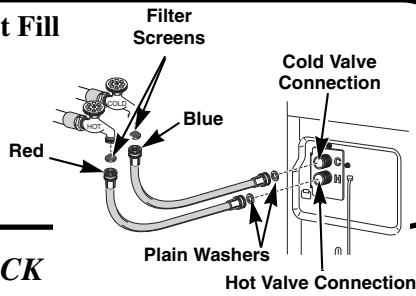

CHECK

FLW2054N

- 6** • Wipe Out Inside of Washer Drum

CHECK

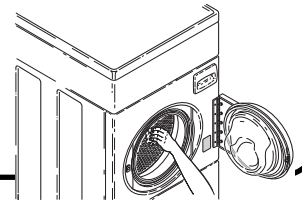

FLW2155N

- 3** • Connect Drain Hose to Drain Receptacle.

CHECK

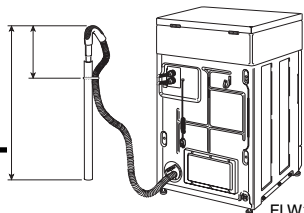

FLW1959N

- 7** • Plug in the Washer.

CHECK

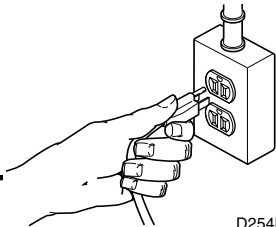

D254I

- 4** • Position and Level the Washer.

CHECK

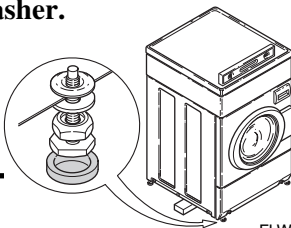

FLW2154N