

Frigidaire

Factory Parts Catalog

Product No.	FSC23F7DB4	FSC23F7DW4	FSC23F7DSB6
Series	counter depth	counter depth	counter depth
Color	black	white	stainless
Volts	115	115	115
Wiring Diagram	241516401A	241516401A	241516401A
Owner's Guide	241694600	241694600	241694600
Market	North America	North America	North America
Energy Guide	240598639	240598639	241585916
Service Data Sheet	241532603	241532603	241532603

 **Electrolux**

Electrolux Major Appliances
North & Latin America
P.O. BOX 212378
AUGUSTA, GA 30917

Publication No.
5995457842
06/01/09
(EN/SERVICE/KHB)
137

**SIDE-BY-SIDE
REFRIGERATOR**

Model No.
FSC23F7D

Copyright © 2006 Electrolux Home Products, Inc.
All rights reserved.

FREEZER DOOR

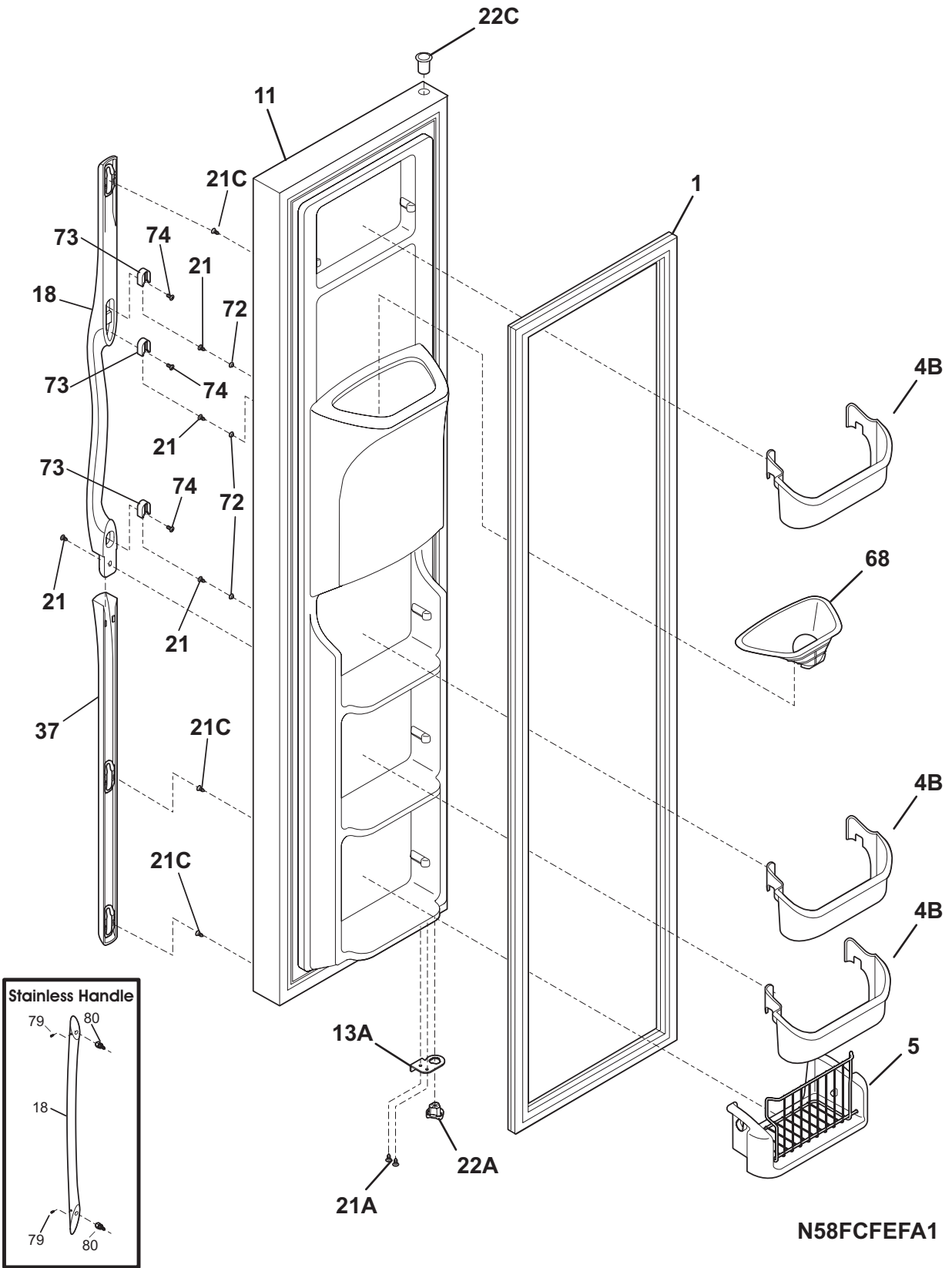

FREEZER DOOR

Model Index: A FSC23F7D (FSC23F7DB4)
 B FSC23F7D (FSC23F7DW4)
 C FSC23F7DS (FSC23F7DSB6)

POS. NO	PART NO.		DESCRIPTION
1 #	241510204	A - C	Gasket-frzr door, black, magnetic
1 #	241510202	- B -	Gasket-frzr door, white, magnetic
4B	241511602	A B C	Bin-door
5	241545001	A B C	Bin-tilt out, tilt-out
11	241668172	A - -	Door-frzr, black, complete assy
11	241668123	- B -	Door-frzr, white, complete assy
11	241668503	- - C	Door-frzr, stainless, complete assy
13A	240581906	A - C	Door Stop, black, frzr
13A	240581902	- B -	Door Stop, white, frzr
18	240359108	A - -	Handle-door, black, LH
18	240359106	- B -	Handle-door, white
18	240536801	- - C	Handle-door, stainless steel, with insert
21	218781100	A B C	Screw, pan head, 8-18 x 0.625
21C	240521302	A B -	Screw, #8-18 x 3/4
21A	240598401	A B C	Screw, 10-32 x 1/2
22A	240328204	A - C	Bearing-hinge(frz), black, closer
22A	240328202	- B -	Bearing-hinge(frz), closer
22C	240328404	A - C	Bearing-hinge, black, upper
22C	240328402	- B -	Bearing-hinge, natural, upper
37	240359203	A - -	Trim-handle, 30.13", black, lower
37	240359201	- B -	Trim-handle, 30.13", white, lower
68	241525101	A B C	Chute-ice
72	240421701	A B -	Button-handle mtg, dovetail
73	218396700	A B -	Block-handle mtg, dovetail
74	215503200	A B C	Screw, cr pan hd, 10-16 x 0.500
79	218755402	- - C	Screw-set, 10-32 x 0.375
80	218755503	- - C	Screw-shoulder, #10 AB, handle mounting
*	240352102	A B C	Connector-water, straight
*	240552102	A B C	Harness-wiring, door
*	5303918256	A B C	Dispenser heater kit

REFRIGERATOR DOOR

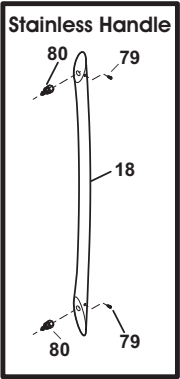
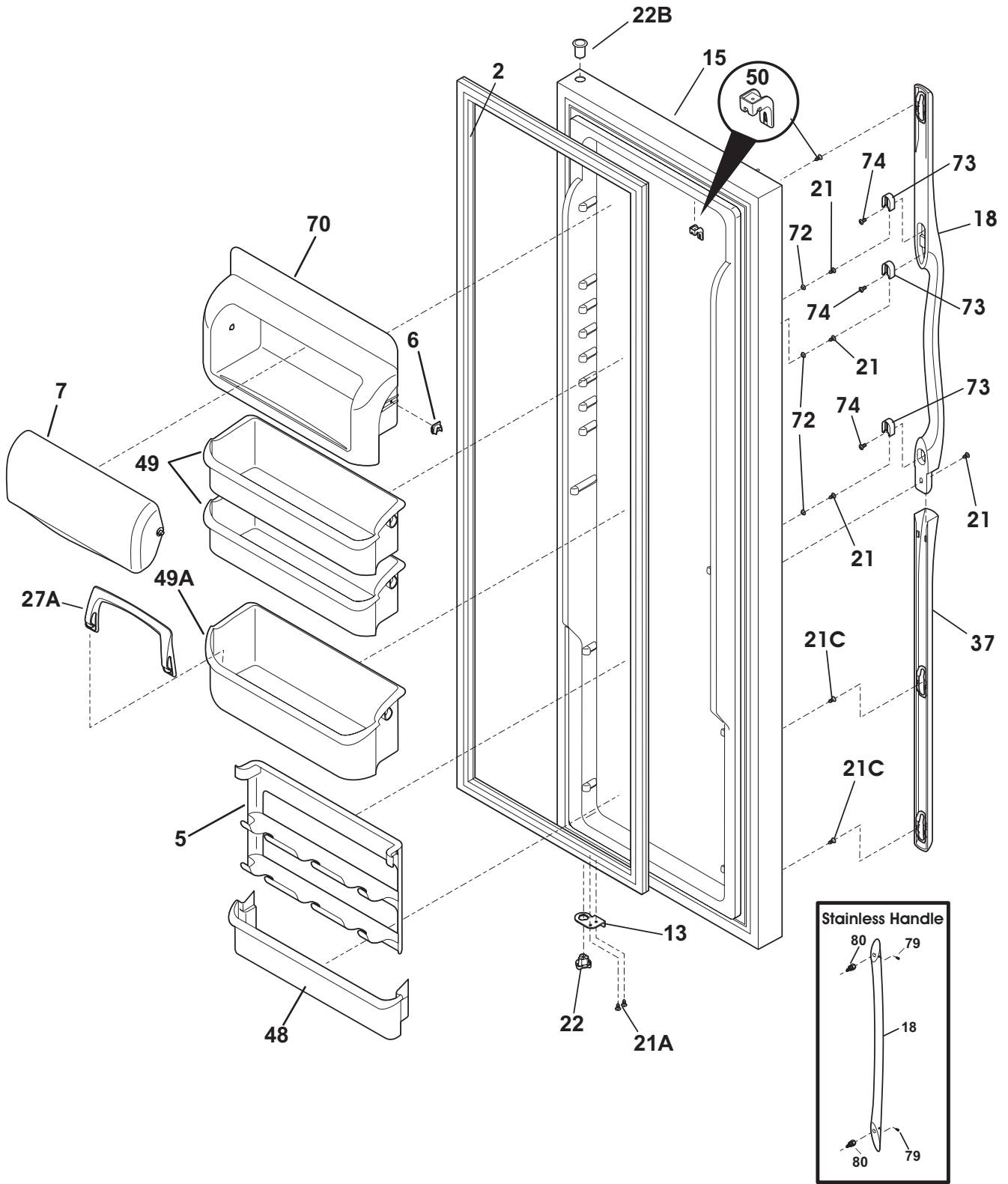

N58RCFCHA6

REFRIGERATOR DOOR

Model Index: A FSC23F7D (FSC23F7DB4)
 B FSC23F7D (FSC23F7DW4)
 C FSC23F7DS (FSC23F7DSB6)

POS. NO	PART NO.		DESCRIPTION
2 #	241510203	A - C	Gasket-refr door, black, magnetic
2 #	241510201	- B -	Gasket-refr door, white, magnetic
5	241516102	A B C	Rack-can
6	241515901	A B C	Lug-dairy compartment
7	241515601	A B C	Door-dairy
13	240581905	A - C	Door Stop, black, ref
13	240581901	- B -	Door Stop, white, refr
15	241534505	A - -	Door-refr, black, complete assy
15	241534504	- B -	Door-refr, white, complete assy
15	241534533	- - C	Door-refr, stainless, complete assy
18	240359103	A - -	Handle-door, black, RH
18	240359101	- B -	Handle-door, white
18	240536801	- - C	Handle-door, stainless steel, with insert
21	218781100	A B C	Screw, pan head, 8-18 x 0.625
21A	240598401	A B C	Screw, 10-32 x 1/2
21C	240521302	A B -	Screw, #8-18 x 3/4
22	240328203	A - C	Bearing-hinge, black, closer
22	240328201	- B -	Bearing-hinge(ref), closer
22B	240328404	A - C	Bearing-hinge, black, upper
22B	240328401	- B -	Bearing-hinge(ref), natural, upper
27A	240396102	A B C	Retainer, tall bottle
37	240359203	A - -	Trim-handle, 30.13", black, lower
37	240359201	- B -	Trim-handle, 30.13", white, lower
48	241511701	A B C	Bin-door, ref
49	241505301	A B C	Bin-door, 2-liter
49A	241505501	A B C	Bin-door, gallon
50	241508401	A B C	Cover-magnet
70	241515801	A B C	Compartment-dairy, removable
72	240421701	A B -	Button-handle mtg, dovetail
73	218396700	A B -	Block-handle mtg, dovetail
74	215503200	A B C	Screw, cr pan hd, 10-16 x 0.500
79	218755402	- - C	Screw-set, 10-32 x 0.375
80	218755503	- - C	Screw-shoulder, #10 AB, handle mounting

CABINET

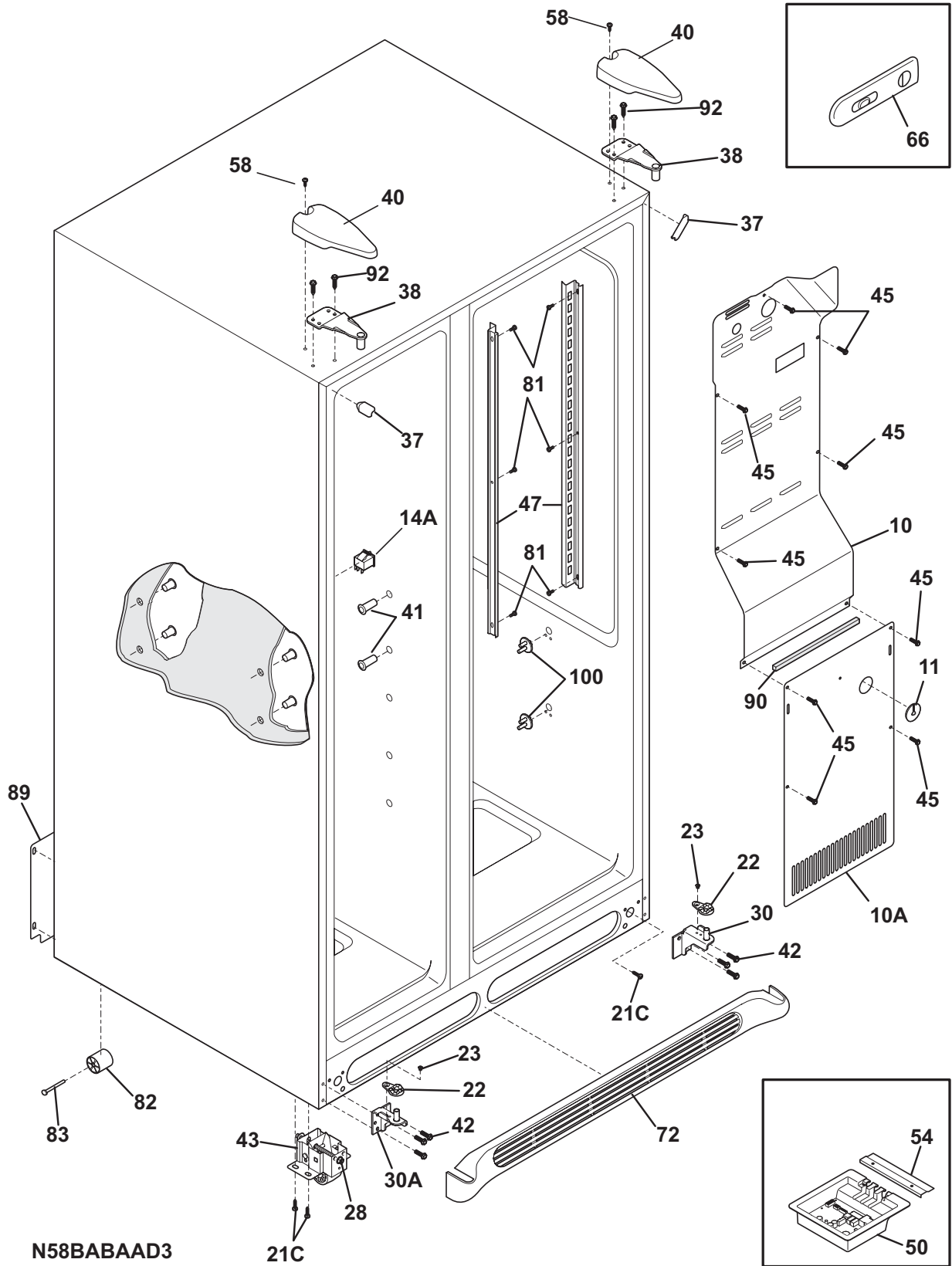

CABINET

Model Index: A FSC23F7D (FSC23F7DB4)
 B FSC23F7D (FSC23F7DW4)
 C FSC23F7DS (FSC23F7DSB6)

POS. NO	PART NO.		DESCRIPTION
10	241509802	A B C	Cover-air duct
10A	240475907	A B C	Cover-evap coil, lower
11	5303208309	A B C	Plug-hole, factory test
14A	241547901	A B C	Switch-light/lamp, frzr door
21C	218252200	A B C	Screw, #8 truss hd, 10-32CA x 0.500
22	240457702	A - C	Plate-door closer
22	240457701	- B -	Plate-door closer
23	240402701	A B C	Screw-#10-32 x 1/4 flat hd
28	240335501	A B C	Bolt-roller adj, hex washer head, 1/4-20 x 4.020, (2), special
30	241603701	A B C	Bracket-lower hinge, ref
30A	241603702	A B C	Bracket-lower hinge
37	240337603	A - C	Trim-cabinet corner, black, (2)
37	240337601	- B -	Trim-cabinet corner, white, (2)
38	240327201	A B C	Bracket-upper hinge
40	240327007	A - C	Cover-upper hinge, black
40	240327005	- B -	Cover-upper hinge, white
41	241550801	A B C	Grommet-shelf mtg, 1.40" long
41*	241550701	A B C	Grommet-shelf mtg, .96" long
42	240578901	A B C	Screw-hinge mtg, hex head, 1/4-20 x 5/8
43	240335003	A B C	Roller Assy, adjustable, front, (2)
45	241500301	A B C	Screw, hex washer head, 8-18AB x 0.500
47	241513001	A B C	Channel-shelf mtg, side, (2)
50	241511101	A B C	Board-main power
50*	241524801	A B C	Seal-Mother Board Housing
50*	241532501	A B C	Clip-harness
54	241532401	A B C	Channel
58	218781100	A B C	Screw, pan head, 8-18 x 0.625
66	241513601	A B C	Damper Assy
72	241521610	A - C	Grille/Kickplate, black
72	241521608	- B -	Grille/Kickplate, white
81	5308016566	A B C	Screw, hex washer head, 8-15A x 0.625, low profile
82	5304418225	A B C	Roller, compressor base, rear, (2)
83	5303316859	A B C	Rivet, flat head, 1/4 OD x 1-3/4, roller pin
89	241574602	A B C	Cover access
90	218249808	A B C	Seal-coil cover
92	216850900	A B C	Screw, hex washer hd, 1/4 x 7/8, hinge mtg
100	240423701	A B C	Support, crisper cover, front, (4)
100*	240350802	A B C	Support, crisper cover, rear, (4)
*	240479601	A B C	Plug, button, cab liner holes, (2)
*	241591701	A B C	Louver
*	5303321321	A - C	Paint, touch-up, black
*	5303321319	- B -	Paint, touch-up, white

SHELVES

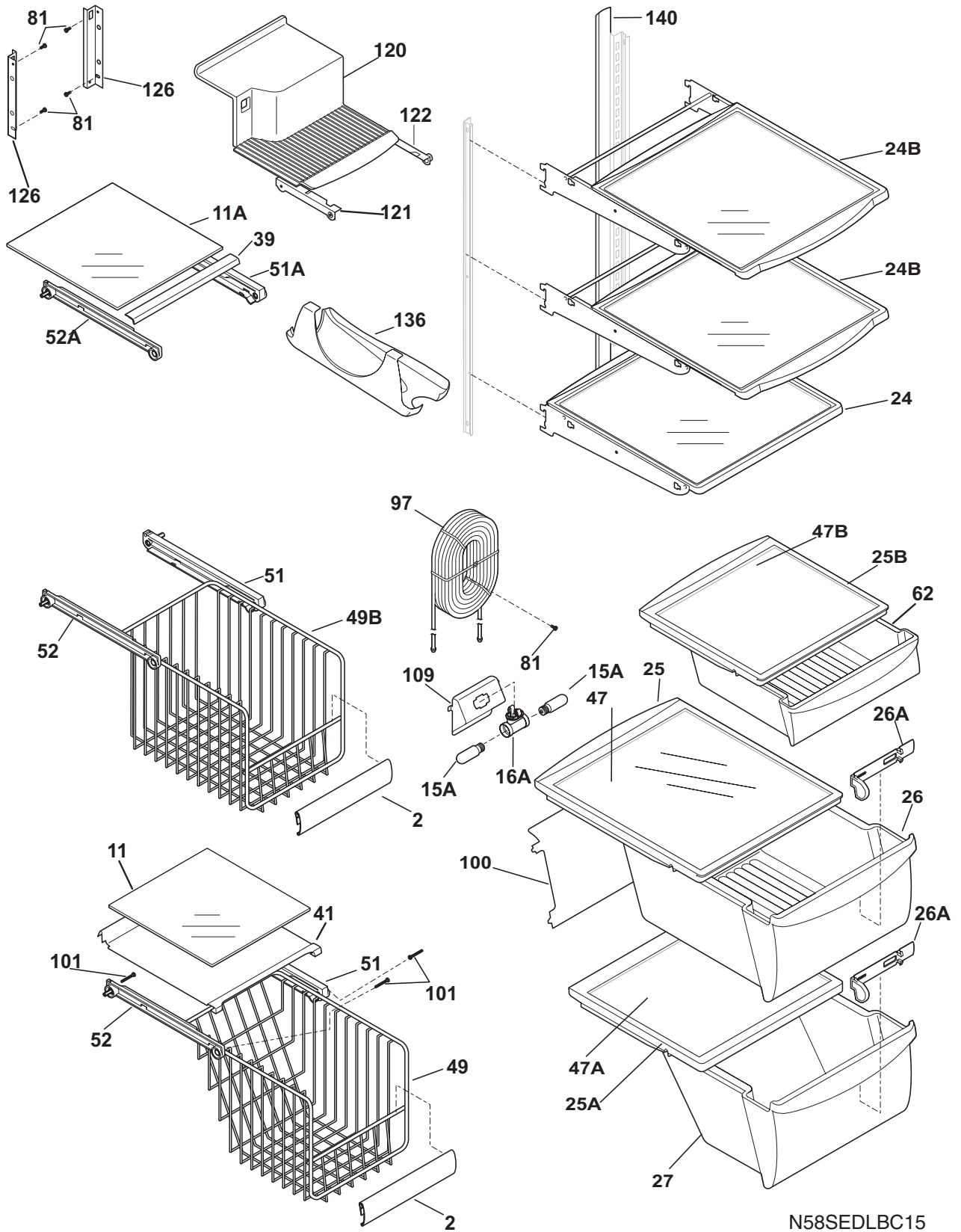

N58SEDLBC15

SHELVES

Model Index: A FSC23F7D (FSC23F7DB4)
 B FSC23F7D (FSC23F7DW4)
 C FSC23F7DS (FSC23F7DSB6)

POS. NO	PART NO.		DESCRIPTION
2	241510605	A B C	Trim-basket
11	240443357	A B C	Shelf-freezer, glass, lower
11A	240443358	A B C	Shelf-freezer, glass, upper
15A	241552801	A B C	Light Bulb
16A	241622802	A B C	Socket-light
16A*	241523201	A B C	Harness-wiring
24	240355240	A B C	Shelf-"Spill-Safe", fixed, (3)
24B	240350129	A B C	Shelf-"Spill-Safe", cantilever, sliding
25	240599301	A B C	Cover-crisper pan, upper
25*	240362101	A B C	Clip-slide, cover-crisper
25A	240350902	A B C	Cover-crisper pan, lower
25B	240599801	A B C	Cover-meat pan
26	240351005	A B C	Pan-crisper, upper
26*	240349801	A B C	Clip-slide, pan-crisper
26A	240362201	A B C	Control-humidity
27	240351205	A B C	Pan-crisper, lower
39	240367603	A B C	Trim-shelf, 11.65", front
41	241637601	A B C	Baffle-air
47	240350633	A B C	Insert-pan cover, glass
47A	240350603	A B C	Insert-pan cover, glass
47B	240443360	A B C	Insert-pan cover, glass
49	241515001	A B C	Basket-sliding
49B	241514901	A B C	Basket-sliding, upper, full
51	241514501	A B C	Hanger-basket, RH
51A	241514701	A B C	Hanger-shelf glass, RH
52	241514601	A B C	Hanger-basket, LH
52A	241514801	A B C	Hanger-shelf glass, LH
62	240599701	A B C	Pan-meat
81	5308016566	A B C	Screw, hex washer head, 8-15A x 0.625, low profile
97	241532002	A B C	Water Tank
100	241549901	A B C	Cover-water tank
101	218493100	A B C	Screw, hex washer head, 8-18AB x 1-3/4
109	241513202	A B C	Base-crisper light socket
120	241504501	A B C	Shelf-ice cream
121	241504701	A B C	Rail-ice cream shelf, LH
122	241504702	A B C	Rail-ice cream shelf, RH
126	241674401	A B C	Channel, auger mtg, LH
126	241674402	A B C	Channel, auger mtg, RH
136	240424502	A B C	Dispenser-can, clear
140	240430504	A B C	Channel, wtr tube cover

CONTROLS

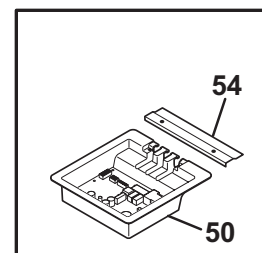
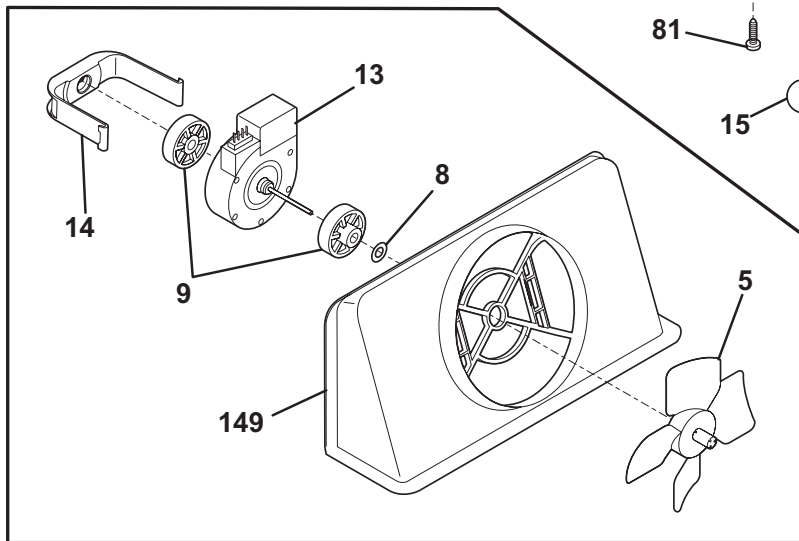
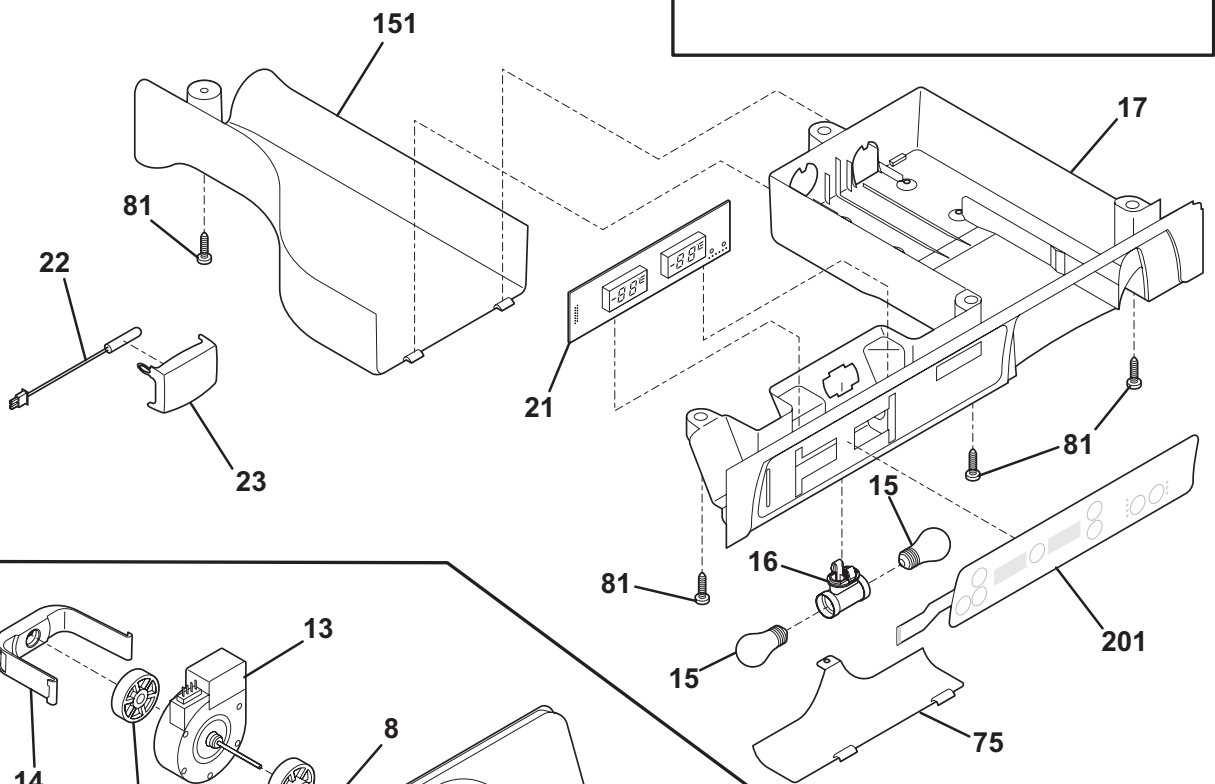
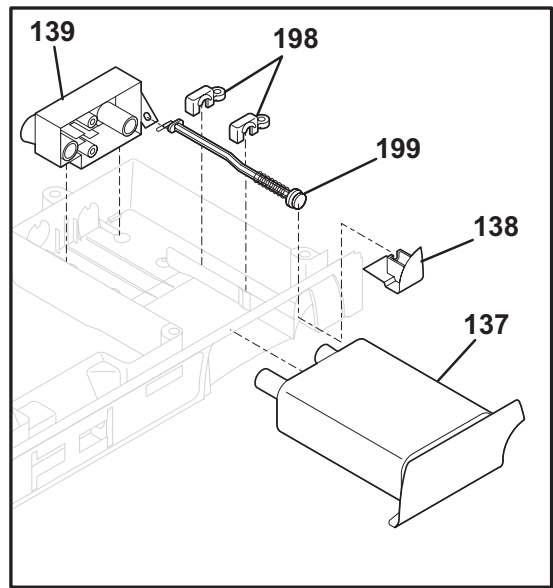
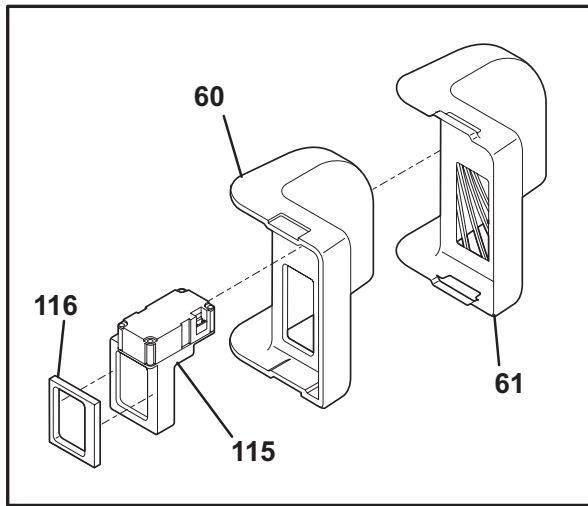

N58TBAAAB2

CONTROLS

Model Index: A FSC23F7D (FSC23F7DB4)
 B FSC23F7D (FSC23F7DW4)
 C FSC23F7DS (FSC23F7DSB6)

POS. NO	PART NO.		DESCRIPTION
5 #	5308000010	A B C	Fan Blade, red, evaporator fan
8	215474201	A B C	Washer, "slinger", nylon, evap fan shaft
9	241518301	A B C	Bushing, motor mounting
13	241509401	A B C	Motor, evaporator fan
13*	241510501	A B C	Seal-diffuser
14	241517701	A B C	Clip, evap fan motor
15	241552801	A B C	Light Bulb
16	241507803	A B C	Socket-light
17	241516201	A B C	Box-control, front
17*	241510801	A B C	Harness-wiring
21 #	240596701	A B C	Control, electronic
22	240597201	A B C	Sensor
23	241512901	A B C	Cover-sensor
50	241511101	A B C	Board-main power
50*	241524801	A B C	Seal-Mother Board Housing
54	241532401	A B C	Channel
60	241510401	A B C	Diffuser-air, top
61	241511201	A B C	Cover
75	241517801	A B C	Shield-light
81	241500301	A B C	Screw, hex washer head, 8-18AB x 0.500
115	241518501	A B C	Damper, motorized
116	241518601	A B C	Seal-damper, foam
137	240396401	A B C	Filter, water, carbon cassette, front, with o'rings
137*	240396701	A B C	Bypass, water filter, Optional Part
138	240397301	A B C	Button-filter release
139	240396002	A B C	Base-water filter
139*	240526901	A B C	O-ring, wtr filter base
149	241517601	A B C	Shroud-evap fan mtg
149*	241528304	A B C	Seal, foam, evap fan assy
151	241505001	A B C	Cover-water tube
198	240397401	A B C	Retainer
199	240397501	A B C	Rod
199*	240398401	A B C	Spring-filter release rod
201	241504102	A B C	Switch-membrane
*	3205266	A B C	Edge Protector, wiring harness

SYSTEM

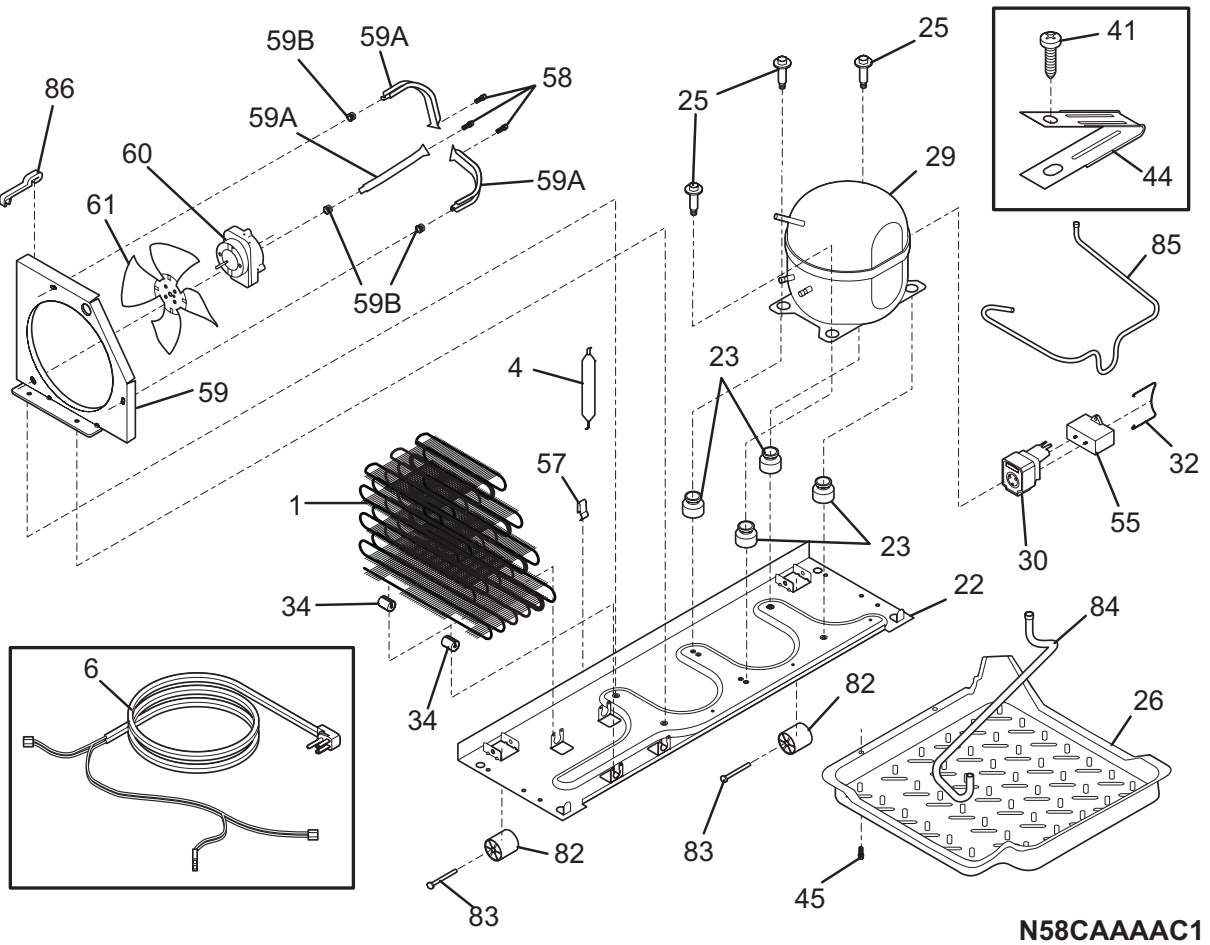
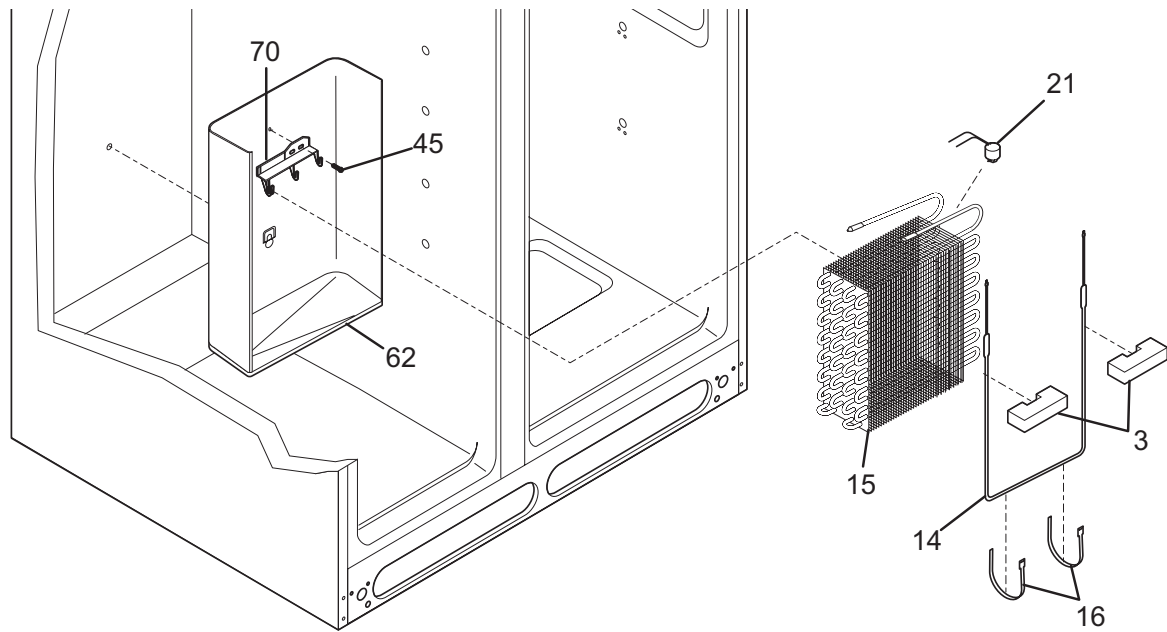

N58CAAAC1

SYSTEM

Model Index: A FSC23F7D (FSC23F7DB4)
 B FSC23F7D (FSC23F7DW4)
 C FSC23F7DS (FSC23F7DSB6)

POS. NO	PART NO.		DESCRIPTION
1	240333603	A B C	Condenser
3	218679607	A B C	Block-evap coil, styrofoam, (2)
4 #	218944001	A B C	Drier-filter, R134a System
6 #	241516901	A B C	Cord-service
6*	241510801	A B C	Harness-wiring
6*	241519901	A B C	Harness-wiring
6*	241635601	A B C	Harness-wiring, machine compt
14 #	240316107	A B C	Heater-defrost
15 #	5303918284	A B C	Evaporator Kit
16	5308000110	A B C	Strap-evap/heater, aluminum, (2)
21	5303918214	A B C	Thermostat-defrost, kit
22	240330008	A B C	Base-compressor mtg
22*	218252200	A B C	Screw, #8 truss hd, 10-32CA x 0.500
23	218513300	A B C	Grommet-compr mtg, (4)
25	240491501	A B C	Screw-compressor mtg, 1/4-28 x 1.16, shoulder, typ CF
26	241637301	A B C	Pan-defrost drain
29	5303918314	A B C	Compressor, w/o electricals
30	241527803	A B C	Starter-TSD
32	241544101	A B C	Clamp, elec cont mtg, compressor, bale wire
34	240405201	A B C	Grommet, rubber, black, cond tube/wire
41	240555001	A B C	Screw-#8-32 X 3/8
44	215174700	A B C	Clamp-service cord, strain relief, galv steel
45	5308016566	A B C	Screw, hex washer head, 8-15A x 0.625, low profile
55	218909915	A B C	Capacitor, run, 220 VAC, 15 microfarad
57	240542601	A B C	Clip-wiring harness
58	240433201	A B C	Screw, hex washer head, 8-18 x 0.375
59	240315502	A B C	Shroud-cond fan
59*	240346701	A B C	Tape-foam seal, shroud
59*	240359401	A B C	Screw-fan shroud, (2)
59A	240346501	A B C	Bracket-support, cond mtr, (3)
59B	240346601	A B C	Grommet-bracket, (3)
60 #	241584301	A B C	Motor-condenser fan
61	241639501	A B C	Blade-condenser fan
62	240429402	A B C	Trough-drain
70	218990801	A B C	Bracket-evap/cvr mtg
82	5304418225	A B C	Roller, compressor base, rear, (2)
83	5303316859	A B C	Rivet, flat head, 1/4 OD x 1-3/4, roller pin
84	5304421068	A B C	Tube-drain, lower
85	240553501	A B C	Tube-connector, suction
86	240409302	A B C	Spacer-cond tube, black
*	5303918327	A B C	Heat Exchanger Kit, suction line
*	5303918222	A B C	Hot Tube Repair Kit, service

ICE & WATER DISPENSER

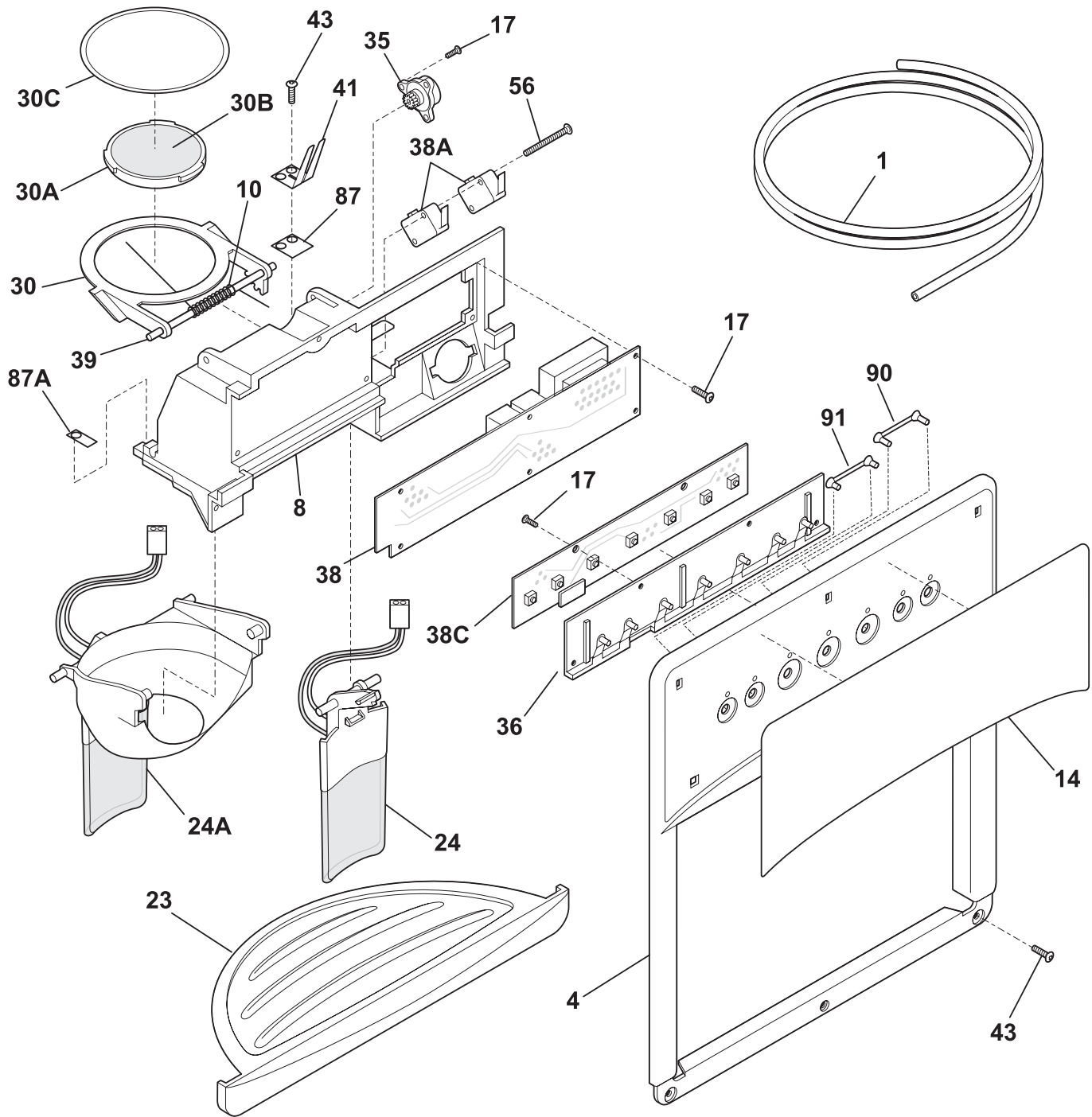

N58XEAAA0

ICE & WATER DISPENSER

Model Index: A FSC23F7D (FSC23F7DB4)
 B FSC23F7D (FSC23F7DW4)
 C FSC23F7DS (FSC23F7DSB6)

POS. NO	PART NO.		DESCRIPTION
1	218976409	A B C	Tube-water-DOOR
1*	218976901	A B C	Tube-water inlet, inlet valve, to ice maker
1*	218976903	A B C	Tube-water inlet, inlet valve, to filter
1*	218976912	A B C	Tube-water inlet, valve to door
1*	240561701	A B C	Seal-water inlet, inlet valve, to ice maker
4	5304422012	A - C	Cover-module, black
4	5304421822	- B -	Cover-module, white
8	5304424549	A - C	Module-dispenser
8	5304421823	- B -	Module-dispenser, white
10	5304426649	A B C	Spring-torsion
14	240323957	A - C	Label-module cover, black
14	240323955	- B -	Label-module cover, white
17	5304421619	A B C	Screw
23	241649003	A - C	Drip Tray, black
23	241649001	- B -	Drip Tray, white
24	5304433613	A - C	Actuator-water, black
24	5304433615	- B -	Actuator-water, white
24A	5304433610	A - C	Actuator-ice, black
24A	5304433612	- B -	Actuator-ice, white
30	5304421628	A B C	Door Assy-ice chute
30A	5304421624	A B C	Door center
30B	5304421625	A B C	Insulation-door
30C	5304421629	A B C	Door seal
35	5304421620	A B C	Damper-rotary
36	5304421824	A B C	Carrier
38	5304433619	A B C	Board-power
38A#	5304421617	A B C	Switch-micro, single pole, double throw
38C	5304433818	A B C	Board-control
38C*	5304430811	A B C	Harness-ribbon cable
39	5304421627	A B C	Pin-hinge
41	5304421829	A B C	Spring-actuator
43	215296300	A B C	Screw, plask h/l, #6 x 3/8
56	5304421830	A B C	Screw-micro switch, pan head
87	5304421622	A B C	Bearing Plate
87A	5304421621	A B C	Bearing Plate
90	5304421831	A B C	Light Pipe, reflector
91	5304421850	A B C	Light Pipe, reflector, short
*	5304426535	A B C	Insulator-electrical
*	5303918256	A B C	Dispenser heater kit

ICE CONTAINER

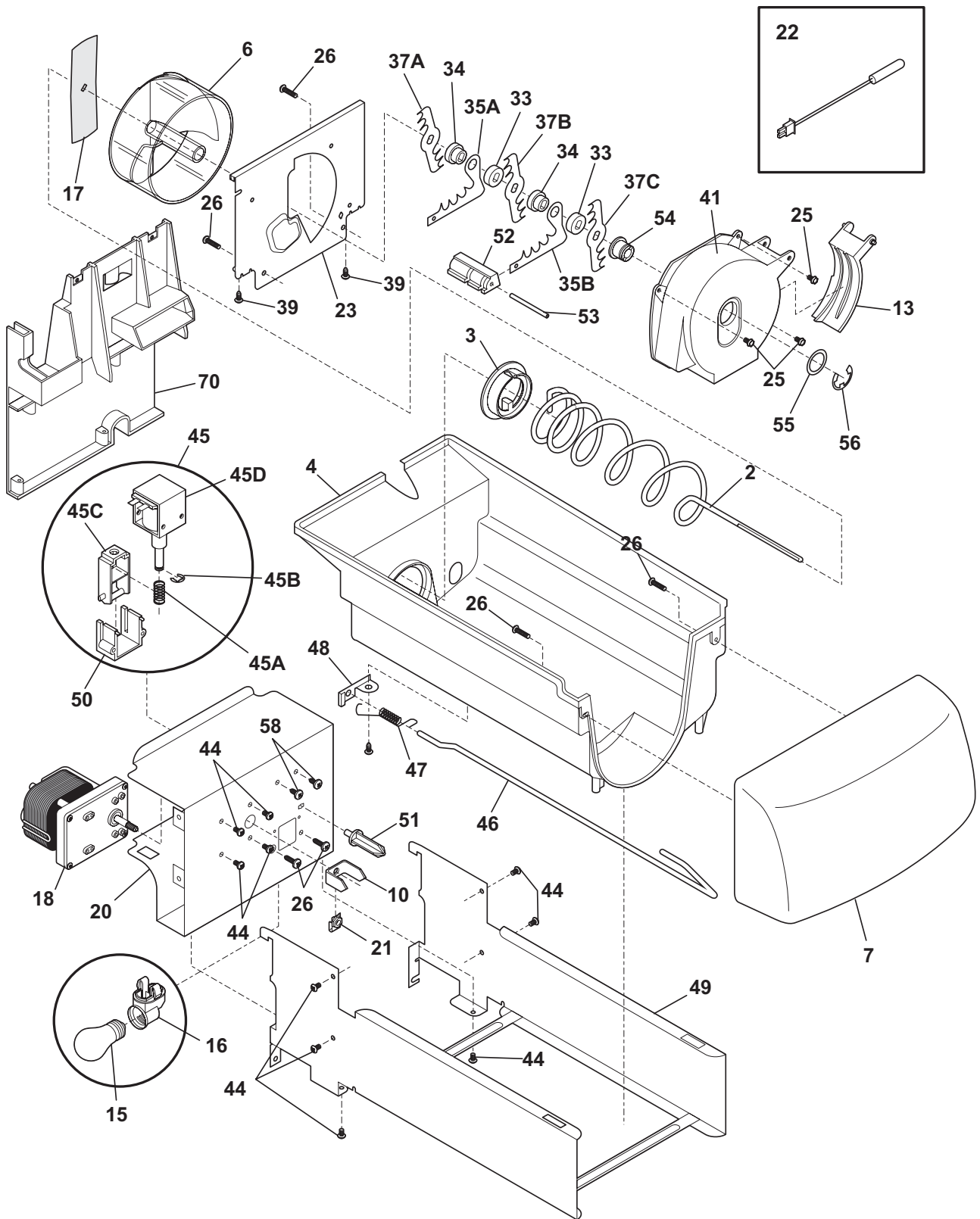

N58YDAAAC0

ICE CONTAINER

Model Index: A FSC23F7D (FSC23F7DB4)
 B FSC23F7D (FSC23F7DW4)
 C FSC23F7DS (FSC23F7DSB6)

POS. NO	PART NO.		DESCRIPTION
2	5304436634	A B C	Auger-ice
3	5304404343	A B C	Cam-drive
4	241515201	A B C	Container-ice, bucket only
6	5304404346	A B C	Drum-ice disp
7	241515301	A B C	Front-ice container
10	241624801	A B C	Bar-drive
13	5304404359	A B C	Gate
15	241555401	A B C	Light Bulb
16	241559801	A B C	Socket-light
17	5304404345	A B C	Drive Blade
18 #	5304440392	A B C	Motor-auger
18*	241522901	A B C	Harness-wiring, icmkr/container
20	5304404332	A B C	Cover-motor
21	215285100	A B C	Nut-drive
22	240597201	A B C	Sensor
22*	241519401	A B C	Clip, sensor
23	5304404347	A B C	Plate-front
25	5304404362	A B C	Screw, hex washer head, 8-32T x 0.375
26	215503200	A B C	Screw, cr pan hd, 10-16 x 0.500
33	5304404351	A B C	Spacer
34	5304404349	A B C	Spacer
35A	5304404353	A B C	Fixed Blade, round
35B	5304404352	A B C	Fixed Blade, square
37A	5304404348	A B C	Blade, crusher #1
37B	5304404350	A B C	Blade, crusher #2
37C	5304404356	A B C	Blade, crusher #3
39	5304404365	A B C	Screw
41	5304404358	A B C	Housing-crusher
44	218359200	A B C	Screw, pan head, 8-32 x 0.250
45 #	5304404333	A B C	Solenoid Assy
45A	5304406816	A B C	Spring-solenoid
45B	5304406817	A B C	E-Ring-solenoid
45C	5304406818	A B C	Actuator-solenoid
45D	5304406819	A B C	Solenoid
46	5304436635	A B C	Control Rod
47	5304404342	A B C	Spring-control rod
48	5304404340	A B C	Bracket-control rod
48*	5304404364	A B C	Screw-bracket
49	5304436702	A B C	Rail Assy
50	5304404334	A B C	Guide-solenoid
51	5304404336	A B C	Rotation Stop
52	5304404354	A B C	Spacer-fixed blades
53	5304404355	A B C	Pin-spiral, fixed blades
54	5304404357	A B C	Nut-auger
55	5304404360	A B C	Washer
56	5304404361	A B C	E-ring
70	241504601	A B C	Plate-mounting
70*	215005100	A B C	Screw, hanger/rlr mtg, 8-10 x 0.438
70*	241551601	A B C	Screw, hex head, 8-18B x 0.875
*	240562101	A B C	Insulator
*	241504301	A B C	Ice Container Assy, w/moving parts

ICE MAKER

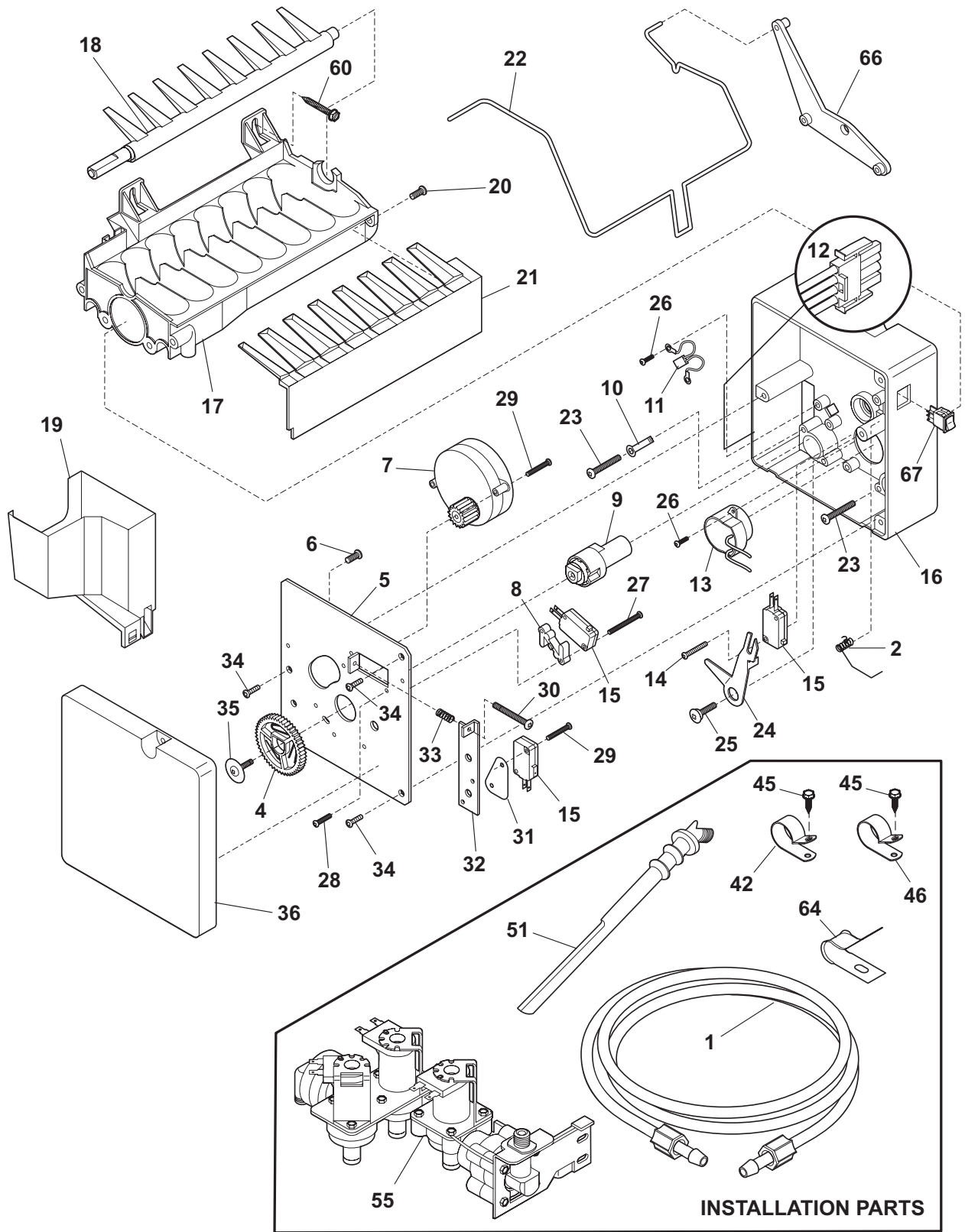

N58I115T

ICE MAKER

Model Index: A FSC23F7D (FSC23F7DB4)
 B FSC23F7D (FSC23F7DW4)
 C FSC23F7DS (FSC23F7DSB6)

POS. NO	PART NO.		DESCRIPTION
1	218976409	A B C	Tube-water-DOOR
1*	218976901	A B C	Tube-water inlet, inlet valve, to ice maker
1*	218976903	A B C	Tube-water inlet, inlet valve, to filter
1*	218976912	A B C	Tube-water inlet, valve to door
1*	240561701	A B C	Seal-water inlet, inlet valve, to ice maker
2	5304436616	A B C	Spring, torsion
4	3206301	A B C	Gear
5	5304436604	A B C	Plate-mounting
6	3206305	A B C	Screw-ground wire, 8-32 x 0.250
7 #	5304436619	A B C	Motor-ice maker
8	3206312	A B C	Spacer-hold switch
9	5304436610	A B C	Detent
10	3206315	A B C	Clamp
11 #	5304436618	A B C	Thermal Cutoff, ICE MAKER, complete assy
12	5304436614	A B C	Harness-wiring
13	5304436613	A B C	Thermostat, ICE MAKER
14	5304420652	A B C	Screw, 4 x 0.750, switch mtg.
15 #	3206324	A B C	Switch, (3)
16	5304436609	A B C	Housing, control
17 #	5304436617	A B C	Mold-ice maker, with heater
18	5304436607	A B C	Ejector-ice
18*#	240352601	A B C	Wiring Harness, internal, with plug
19	5304436606	A B C	Cup-water inlet
20	5304408581	A B C	Screw, 8-32 x 0.375
21	5304436608	A B C	Ice Stripper
22	5304436602	A B C	Shut-off Arm
23	5304408582	A B C	Screw, 8-32 x 0.875, mold-to-support, (3)
24	3206335	A B C	Lever Arm
25	5304404362	A B C	Screw, hex washer head, 8-32T x 0.375
26	5304420654	A B C	Screw-thermo/sprt, 4-24 x 0.375, (4)
27	3206338	A B C	Screw, 4-40 x 1.000, hold switch mtg, (2)
28	3206339	A B C	Screw-timing stop, 4-40 x 0.375
29	3206323	A B C	Screw, 4-24 x 0.750, (6)
30	3206341	A B C	Screw-timing adj, 8-32 x 1.000
31	3206342	A B C	Insulator
32	3206343	A B C	Plate-valve switch
33	5304436615	A B C	Spring-thermostat
34	5304420655	A B C	Screw, plazscrew, 8-10, (3)
35	5304408585	A B C	Screw
36	5304436605	A B C	Cover-ice maker
42	5303001199	A B C	Clamp-wiring harness, strain relief, galv steel
42*	218515402	A B C	Clip, (2), tube mtg.
45	5308016566	A B C	Screw, hex washer head, 8-15A x 0.625, low profile
46	5303001193	A B C	Clamp, .50 ID, steel, water tube
51	241523502	A B C	Tube-water fill, extension
55 #	240531101	A B C	Valve-water, triple solenoid
55*	218709100	A B C	Screw, hex head, 10-32 x 0.500
55*	240363601	A B C	Screw-shoulder

ICE MAKER

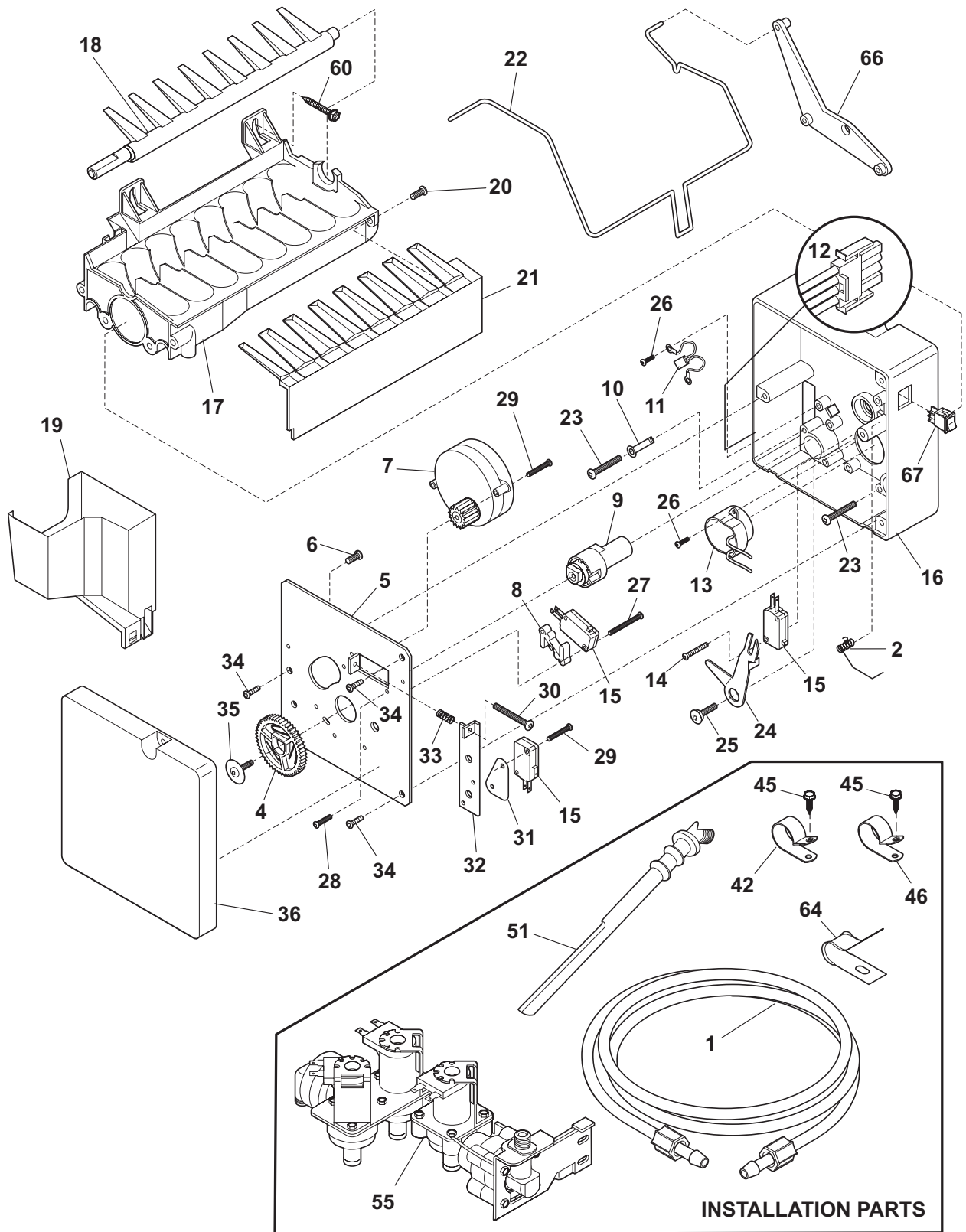

N58I115T

ICE MAKER

Model Index: **A** FSC23F7D (FSC23F7DB4)
 B FSC23F7D (FSC23F7DW4)
 C FSC23F7DS (FSC23F7DSB6)

POS. NO	PART NO.		DESCRIPTION
55*	240542901	A B C	Cap-water valve
60	5303001343	A B C	Screw, hex washer head, 8-15A x 0.500
64	5303001549	A B C	Clamp, 0.31 ID, steel, copper wtr line
66	5304436611	A B C	Bracket-ice maker
67	5304436612	A B C	Switch, on/off
*	218888001	A B C	Adapter-water supply, nut & sleeve, compression ftg
*	241583301	A B C	Deflector-air, ICE MAKER
* #	241696501	A B C	Ice Maker, Radius Cube, 115 V, no instl parts

WIRING SCHEMATIC

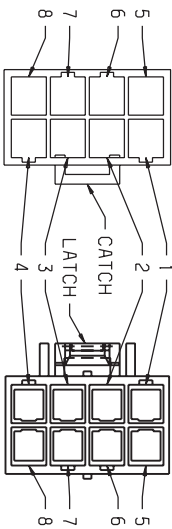
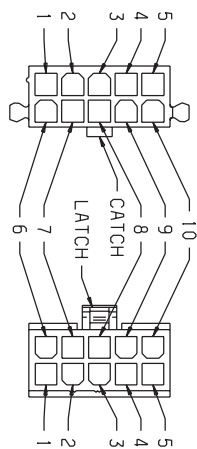
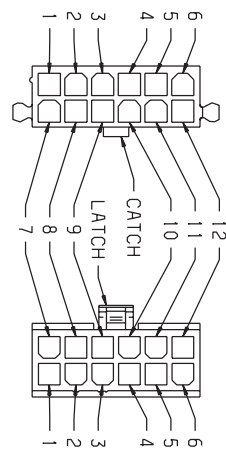
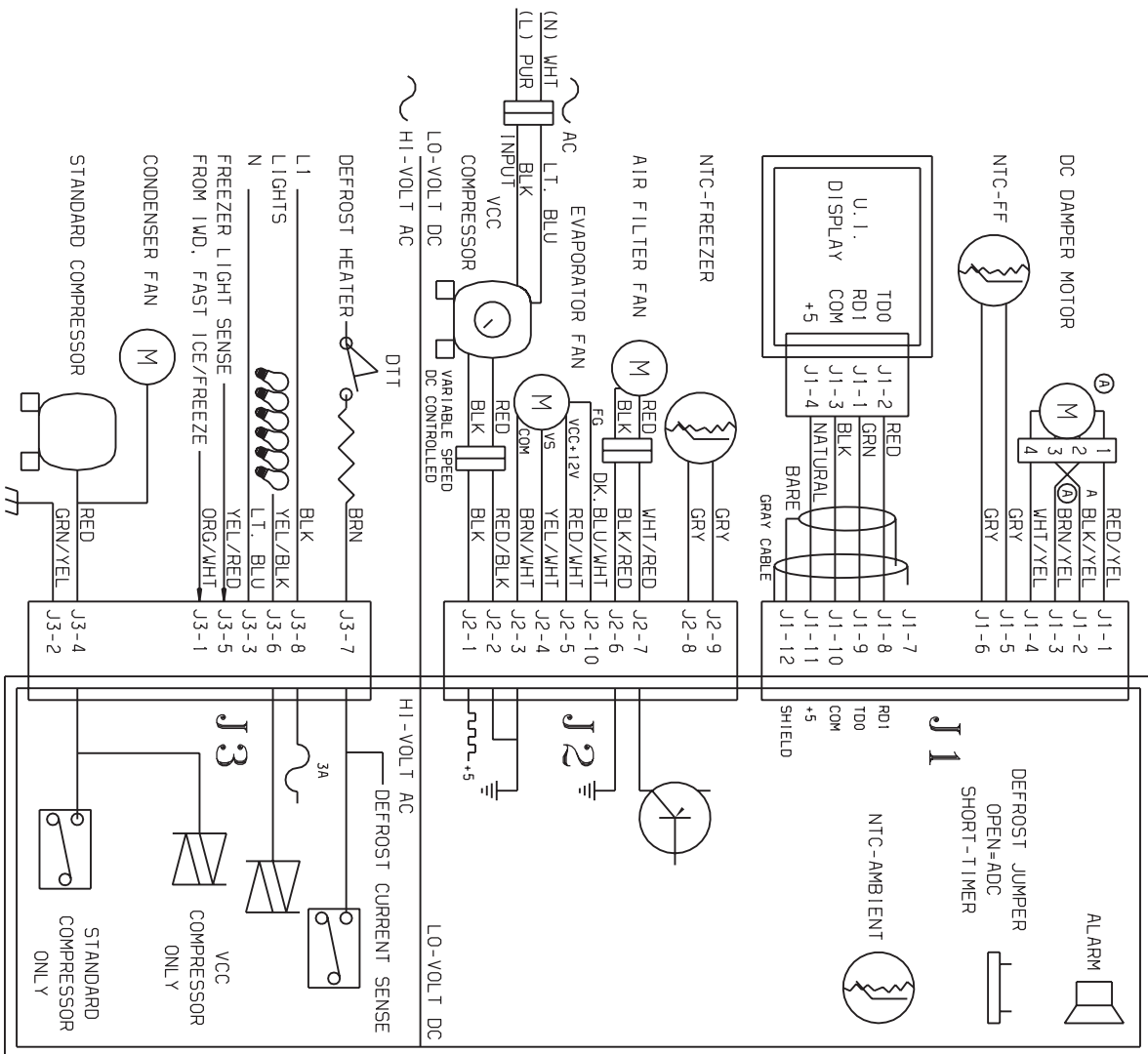

WIRING DIAGRAM

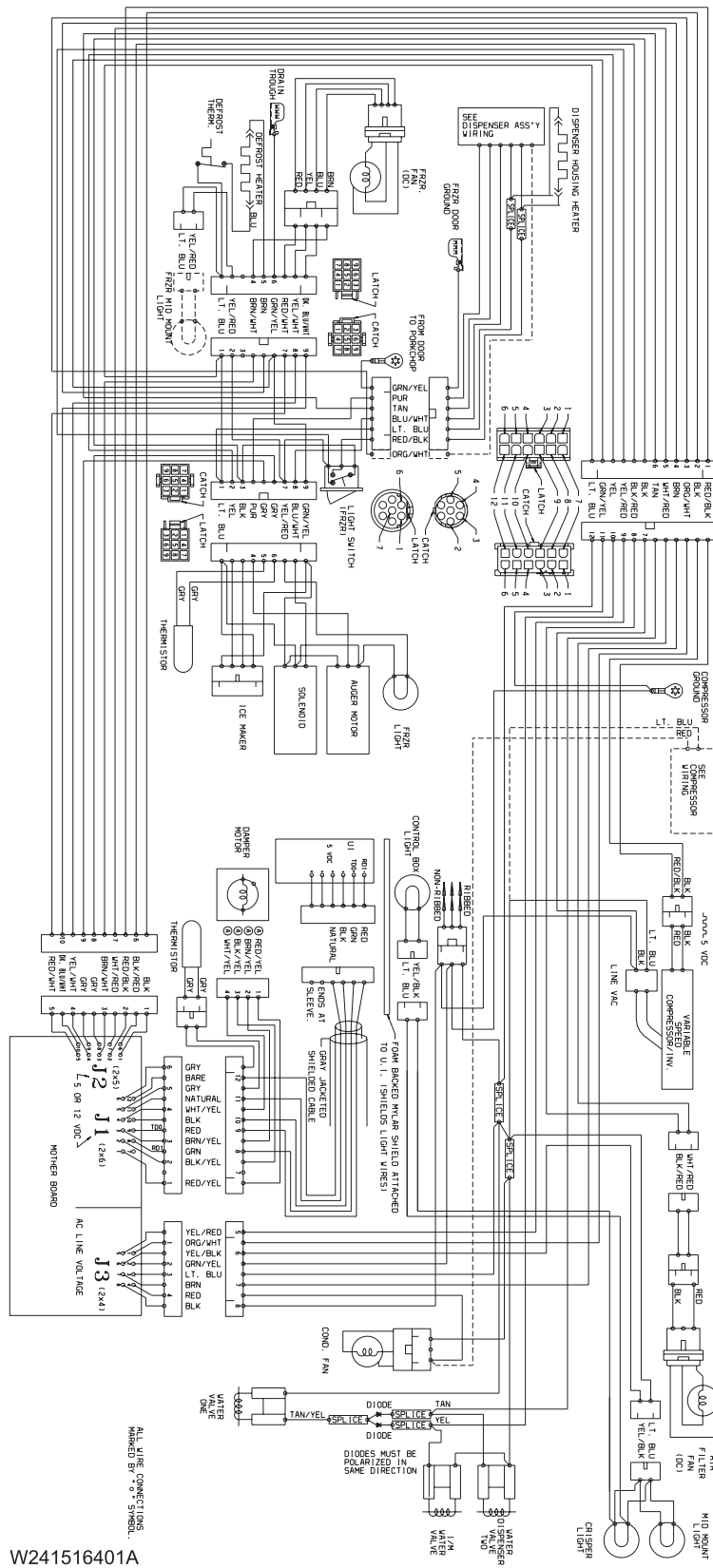

Functional Parts
* Non-Illustrated Parts